

LINEAR MODULES EUROPE TYPE 欧规模组

TPA 玖钧传动 · 智造兴邦



详细代理商资料查询TPA官网 Please check TPA official website for detailed agent information

华东制造基地: East China manufacturing base:

电话 Tel: 0512-50127418

地址: 江苏省昆山市高新区莱斯路15号

Address: No.15 Laisi Road, High-tech Zone, Kunshan City, Jiangsu Province

华南制造基地: South China manufacturing base:

电话 Tel: 0755-84644758

地址: 深圳市坪山区坑梓街道金沙社区东联工业区5号玖钧产业园

Address: Jiujun Industrial Park, No.5 Donglian Industrial Zone, Jinsha Community, Kengzi Street, Pingshan District, Shenzhen City

宁波制造基地: Ningbo manufacturing base

地址: 宁波市奉化区江口街道四明东路299号启迪工业园

Address: Tu Industrial Park, 299 Siming East Road, Jiangkou Street, Fenghua District, Ningbo City

上海分公司: Shanghai Branch

地址: 上海市松江区车墩镇北松公路5255号(智兆大厦)

Address: No.5255 Beisong Highway, Chedun Town, Songjiang District, Shanghai (Zhizhao Building)

北京办事处: Beijing office:

地址: 北京经济技术开发区科创十四街6号院1号楼

Address: Building 1, Yard 6, Kechuangshisi Street, Beijing Economic and Technological Development Zone

无锡办事处: Wuxi office:

地址: 无锡新吴区浩展大厦

Address: Haozhan Building, Xinwu District, Wuxi

浙江办事处: Zhejiang office:

地址: 浙江省绍兴市上虞区江扬路888号中富大厦

Address: Zhongfu Building, 888 Jiangyang Road, Shangyu District, Shaoxing City, Zhejiang Province, China

华中办事处: Central China office:

地址: 武汉市江夏区关南四路35号东港科技产业园

Address: Donggang Science and Technology Industrial Park, No.35 Guannansi Road, Jiangxia District, Wuhan City

东莞办事处: Dongguan office:

地址: 东莞市松山湖研发五路1号林润智谷6栋

Address: Building 6, Linrun Zhigu, No.1 R&D Fifth Road, Songshan Lake, Dongguan City

深圳办事处: Shenzhen office:

地址: 深圳市龙华区龙华街道龙观东路57号时代大厦

Address: Times building, No.57, Long Guan East rd, Longhua district, Shenzhen

版权所有 © 翻印必究 本型录内容如有变更, 恕不另行通知, 敬请谅解。 The contents of this catalogue are subject to change without prior notice.



TPA 网站
TPA website

微信公众号
Wechat public account



产品型录编号: TPA-BD-ZE-002

— 玖钧传动 · 智造兴邦 —

TPA 玖钧传动 Motion Control



— 玖钧传动 · 智造兴邦 —

目录 CONTENTS

■ 公司简介 company Intro

001

■ 半封闭皮带型 Semi-sealing Belt Driven Linear Actuator

007

TPA-ONB-60 ----- 011P/031P

TPA-ONB-80 ----- 015P/037P

TPA-ONB-100 ----- 019P/043P

TPA-ONB-120 ----- 023P/049P

TPA-ONB-140 ----- 027P/055P

TPA-ONB-80F ----- 061P

TPA-ONB-120F ----- 065P

■ 全封闭皮带型 Full-Sealing Belt Driven Linear Actuator

069

TPA-OCB-60 ----- 069P/093P

TPA-OCB-80 ----- 073P/099P

TPA-OCB-80S ----- 077P/105P

TPA-OCB-100 ----- 081P/111P

TPA-OCB-120 ----- 085P/117P

TPA-OCB-140 ----- 089P/123P

■ 参考资料 Reference data

129

公司简介

COMPANY INTRO ▶

TPA玖钧传动创立于2016年10月,隶属玖钧集团,总部坐落在中国·昆山,现有苏州、深圳、宁波三大研发中心、制造基地;全国拥有十几处服务据点。产品畅销海内外主要有:中国(台湾)、日本、越南、印度、美国、欧洲。总生产面积达45000余平方米,在职员工500人+,拥有各类先进设备近400台+。

注册商标TPA,寓意:TPA玖钧传动在摸索中“Transfer”不断改变,工作中“Passion”充满激情,发展中“Active”积极进取,永远以昂扬的斗志奋发向前。

TPA玖钧传动——专注于高速高精传动产品,是一家集专业研发、生产、销售、售后、服务为一体的国家级专精特新“小巨人”企业、国家高新技术企业、江苏省级专精特新、省级技术研发中心、江苏省民营科技企业、昆山市专精特新、智能控制SCARA机器人工程技术研究中心。主要产品有:精密传动部件(精密滚珠丝杆副、精密直线导轨副)、精密直线模组(日规模组、欧规模组、电动缸、钢基模组、内嵌式铝基模组、简易模组、直线电机、直驱旋转电机)、气浮运动控制平台系统、磁悬浮智能传输系统(磁驱环形线、磁悬浮传输系统)。

TPA玖钧传动产品主要服务于:汽车、激光、光伏、3C、锂电、医疗、集成电路、半导体、数控机床、储能、军工等11大产业及其他非标自动化设备;被广泛应用于取放、搬运、定位、分类、扫描、检测、点胶、焊锡等各类作业形式,模块化的产品满足客户多元化的应用场景。

TPA玖钧传动将秉承“永远为伙伴提供优质的服务,有责方远,利他共赢”的公司使命,优化产品,不断创新,始终坚持以高效的运作,优质的产品,精益求精的精神服务客户。

TPA玖钧传动以技术为核心、产品为基础、市场为导向、出色的服务团队、打造“TPA玖钧传动·智造兴邦”的行业新标杆。

TPA Motion Control was founded in October 2016 and is affiliated to JiuJun Group, Our headquarters is located in Kunshan, China. We have 3 R&D centers and manufacturing bases in Suzhou, Shenzhen and Ningbo, and have more than a dozen service locations across the world. Our products sell well at china and abroad mainly in: China (Taiwan), Taiwan(China), Japan, Vintem, India, USA, Europe. Our production area reaches more than 45,000 square meters, with 500+ employees and nearly 400+ sets of various advanced equipment.

Our registered trademark TPA means: TPA Robot "Transfer" continues to make progress in the process of exploration, "Passion" is full of passion in work, "Active" is proactive in development, and we always strives to move forward with high morale.

TPA Robot focuses on high-speed and high-precision transmission products. We are a national-level specialized and new "LITTLE GIANT" enterprise integrating professional R&D, production, sales, after-sales and service. Our main products include: precision transmission components (precision ball screws, precision linear guideways), linear modules (Ball screws driven linear modules, belt driven linear modules, rack & pinion linear modules, linear motors), air-floating motion control systems, magnetic drive intelligent transmission systems (magnetic drive ring lines, magnetic levitation transmission

TPA Robots products mainly serve industries such as automobiles, lasers, photovoltaics, 3C, lithium batteries, medical care, integrated circuits, semiconductors, CNC machine tools, energy storage, military industry and other non-standard automation equipment; they are widely used in pick and place, handling, positioning, classification, scanning, detection, dispensing, soldering and other types of operations, modular products meet customers' diverse application scenarios.

TPA Robot will adhere to the company mission of "always providing high-quality services to partners, being responsible, altruistic and win-win", optimizing products, constantly innovating, and always insisting on serving customers with efficient operations, high-quality products, and the spirit of excellence.

TPA Robot takes technology as the point, product as the foundation, market as the guide, and excellent service team to create a new industry benchmark of "TPA Robot · Intelligent Manufacturing to Prosper the Nation".



>> 公司价值观 Corporate values

核心的竞争和公司的价值观是企业品牌价值的重要体现。
The core competition and the company's values are the important embodiment of enterprise brand value.



出色的营销团队, 专业的产品咨询, 悉心的客户服务, 完善的售后体系。
Excellent marketing team, professional product consultation, attentive customer service and perfect after-sales system.

正直, 尊重个人。 任何讨论都以改善工作为前提。尊重差异, 保护多样式的个性。
Integrity and respect for individuals. Any discussion is premised on improving the work. Respect differences and protect multi-style personalities.

敬业, 客户至上。 为客户提供无可挑剔的服务。公司在做任何事情或任何决定时都必须同时考虑到客户的感受和利益。
Dedicated, customer first. Provide impeccable service to customers. The company must consider the feelings and interests of customers at the same time when doing anything or making any decision.

专业, 充满激情。 勤奋和敬业让我们出色, 投入让我们生动, 激情让我们卓越。
Professional and full of passion. Diligence and dedication make us outstanding, devotion makes us vivid, and passion makes us outstanding.

主动, 不断创新。 每个人都是推动公司前进的力量。我们崇尚个人主动创新。任何对公司有益的事情大家都会不遗余力的支持, 主动配合。我们相信每个人的努力都会对公司产生深远的影响。
Initiative and continuous innovation. Everyone is a force to push the company forward. We advocate individual initiative innovation. Everyone will spare no effort to support and actively cooperate with anything that is beneficial to the company. We believe that everyone's efforts will have a profound impact on the company.

我们的优势 Our advantage



- 1 平台优势 Platform advantage**
专业的传动组件制造厂商, 有苏州、深圳、宁波三大生产制造基地和研发中心, 拥有45000余平方米生产制造车间, 自有加工设备近400台+, 销售的产品都具有全自主知识产权。
Professional transmission component manufacturers, Suzhou, Shenzhen, Ningbo three major manufacturing bases and R & D center, with more than 45,000 square meters of production and manufacturing workshops, its own processing equipment
- 2 团队优势 Team advantage**
公司组织架构齐全, 团队核心成员均在行业耕耘十余年, 团队年轻化, 富有活力, 勇于担当, 可为客户提供准确的选型方案及其他相关咨询服务。
The company has a complete organizational structure, and the core members of the team have worked in the industry for more than ten years. The team is young, energetic and courageous, and can provide customers with accurate selection
- 3 技术优势 Technological advantage**
公司拥有百余位行业内资深技术研发人员, 可为客户提供非标定制化需求, 多样灵活的方案。
The company has more than 100 senior technical research and development personnel in the industry, can provide
- 4 产品优势 Product advantage**
核心配件自产, 自给率高, 立足于自动化设备传动领域, 产品类别齐全, 可满足客户在传动形式上多种需求。
Professional transmission component manufacturers, Suzhou, Shenzhen, Ningbo three major manufacturing bases and R & D center, with more than 45,000 square meters of production and manufacturing workshops, its own processing equipment
- 5 品质优势 Quality advantage**
拥有先进的制造设备、专业的检测设备, 完整的生产工艺流程、专业的团队, 多道品质检验流程, 确保产品一致性。
With advanced manufacturing equipment, professional testing equipment, complete production process, professional team, multi-channel quality inspection process to ensure product consistency.
- 6 服务优势 Service advantage**
我司拥有全球化销售网络, 办事处及专业的售后团队, 更快速响应客户售前、售中、售后服务需求。
Our company has a global sales network, offices and professional after-sales team, more quickly respond to customer pre-
- 7 社会责任 Social responsibility**
为员工提供舒适、安全、健康的工作环境, 精密传动配件自产自销, 打破进口依赖, 摆脱“卡脖子”障碍, 专注高速高精传动产品, 为国家智能制造发展添砖加瓦。
To provide employees with a comfortable, safe and healthy working environment, self-production and self-marketing of precision transmission parts, breaking the import dependence, getting rid of the "jam neck" barrier, focusing on high-speed
- 8 价格优势 Price advantage**
规模大、产能高、编制精、人员结构稳定;可帮助客户降低生产成本, 提高产品利润及市场竞争力。
Large scale, high production capacity, fine establishment, stable personnel structure; It can help customers reduce

TPA公司环境 Company Environment



TPA模组生产流程 Production process



1. 按照客户需求设计定制图纸。
Design customized drawings according to customer requirements.



2. 订单确认, 客户回传合同及图纸。
Order confirmation, Customers return contracts and drawings.



3. 按照图纸CNC生产加工。
CNC production and processing according to drawings

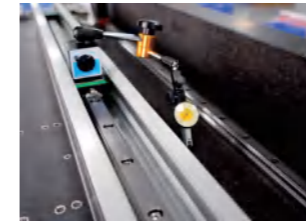

4. 检查底座平面度。
Check the flatness of the base.



5. 检查底座平行度。
Check the parallelism of the base.



6. 检查同步带张紧度。
Check the timing belt tension.



7. 检查有无卡顿情况。
Check for any stuck condition.



8. 通电测试重复定位精度。
Test the accuracy of repeated positioning by electrifying.

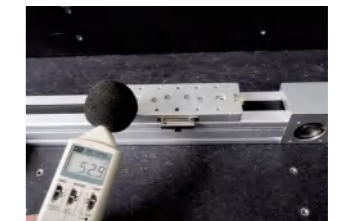

9. 模组运行噪音检测。
Running noise detection of module.

TPA
玖钧传动
Motion Control

线性模组出厂检验报告
LINEAR SLIDING TABLE FACTORY INSPECTION REPORT

产品名称: _____ 规格型号: _____
产品型号: _____ 订单号: _____

检验项目		检验结果		备注	
1	外观检查	合格			
2	尺寸精度	合格			
3	平行度	合格			
4	平面度	合格			
5	同步带张紧度	合格			
6	重复定位精度	合格			
7	运行噪音	合格			
8	其他				

玖钧传动·智造兴邦
www.tparobot.com

滑台出厂均附有相应检验报告, 确保产品符合使用要求, 方准予出厂。
The sliding table is shipped with the corresponding inspection report to ensure that the products meet the use requirements, and the sliding table is allowed to leave the factory.

滑台模组规格索引

Spec index of electric actuator

ONB半封闭皮带模组

ONB Semi-sealing Belt Driven Linear Actuator

使用环境 Environment	传动方式 Drive Method	规格 Specifications	减速机构 Reducer mechanism	马达容量 Motor output	本体宽度 Body Width(mm)	重复定位精度 Repeated positioning accuracy	皮带规格 Belt specification		最大可搬重量 Maximum Payload (kg)		最高速度 ^{*1} Maximum speed (mm/s)	标准行程建议最高使用速度 ^{*2} Stroke(mm) & Maximum speed (mm/s)															
							宽度 Belt width (mm)	导程 Lead (mm)	水平使用 Horizontal (kg)	垂直使用 Vertical (kg)		行程 Stroke 250 450 650 850 1050 1250 1450 1650 1850 2050 2250 2450 2650 2850 3050 3250 3450 3650 3850 4050 4250 4450 4650 4850 5050 5250 5450															
一般环境 General environment	同步带 Synchronous belt	TPA-ONB-60	无 NO	400W	65	±0.05	23	140	20	/	7000	3500															
		TPA-ONB-80		400W	80	±0.05	38	170	25	/	8500	4250															
		TPA-ONB-100	有 Yes	400W	100	±0.05	50	232	100	60	11600	3866															
		TPA-ONB-120		750W	120	±0.05	60	256	210	70	12800	4266															
		TPA-ONB-140		750W	140	±0.05	78	256	230	90	12800	4266															
		TPA-ONB-80F	无 NO	750W	80	±0.05	20	110	26	/	4500	2250															
		TPA-ONB-120F		750W	120	±0.05	30	90	32	/	4500	2250															

*1: 最高速度是以伺服马达最高转速3000RPM为基准。
The highest speed is based on the maximum servo motor's rpm(3000).
*2: 步进马达最高转速500RPM为基准。
The highest speed is based on the maximum stepping motor's rpm(500).
*3: 以上负载按照速度来划分。
The above loads are divided according to speed.

OCB全封闭皮带模组

OCB Full Seal Belt Driven Linear Actuator

使用环境 Environment	传动方式 Drive Method	规格 Specifications	减速机构 Reducer mechanism	马达容量 Motor output	本体宽度 Body Width(mm)	重复定位精度 Repeated positioning accuracy	皮带规格 Belt specification		最大可搬重量 Maximum Payload (kg)		最高速度 ^{*1} Maximum speed (mm/s)	标准行程建议最高使用速度 ^{*2} Stroke(mm) & Maximum speed (mm/s)															
							宽度 Belt width (mm)	导程 Lead (mm)	水平使用 Horizontal (kg)	垂直使用 Vertical (kg)		行程 Stroke 250 450 650 850 1050 1250 1450 1650 1850 2050 2250 2450 2650 2850 3050 3250 3450 3650 3850 4050 4250 4450 4650 4850 5050 5250 5450															
无尘环境 Clean room	同步带 Synchronous belt	TPA-OCB-60	无 NO	400W	65	±0.05	25	140	15	/	7000	3500															
		TPA-OCB-80		400W	80	±0.05	30	140	28	/	7000	3500															
		TPA-OCB-80S		400W	80	±0.05	30	140	22	/	5000	2500															
		TPA-OCB-100	有 Yes	750W	100	±0.05	50	192	90	50	9600	4800															
		TPA-OCB-120		750W	120	±0.05	50	224	200	60	11200	3700															
		TPA-OCB-140		750W	140	±0.05	60	256	220	80	12800	4200															

*1: 最高速度是以伺服马达最高转速3000RPM为基准。
The highest speed is based on the maximum servo motor's rpm(3000).
*2: 导程、最高速度会依减速比不同而异。
The lead and top speed will vary according to the reduction ratio.



半封闭皮带内部结构图说明

Description of internal structure diagram of Semi-Sealing Belt Driven Linear Actuator

全封闭皮带内部结构图说明

Description of internal structure diagram of Full-Sealing Belt Driven Linear Actuator

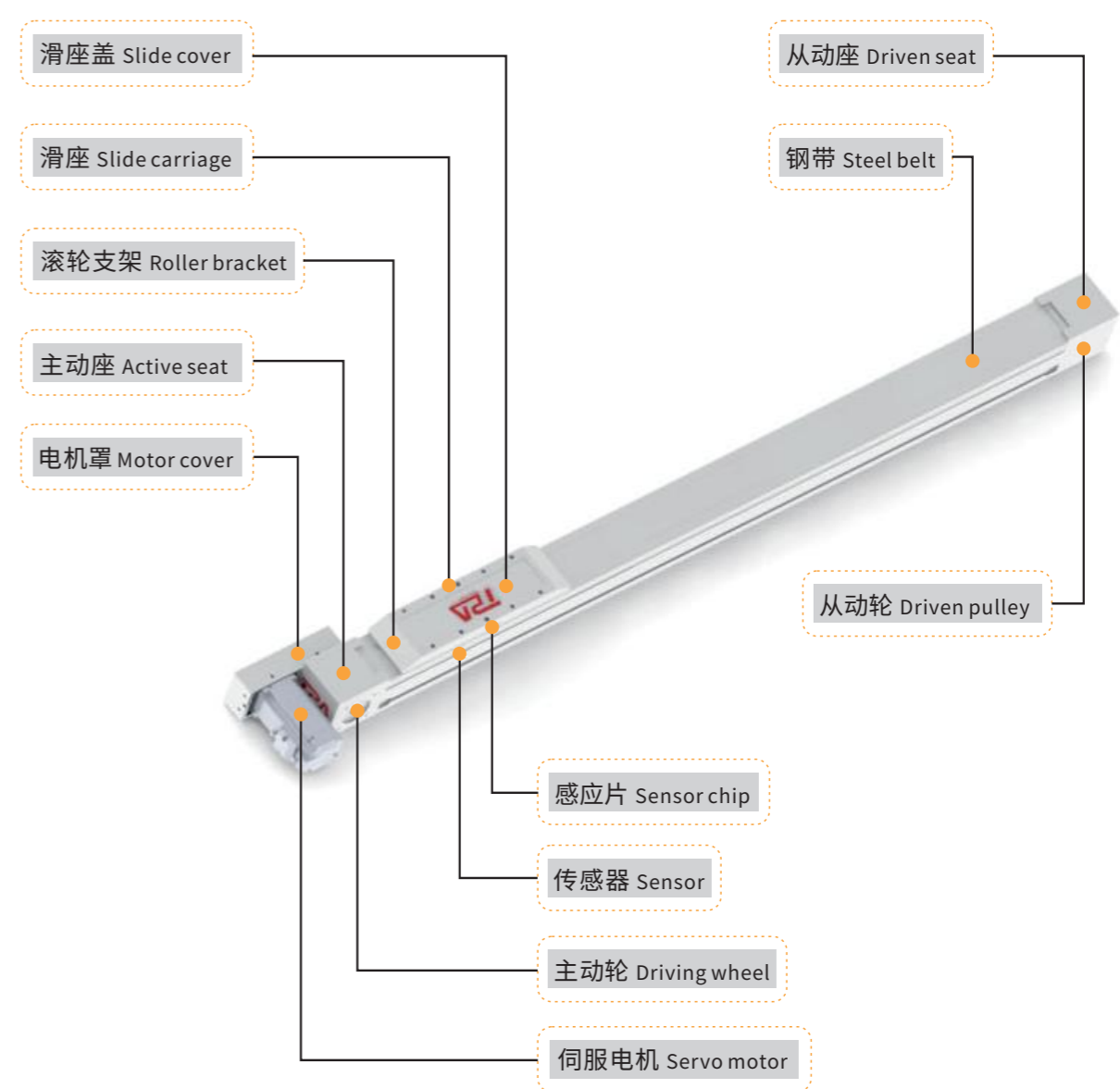
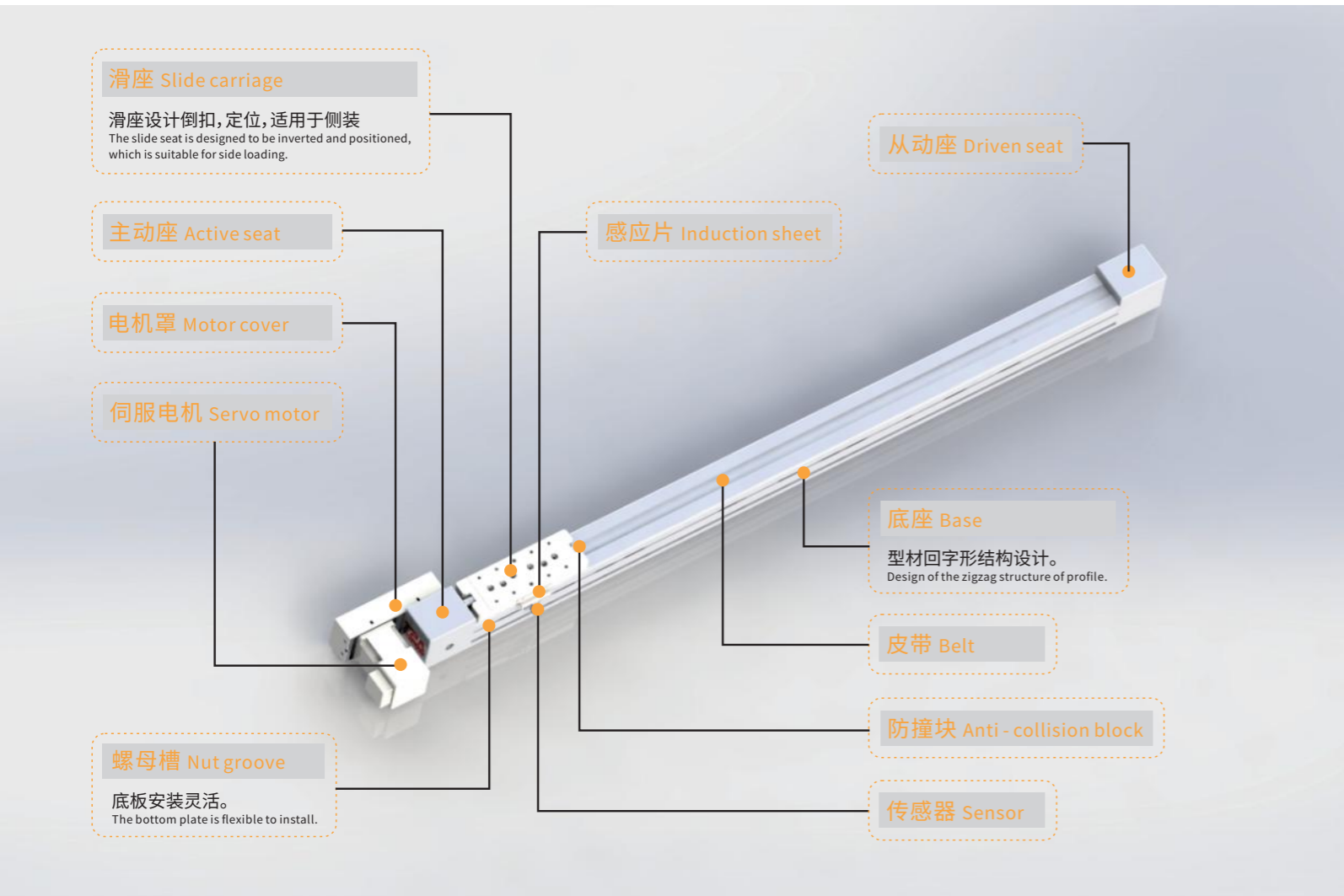



重复精度
Repeat Accuracy
±0.05
mm

此图仅供参考, 出货规格详见尺寸图面
This picture for reference only, specs details according with the drawing.

- 最大行程 Max Stroke: 3050mm
- 最高速度 Max Speed: 7000mm/s
- 马达容量 Motor Output: 400W
- 皮带宽度 Belt Width: 23mm
- 直线导轨 Linear Guide: 15X12.5-1支

型号表达方式 Ordering method

TPA-ONB-60-140-L3050-DL-Y-P40B-N3-F

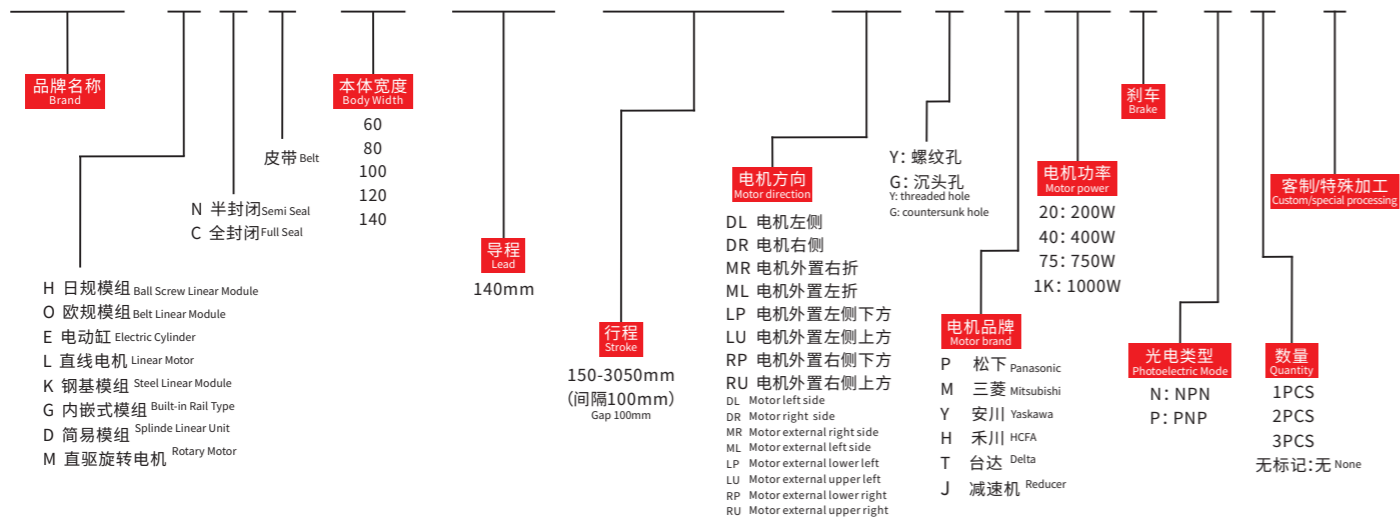

产品性能参数如下 Product performance parameters are as follows

规格 Spec	重复定位精度 (mm) Repeated positioning accuracy (mm)	±0.05					
	马达转速 (rpm/min) Rated Speed (rpm/min)	500	1000	1500	2000	2500	3000
部品 Parts	最高速度 (mm/s) Maximum speed (mm/s)	1160	2300	3500	5600	5800	7000
	最大可搬重量 (kg) Maximum Payload	水平使用 (kg) Horizontal (kg)					
	导程 (mm) lead (mm)	140					
	定格推力 (N) Rated thrust (N)	46					
	标准行程 (mm) Stroke pitch (mm)	150~3050mm/100 间隔 Gap 100mm					
	AC伺服马达容量 (W) AC servo motor output (w)	400					
皮带宽度 (mm) Belt Width (mm)	23						
高刚性直线导轨 (mm) High rigidity linear guide(mm)	15X12.5						
原点感应器 Home sensor	外挂 Outside	672(NPN)					

※1 马达加减速设定0.4秒。
※1 Acceleration and deceleration value is set 0.4 second.

容许负载力矩表 N.m Allowable overhang

有效行程 Stroke	150-950	150-1450	150-1950	2050-2450	2550-3050
数量 Quantity	6	8	10	12	16

※滑台标准固定方式为下锁式, 使用M5后装螺帽固定。
※Standard mounting method is fix from the bottom, using the M5 bolt and nut.

容许负载力矩表 N.m Allowable overhang



		水平安装 Horizontal installation			侧面安装 Side installation		
		线速度 Speed Maximum	A	B	线速度 Speed Maximum	A	B
导程 140 Lead	3kg	7000mm/s	-	-	3kg	7000mm/s	-
	6kg	5800mm/s	-	-	6kg	5800mm/s	-
	8kg	5600mm/s	-	-	8kg	5600mm/s	-
	10kg	3500mm/s	570	138	10kg	3500mm/s	10
	16kg	2300mm/s	335	67	16kg	2300mm/s	8
	20kg	1160mm/s	238	40	20kg	1160mm/s	8

搭配伺服马达一览表 Suitable motor brand

品牌 Brand	马达记号 Mark	刹车有无 Brake	马达容量 Motor capacity	电源电压 AC-Voltage	伺服马达型号 Servo motor model	驱动器型号 Driver Model
三菱 Mitsubishi	M	无刹车(水平式样) No brake (horizontal type)	400	220	HG-KR43	MR-J4-40A
松下 Panasonic	P	无刹车(水平式样) No brake (horizontal type)	400	220	MHMD042G1U	MBDHT2510
台达 Delta	T	无刹车(水平式样) No brake (horizontal type)	400	220	ECMA-C20604ES	ASD-B20421-B

速度-荷重曲线图 Acceleration-payload relationship

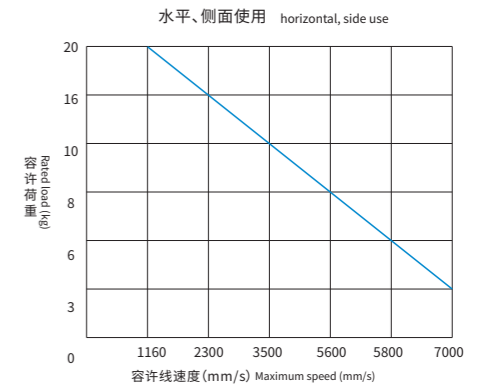

※以上使用条件请参考下方力矩表(最大值不可同时存在)。
※Please refer to the moment diagram below.(Do not reach all maximum value at same time.)

安装示意图 Installation diagram

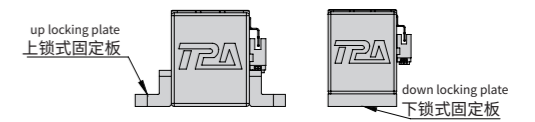

※上锁式固定板非标准品, 若有需求请另追加选购。
※Top fixing plate is optional.

静态容许负载惯量 Static loading moment

MY	MP	MR
46	46	10

※力矩表所表示的数据, 代表重心。
The torque value in the chart indicate the center of gravity.
※符合型录规范的正常试用下, 保证寿命为10000公里。
Operation life is 10,000km when the product is using under the specified conditions.
※侧吊使用无法套用标准规范, 如有需求请咨询我司业务。
The standard specification cannot be applied to the use of inverted crane.
Please consult our business if necessary.



电机左侧/电机右侧
Motor left side / Motor right side

DL 电机左侧 Motor left side

单位:Unit: mm

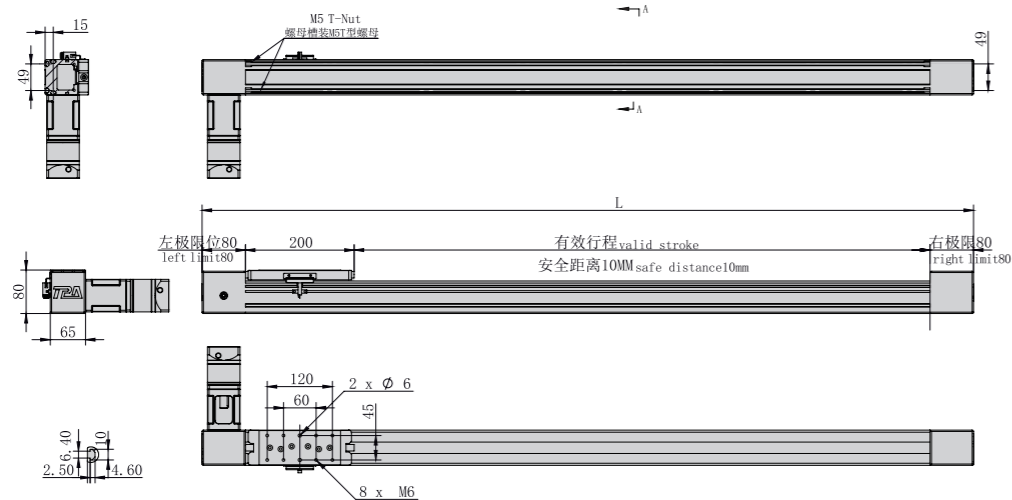

*不含电机和安装板重量 *Excluding motor and mounting plate weight

有效行程 Stroke	150	250	350	450	550	650	750	850	950	1050	1150	1250	1350	1450	1550
L	520	620	720	820	920	1020	1120	1220	1320	1420	1520	1620	1720	1820	1920
KG	5.1	5.6	6.1	6.6	7.1	7.6	8.1	8.6	9.1	9.6	10.1	10.6	11.1	11.6	12.1

有效行程 Stroke	1650	1750	1850	1950	2050	2150	2250	2350	2450	2550	2650	2750	2850	2950	3050
L	2020	2120	2220	2320	2420	2520	2620	2720	2820	2920	3020	3120	3220	3320	3420
KG	12.6	13.1	13.6	14.1	14.6	15.1	15.6	16.1	16.6	17.1	17.6	18.1	18.6	19.1	19.6

DR 电机右侧 Motor right side

单位:Unit: mm

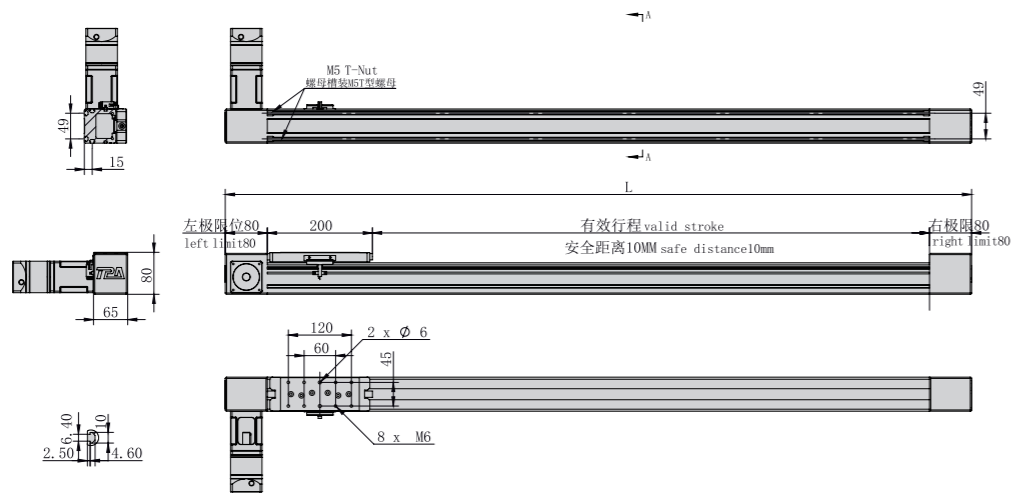

*不含电机和安装板重量 *Excluding motor and mounting plate weight

有效行程 Stroke	150	250	350	450	550	650	750	850	950	1050	1150	1250	1350	1450	1550
L	520	620	720	820	920	1020	1120	1220	1320	1420	1520	1620	1720	1820	1920
KG	5.1	5.6	6.1	6.6	7.1	7.6	8.1	8.6	9.1	9.6	10.1	10.6	11.1	11.6	12.1

有效行程 Stroke	1650	1750	1850	1950	2050	2150	2250	2350	2450	2550	2650	2750	2850	2950	3050
L	2020	2120	2220	2320	2420	2520	2620	2720	2820	2920	3020	3120	3220	3320	3420
KG	12.6	13.1	13.6	14.1	14.6	15.1	15.6	16.1	16.6	17.1	17.6	18.1	18.6	19.1	19.6

知识小课堂 Knowledge classroom

欧规模组特点 Feature of Belt Driven Linear Actuator

欧规模组是将伺服电机与同步带一体化设计的模块化产品,将伺服电机的旋转运动转换成直线运动,同时将伺服电机最佳优点-精确转速控制,精确转数控制,精确扭矩控制转变成-精确速度控制,精确位置控制,精确推力控制;实现高精度直线运动。

Belt driven linear actuator is a modular product that integrates servo motor and synchronous belt, which transforms the rotary motion of servo motor into linear motion, and at the same time transforms the best advantages of servo motor-precise speed control, precise revolution control and precise torque control into-precise speed control, precise position control and precise thrust control; And realize high-precision linear motion.

欧规模组创新特点 Innovative feature of Belt Driven Linear Actuator

创新特点一: Innovative feature 1:

型材设计运用有限元应力分析,运算模拟型材刚性,结构稳定性,不承载的面该薄的地方薄,厚的地方厚,降低型材本体重量,实际承载能力强,人性化设计。

The finite element stress analysis is used in the profile design to simulate the stiffness and structural stability of the profile. The non-bearing surface should be thin where it is thin and thick where it is thick, reducing the weight of the profile body, with strong actual bearing capacity and humanized design.

创新特点二: Innovative feature 2:

目前光伏和锂电行业大环境下,垂直和侧挂负载大的时候,不改变模组宽度和结构情况,在模组侧边安装一根辅轨,加强模组受到侧向力矩,还可以增加模组强度和模组运行稳定性。

At present, in the environment of photovoltaic and lithium battery industry, when the vertical and side hanging loads are large, the width and structure of the module are not changed, and an auxiliary rail is installed at the side of the module to strengthen the lateral moment of the module, which can also increase the strength and operational stability of the module.

创新特点三: Innovative feature 3:

半封闭、全封闭80宽度系列及以上,导轨选用高组,变动负荷设计,承载可变量力强。滑座长,接触面积大,同悬臂情况下,比普通低组模组晃动小,静音许力矩大。

Semi-enclosed, fully enclosed 80-width series and above, with high guide rail, variable load design and strong load-bearing capacity. The sliding seat is long, the contact area is large, and under the same cantilever condition, the shaking is smaller than that of the ordinary low-assembly module, and the static allowable torque is larger.

创新特点四: Innovative feature 4:

所有欧规半封闭模组,全封闭模组,滑座两侧都可以集中注油,不需要拆皮带和钢带,减少客户维护成本。

All European semi-closed actuator, fully closed actuator, and both sides of the sliding seat can be centrally oiled, and there is no need to disassemble the belt and steel belt, thus reducing the maintenance cost of customers.

创新特点五: Innovative feature 5:

皮带张紧设计采用双层保护,第一层张紧,第二层压板固定,防止欧规模组高速,超载情况下,皮带出现跳齿和皮带张紧块脱落。

The belt tensioning design adopts double-layer protection, the first layer is tensioned and the second laminated plate is fixed to prevent the belt from jumping teeth and the belt tensioning block from falling off under the condition of high speed and overload of Belt driven linear actuator.

创新特点六: Innovative feature 6:

欧规模组安装便捷,模组三个面设计滑块螺母槽,任意三面安装可选。客户不需要考虑安装空间,结构简化。

Belt driven linear actuator is easy to install, and three sides of the actuator are designed with slider nut grooves, and any three sides can be installed optionally. Customers do not need to consider the installation space, and the structure is simplified.

创新特点七: Innovative feature 7:

欧规半封闭模组,皮带宽度大与型材开口,一定程度上皮带替代盖板使用,防止异物进入模组里面。

The semi-closed belt drives the linear actuator, and the belt width is large and the profile is open. To some extent, the belt is used instead of the cover plate to prevent foreign objects from entering the module.

创新特点八: Innovative feature 8:

欧规模组电机安装方向,可以任意四个方向安装,轮子可以作为连轴器使用,减少客户横向空间,节约成本,加大拉电机的转矩,高效,高率。

The installation direction of European-scale group motor can be installed in any four directions, and the wheels can be used as couplings, which reduces the lateral space of customers, saves costs and increases the torque of the motor, with high efficiency and high rate.



重复精度
Repeat Accuracy
±0.05 mm

此图仅供参考, 出货规格详见尺寸图面
This picture for reference only, specs details according with the drawing.

- 最大行程 Max Stroke: 3050mm
- 最高速度 Max Speed: 8500mm/s
- 马达容量 Motor Output: 400W
- 皮带宽度 Belt Width: 38mm
- 直线导轨 Linear Guide: 20X17.5-1支

型号表达方式 Ordering method

TPA-ONB-80-170-L3050-DL-Y-P40B-N3-F

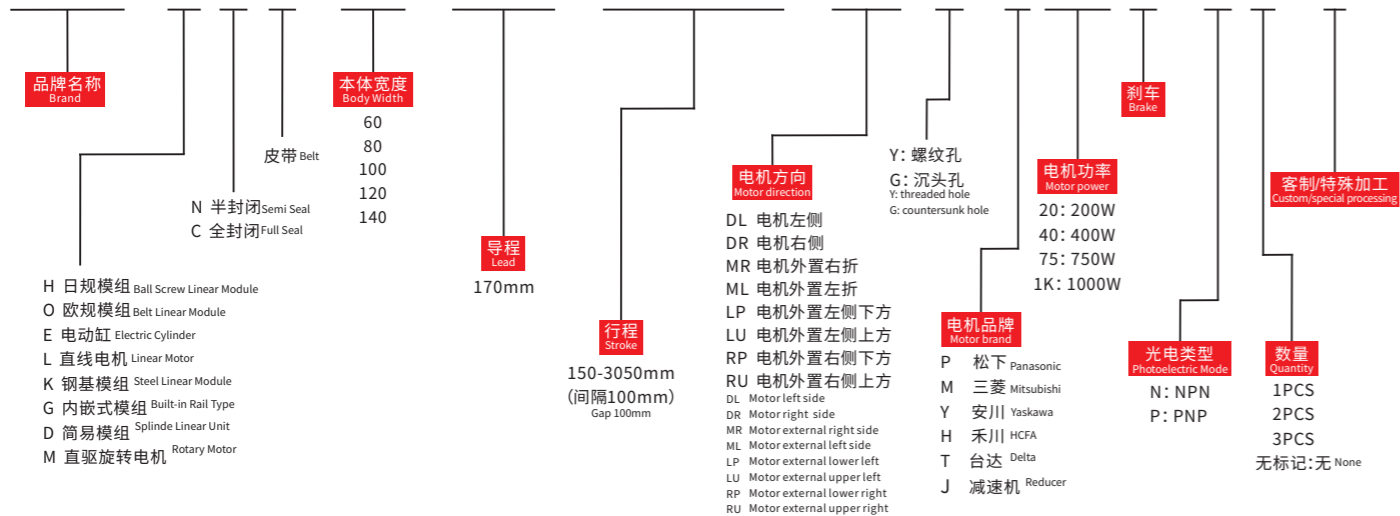

产品性能参数如下 Product performance parameters are as follows

规格 Spec	重复定位精度 (mm) Repeated positioning accuracy (mm)	±0.05					
	马达转速 (rpm/min) Rated Speed (rpm/min)	500	1000	1500	2000	2500	3000
	最高速度 (mm/s) Maximum speed (mm/s)	1400	2800	4300	5700	7100	8500
	最大可搬重量 Maximum Payload	水平使用 (kg) Horizontal (kg)					
部品 Parts	导程 (mm) lead (mm)	170					
	定格推力 (N) Rated thrust (N)	71					
	标准行程 (mm) Stroke pitch (mm)	150~3050mm/100 间隔 100 mm Pitch					
	AC伺服马达容量 (W) AC servo motor output (w)	400					
	皮带宽度 (mm) Belt Width (mm)	38					
	高刚性直线导轨 (mm) High rigidity linear guide(mm)	20X17.5					
原点感应器 Home sensor	外挂 Outside	672 (NPN)					

※1 马达加减速设定0.4秒。
※1 Acceleration and deceleration value is set 0.4 second.

容许负载力矩表 N.m Allowable overhang

有效行程 Stroke	150-950	150-1450	150-1950	2050-2450	2550-3050
数量 Quantity	6	8	10	12	16

※滑台标准固定方式为下锁式, 使用M5后装螺帽固定。
※Standard mounting method is fix from the bottom, using the M5 bolt and nut.

容许负载力矩表 N.m Allowable overhang



导程 170 Lead	水平安装 Horizontal installation (单位Unit:mm)					侧面安装 Side installation (单位Unit:mm)				
	重量 Weight	线速度 Speed Maximum	A	B	C	重量 Weight	线速度 Speed Maximum	A	B	C
170	2kg	8500mm/s	-	-	-	2kg	8500mm/s	-	-	-
	5kg	7100mm/s	-	-	-	5kg	7100mm/s	-	-	-
	6kg	5700mm/s	-	-	-	6kg	5700mm/s	-	-	-
	10kg	4300mm/s	300	60	80	10kg	4300mm/s	300	60	80
	18kg	2800mm/s	200	30	60	18kg	2800mm/s	200	30	60
	25kg	1400mm/s	100	10	30	25kg	1400mm/s	100	10	30

搭配伺服马达一览表 Suitable motor brand

品牌 Brand	马达记号 Mark	刹车有无 Brake	马达容量 Motor capacity	电源电压 AC-Voltage	伺服马达型号 Servo motor model	驱动器型号 Driver Model
三菱 Mitsubishi	M	无刹车(水平式样) No brake (horizontal type)	750	220	HG-KR73	MR-J4-70A
松下 Panasonic	P	无刹车(水平式样) No brake (horizontal type)	750	220	MHMD082G1U	MBDHT3520
台达 Delta	T	无刹车(水平式样) No brake (horizontal type)	750	220	ECMA-C20807ES	ASD-B20721-B

速度-荷重曲线图 Acceleration-payload relationship

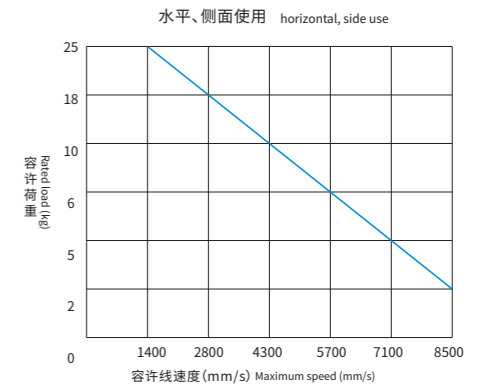

※以上使用条件请参考下方力矩表(最大值不可同时存在)。
※Please refer to the moment diagram below.(Do not reach all maximum value at same time.)

安装示意图 Installation diagram

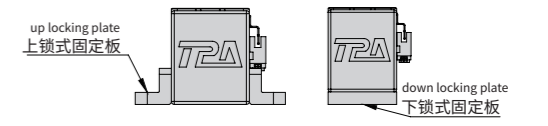

※上锁式固定板非标准品, 若有需求请另追加选购。
※Top fixing plate is optional.

静态容许负载惯量 Static loading moment

轴端位置 Axis End Position	静态容许负载惯量 Static loading moment (单位Unit:N.m)
MY	71
MP	71
MR	20

※力矩表所表示的数据, 代表重心。
The torque value in the chart indicate the center of gravity.
※符合型录规范的正常试用下, 保证寿命为10000公里。
Operation life is 10,000km when the product is using under the specified conditions.
※侧吊使用无法套用标准规范, 如有需求请咨询我司业务。
The standard specification cannot be applied to the use of inverted crane.
Please consult our business if necessary.



电机左侧/电机右侧
Motor left side / Motor right side

DL 电机左侧 Motor left side

单位:Unit: mm

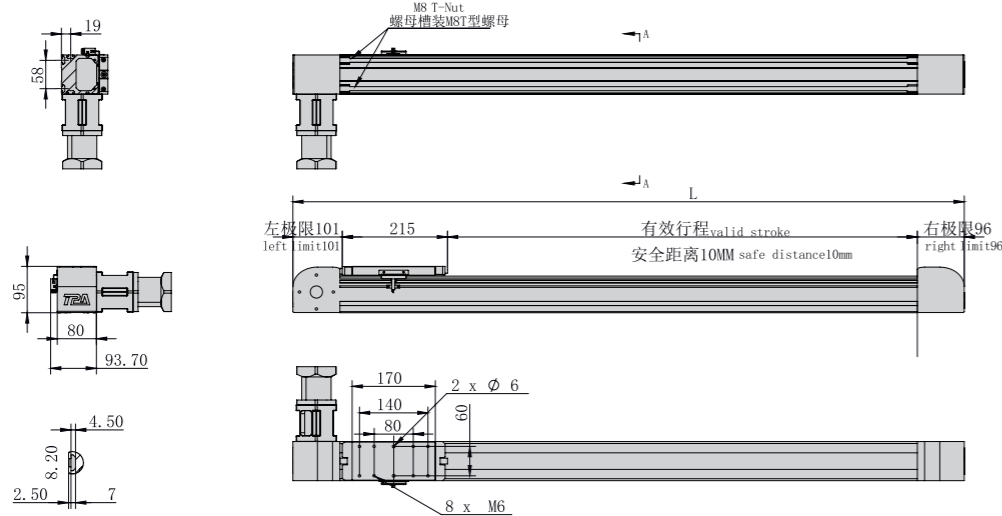

*不含电机和安装板重量 *Excluding motor and mounting plate weight

有效行程 Stroke	150	250	350	450	550	650	750	850	950	1050	1150	1250	1350	1450	1550
L	572	672	772	872	972	1072	1172	1272	1372	1472	1572	1672	1772	1872	1972
KG	11.4	12.1	12.8	13.5	14.2	14.9	15.6	16.3	17	17.7	18.4	19.1	19.8	20.5	21.2

有效行程 Stroke	1650	1750	1850	1950	2050	2150	2250	2350	2450	2550	2650	2750	2850	2950	3050
L	2072	2172	2272	2372	2472	2572	2672	2772	2872	2972	3072	3172	3272	3372	3472
KG	21.9	22.6	23.3	24	24.7	25.4	26.1	26.8	27.5	28.2	28.9	29.6	30.3	31	31.7

DR 电机右侧 Motor right side

单位:Unit: mm

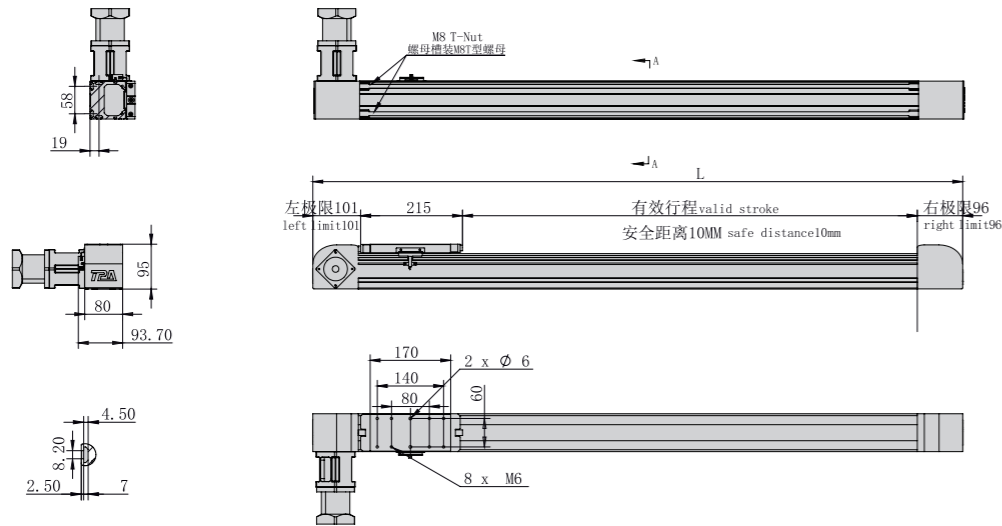

*不含电机和安装板重量 *Excluding motor and mounting plate weight

有效行程 Stroke	150	250	350	450	550	650	750	850	950	1050	1150	1250	1350	1450	1550
L	572	672	772	872	972	1072	1172	1272	1372	1472	1572	1672	1772	1872	1972
KG	11.4	12.1	12.8	13.5	14.2	14.9	15.6	16.3	17	17.7	18.4	19.1	19.8	20.5	21.2

有效行程 Stroke	1650	1750	1850	1950	2050	2150	2250	2350	2450	2550	2650	2750	2850	2950	3050
L	2072	2172	2272	2372	2472	2572	2672	2772	2872	2972	3072	3172	3272	3372	3472
KG	21.9	22.6	23.3	24	24.7	25.4	26.1	26.8	27.5	28.2	28.9	29.6	30.3	31	31.7

MEMO

ONB

OCB

参考资料
Reference
data



重复精度
Repeat Accuracy
±0.05 mm

此图仅供参考, 出货规格详见尺寸图面
This picture for reference only, specs details according with the drawing.

- 最大行程 Max Stroke: 3050mm
- 最高速度 Max Speed: 11600mm/s
- 马达容量 Motor Output: 750W
- 皮带宽度 Belt Width: 50mm
- 直线滑轨 Linear Guide: 25X22-1支

型号表达方式 Ordering method

TPA-ONB-100-232-L3050-DL-Y-P75B-N3-F

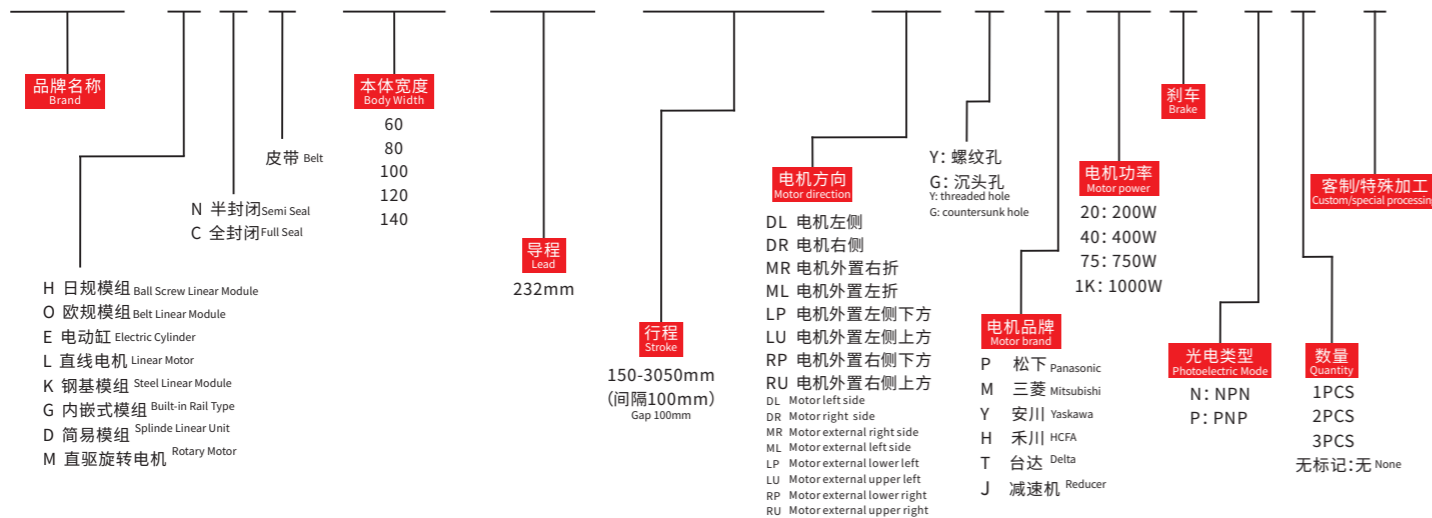

产品性能参数如下 Product performance parameters are as follows

规格 Spec	重复定位精度 (mm) Repeated positioning accuracy (mm)	±0.05					
	马达转速 (rpm/min) Rated Speed (rpm/min)	500	1000	1500	2000	2500	3000
部品 Parts	最高速度 (mm/s) Maximum speed (mm/s)	1900	3900	5800	7700	9700	11600
	最大可搬重量 Maximum Payload	水平使用 (kg) Horizontal (kg)					
	导程 (mm) lead (mm)	30	23	18	10	3	1
	定格推力 (N) Rated thrust (N)	51					
	标准行程 (mm) Stroke pitch (mm)	150~3050mm/100 间隔 100 mm Pitch					
	AC伺服马达容量 (W) AC servo motor output (w)	750					
皮带宽度 (mm) Belt Width (mm)	50						
高刚性直线滑轨 (mm) High rigidity linear guide(mm)	25X22						
原点感应器 Home sensor	外挂 Outside	672 (NPN)					

※1 马达加减速设定0.4秒。
※1 Acceleration and deceleration value is set 0.4 second.

容许负载力矩表 N.m Allowable overhang

有效行程 Stroke	150-950	150-1450	150-1950	2050-2450	2550-3050
数量 Quantity	6	8	10	12	14

※滑台标准固定方式为下锁式, 使用M5后装螺帽固定。
※Standard mounting method is fix from the bottom, using the M5 bolt and nut.

容许负载力矩表 N.m Allowable overhang



导程 Lead	水平安装 Horizontal installation (单位Unit:mm)					侧面安装 Side installation (单位Unit:mm)				
	重量 Weight	线速度 Speed Maximum	A	B	C	重量 Weight	线速度 Speed Maximum	A	B	C
232	1kg	11600mm/s	-	-	-	1kg	11600mm/s	-	-	-
	3kg	9700mm/s	-	-	-	3kg	9700mm/s	-	-	-
	10kg	7700mm/s	-	-	-	10kg	7700mm/s	-	-	-
	18kg	5800mm/s	-	-	-	18kg	5800mm/s	-	-	-
	23kg	3900mm/s	180	35	40	23kg	3900mm/s	180	35	40
	30kg	1900mm/s	100	20	30	30kg	1900mm/s	100	20	30

搭配伺服马达一览表 Suitable motor brand

品牌 Brand	马达记号 Mark	刹车有无 Brake	马达容量 Motor capacity	电源电压 AC-Voltage	伺服马达型号 Servo motor model	驱动器型号 Driver Model
三菱 Mitsubishi	M	无刹车(水平式样) No brake (horizontal type)	750	220	HG-KR73	MR-J4-70A
松下 Panasonic	P	无刹车(水平式样) No brake (horizontal type)	750	220	MHMD082G1U	MBDHT3520
台达 Delta	T	无刹车(水平式样) No brake (horizontal type)	750	220	ECMA-C20807ES	ASD-B20721-B

速度-荷重曲线图 Acceleration-payload relationship

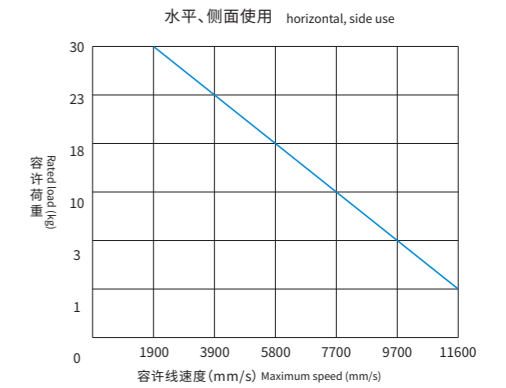

※以上使用条件请参考下方力矩表(最大值不可同时存在)。
※Please refer to the moment diagram below.(Do not reach all maximum value at same time.)

安装示意图 Installation diagram

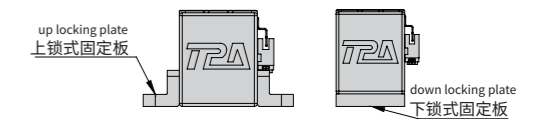

※上锁式固定板非标准品, 若有需求请另外追加选购。
※Top fixing plate is optional.

静态容许负载惯量 Static loading moment

配置 Configuration	静态容许负载惯量 Static loading moment (单位Unit:N.m)
MY	51
MP	51
MR	27

※力矩表所表示的数据, 代表重心。
The torque value in the chart indicate the center of gravity.
※符合型录规范的正常试用下, 保证寿命为10000公里。
Operation life is 10,000km when the product is using under the specified conditions.
※侧吊使用无法套用标准规范, 如有需求请咨询我司业务。
The standard specification cannot be applied to the use of inverted crane. Please consult our business if necessary.



电机左侧/电机右侧
Motor left side / Motor right side

DL 电机左侧 Motor left side

单位:Unit: mm

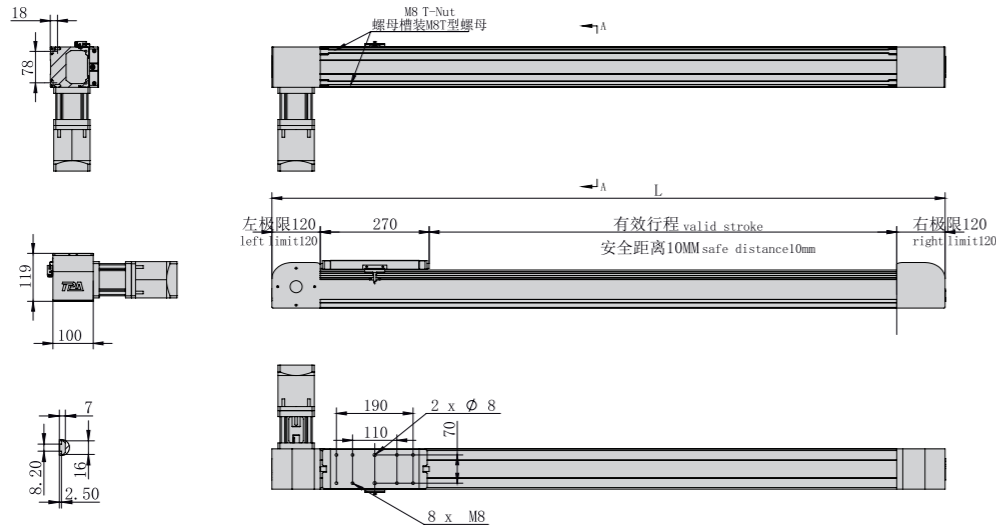

*不含电机和安装板重量 *Excluding motor and mounting plate weight

有效行程 Stroke	150	250	350	450	550	650	750	850	950	1050	1150	1250	1350	1450	1550
L	670	770	870	970	1070	1170	1270	1370	1470	1570	1670	1770	1870	1970	2070
KG	23	23.7	24.4	25.1	25.8	26.5	27.2	27.9	28.6	29.3	30	30.7	31.4	32.1	32.8

有效行程 Stroke	1650	1750	1850	1950	2050	2150	2250	2350	2450	2550	2650	2750	2850	2950	3050
L	2170	2270	2370	2470	2570	2670	2770	2870	2970	3070	3170	3270	3370	3470	3570
KG	33.5	34.2	34.9	35.6	36.3	37	37.7	38.4	39.1	39.8	40.5	41.2	41.9	42.6	43.3

DR 电机右侧 Motor right side

单位:Unit: mm

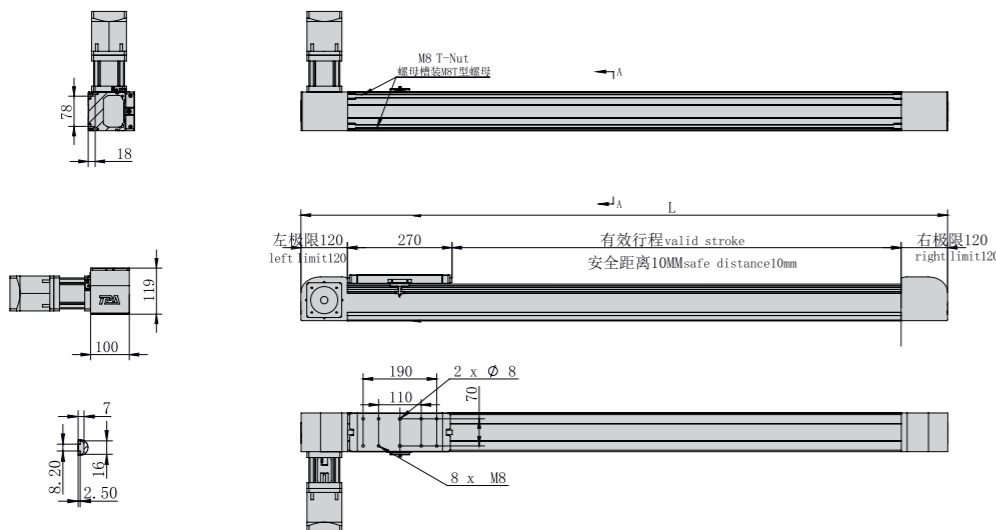

*不含电机和安装板重量 *Excluding motor and mounting plate weight

有效行程 Stroke	150	250	350	450	550	650	750	850	950	1050	1150	1250	1350	1450	1550
L	670	770	870	970	1070	1170	1270	1370	1470	1570	1670	1770	1870	1970	2070
KG	23	23.7	24.4	25.1	25.8	26.5	27.2	27.9	28.6	29.3	30	30.7	31.4	32.1	32.8

有效行程 Stroke	1650	1750	1850	1950	2050	2150	2250	2350	2450	2550	2650	2750	2850	2950	3050
L	2170	2270	2370	2470	2570	2670	2770	2870	2970	3070	3170	3270	3370	3470	3570
KG	33.5	34.2	34.9	35.6	36.3	37	37.7	38.4	39.1	39.8	40.5	41.2	41.9	42.6	43.3

MEMO

ONB

OCB

参考资料
Reference
data



此图仅供参考, 出货规格详见尺寸图面
This picture for reference only, specs details according with the drawing.

- 最大行程 Max Stroke: 4050mm
- 最高速度 Max Speed: 12800mm/s
- 马达容量 Motor Output: 750W
- 皮带宽度 Belt Width: 60mm
- 直线滑轨 Linear Guide: 30X26-1支

型号表达方式 Ordering method

TPA-ONB-120-256-L4050-DL-Y-P75B-N3-F

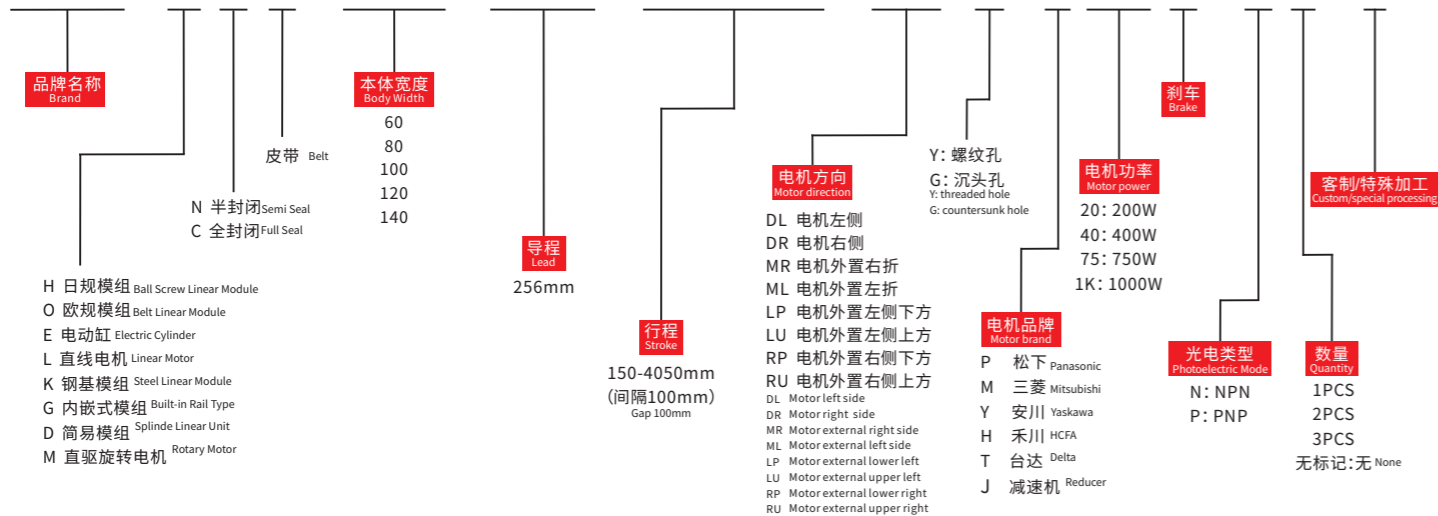

产品性能参数如下 Product performance parameters are as follows

规格 Spec	重复定位精度 (mm) Repeated positioning accuracy (mm)	±0.05					
	马达转速 (rpm/min) Rated Speed (rpm/min)	500	1000	1500	2000	2500	3000
部品 Parts	最高速度 (mm/s) Maximum speed (mm/s)	2100	4300	6400	8500	10700	12800
	最大可搬重量 (kg) Maximum Payload	水平使用 (kg) Horizontal (kg)					
	导程 (mm) lead (mm)	256					
	定格推力 (N) Rated thrust (N)	47					
	标准行程 (mm) Stroke pitch (mm)	150~4050mm/100 间隔 100 mm Pitch					
	AC伺服马达容量 (W) AC servo motor output (w)	750					
部品 Parts	皮带宽度 (mm) Belt Width (mm)	60					
	高刚性直线滑轨 (mm) High rigidity linear guide(mm)	30X26					
	原点感应器 Home sensor	外挂 Outside	672 (NPN)				

※1 马达加减速设定0.4秒。
※1 Acceleration and deceleration value is set 0.4 second.

容许负载力矩表 N.m Allowable overhang

各行程M5后装螺帽数量 M5 nuts Qty.(by stroke)		150~950	150~1450	150~1950	2050~2450	2550~4050
有效行程 Stroke	数量 Quantity	6	8	10	12	20

※滑台标准固定方式为下锁式, 使用M5后装螺帽固定。
※Standard mounting method is fix from the bottom, using the M5 bolt and nut.

容许负载力矩表 N.m Allowable overhang



水平安装 Horizontal installation		线速度 Speed Maximum	A	B	C	侧面安装 Horizontal installation		线速度 Speed Maximum	A	B	C
导程 78 Lead	1kg	12800mm/s	-	-	-	导程 78 Lead	1kg	12800mm/s	-	-	-
	2kg	10700mm/s	-	-	-		2kg	10700mm/s	-	-	-
	6kg	8500mm/s	-	-	-		6kg	8500mm/s	-	-	-
	10kg	6400mm/s	-	-	-		10kg	6400mm/s	-	-	-
	20kg	4300mm/s	-	-	-		20kg	4300mm/s	-	-	-
	35kg	2100mm/s	-	-	-		35kg	2100mm/s	-	-	-

搭配伺服马达一览表 Suitable motor brand

品牌 Brand	马达记号 Mark	刹车有无 Brake	马达容量 Motor capacity	电源电压 AC-Voltage	伺服马达型号 Servo motor model	驱动器型号 Driver Model
三菱 Mitsubishi	M	无刹车(水平式样) No brake (horizontal type)	750	220	HG-KR73	MR-J4-70A
松下 Panasonic	P	无刹车(水平式样) No brake (horizontal type)	750	220	MHMD082G1U	MBDHT3520
台达 Delta	T	无刹车(水平式样) No brake (horizontal type)	750	220	ECMA-C20807ES	ASD-B20721-B

速度-荷重曲线图 Acceleration-payload relationship

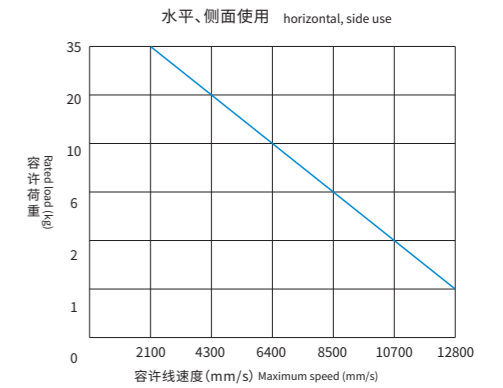

※以上使用条件请参考下方力矩表(最大值不可同时存在)。
※Please refer to the moment diagram below.(Do not reach all maximum value at same time.)

安装示意图 Installation diagram

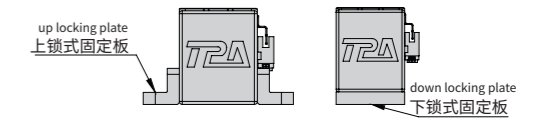

※上锁式固定板非标准品, 若有需求请另外追加选购。
※Top fixing plate is optional.

静态容许负载惯量 Static loading moment

MY	MP	MR
47	47	10

※力矩表所表示的数据, 代表重心。
The torque value in the chart indicate the center of gravity.
※符合型录规范的正常试用下, 保证寿命为10000公里。
Operation life is 10,000km when the product is using under the specified conditions.
※侧吊使用无法套用标准规范, 如有需求请咨询我司业务。
The standard specification cannot be applied to the use of inverted crane.
Please consult our business if necessary.



电机左侧/电机右侧
Motor left side / Motor right side

DL 电机左侧 Motor left side

单位:Unit: mm

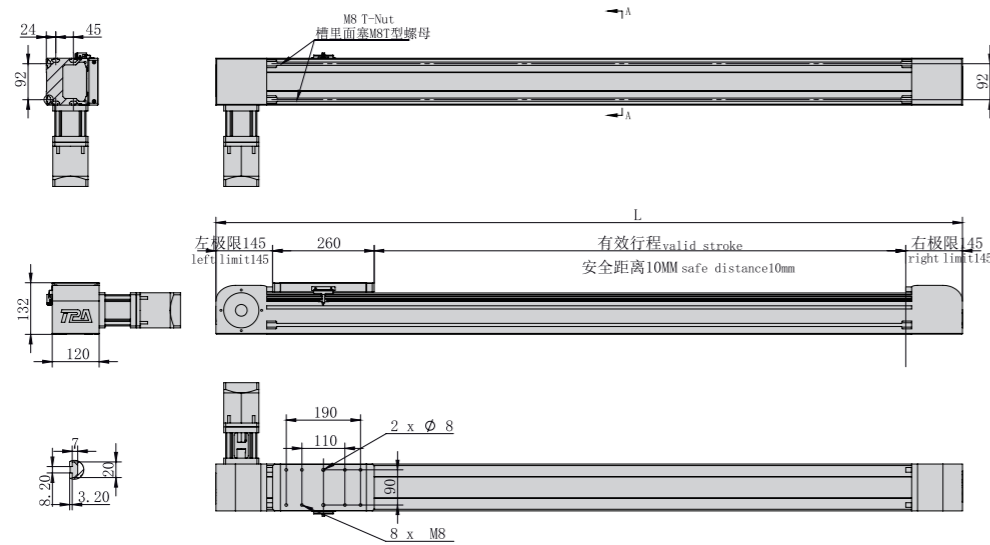

*不含电机和安装板重量 *Excluding motor and mounting plate weight

有效行程 Stroke	150	250	350	450	550	650	750	850	950	1050	1150	1250	1350	1450	1550	1650	1750	1850	1950	2050
L	710	810	910	1010	1110	1210	1310	1410	1510	1610	1710	1810	1910	2010	2110	2210	2310	2410	2510	2610
KG	27.1	28.6	30.1	31.6	33.1	34.6	36.1	37.6	39.1	40.6	42.1	43.6	45.1	46.6	48.1	49.6	51.1	52.6	54.1	55.6

有效行程 Stroke	2150	2250	2350	2450	2550	2650	2750	2850	2950	3050	3150	3250	3350	3450	3550	3650	3750	3850	3950	4050
L	2710	2810	2910	3010	3110	3210	3310	3410	3510	3610	3710	3810	3910	4010	4110	4210	4310	4410	4510	4610
KG	57.1	58.6	60.1	61.6	63.1	64.6	66.1	67.6	69.1	70.6	72.1	73.6	75.1	76.6	78.1	79.6	81.1	82.6	84.1	85.6

DR 电机右侧 Motor right side

单位:Unit: mm

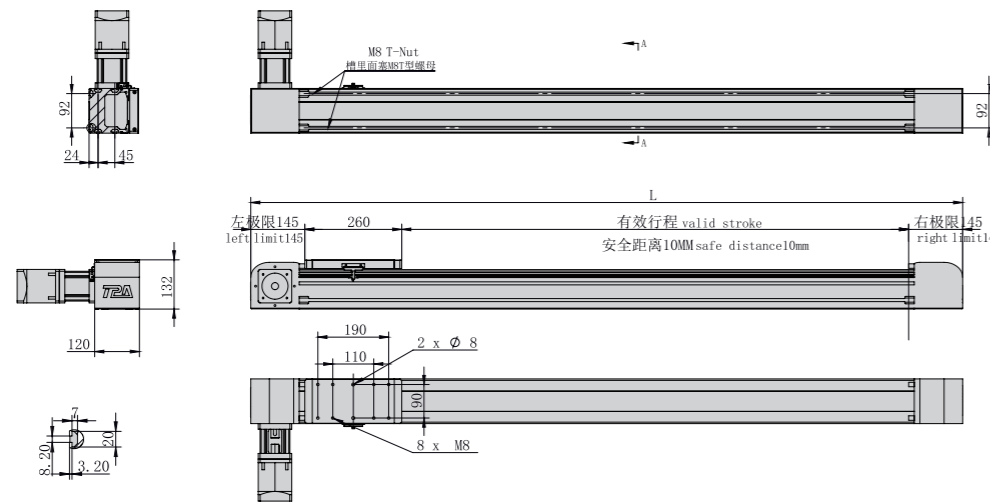

*不含电机和安装板重量 *Excluding motor and mounting plate weight

有效行程 Stroke	150	250	350	450	550	650	750	850	950	1050	1150	1250	1350	1450	1550	1650	1750	1850	1950	2050
L	710	810	910	1010	1110	1210	1310	1410	1510	1610	1710	1810	1910	2010	2110	2210	2310	2410	2510	2610
KG	27.1	28.6	30.1	31.6	33.1	34.6	36.1	37.6	39.1	40.6	42.1	43.6	45.1	46.6	48.1	49.6	51.1	52.6	54.1	55.6

有效行程 Stroke	2150	2250	2350	2450	2550	2650	2750	2850	2950	3050	3150	3250	3350	3450	3550	3650	3750	3850	3950	4050
L	2710	2810	2910	3010	3110	3210	3310	3410	3510	3610	3710	3810	3910	4010	4110	4210	4310	4410	4510	4610
KG	57.1	58.6	60.1	61.6	63.1	64.6	66.1	67.6	69.1	70.6	72.1	73.6	75.1	76.6	78.1	79.6	81.1	82.6	84.1	85.6

MEMO

ONB

OCB

参考资料
Reference
data



重复精度
Repeat Accuracy
±0.05 mm

此图仅供参考, 出货规格详见尺寸图面
This picture for reference only, specs details according with the drawing.

- 最大行程 Max Stroke: 5050mm
- 最高速度 Max Speed: 12800mm/s
- 马达容量 Motor Output: 750W
- 皮带宽度 Belt Width: 78mm
- 直线滑轨 Linear Guide: 30X26-1支

型号表达方式 Ordering method

TPA-ONB-140-256-L5050-DL-Y-P75B-N3-F

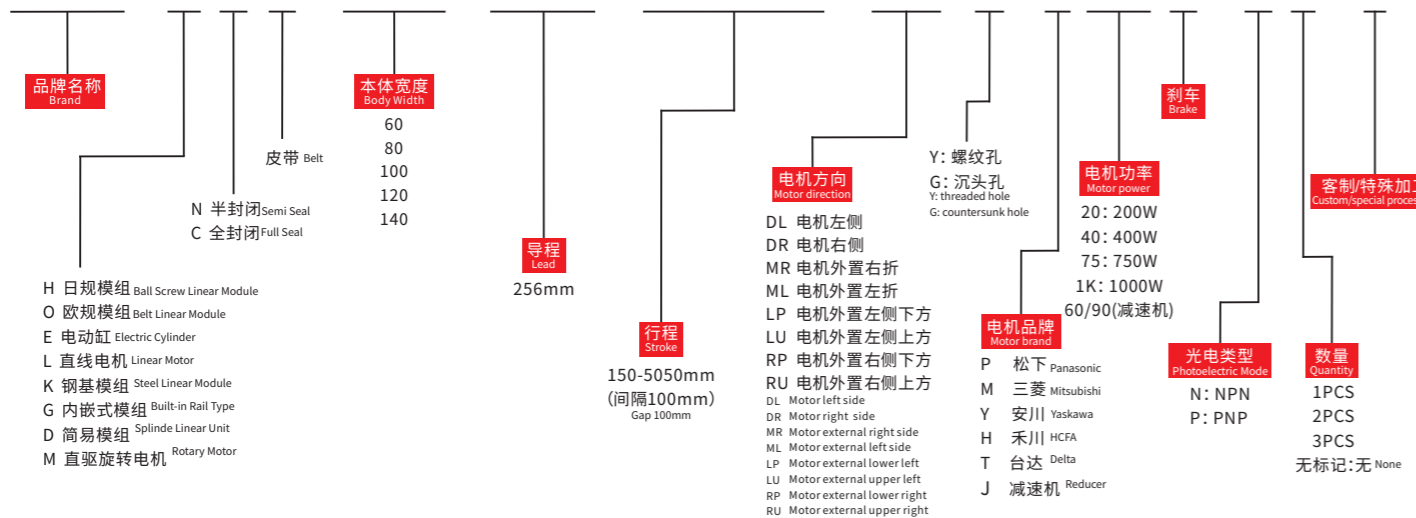

产品性能参数如下 Product performance parameters are as follows

规格 Spec	重复定位精度 (mm) Repeated positioning accuracy (mm)	±0.05					
	马达转速 (rpm/min) Rated Speed (rpm/min)	500	1000	1500	2000	2500	3000
	最高速度 (mm/s) Maximum speed (mm/s)	2100	4300	6400	8500	10700	12800
	最大可搬重量 Maximum Payload	水平使用 (kg) Horizontal (kg)					
部品 Parts	导程 (mm) lead (mm)	256					
	定格推力 (N) Rated thrust (N)	47					
	标准行程 (mm) Stroke pitch (mm)	150~5050mm/100 间隔 100 mm Pitch					
	AC伺服马达容量 (W) AC servo motor output (w)	750					
	皮带宽度 (mm) Belt Width (mm)	78					
	高刚性直线滑轨 (mm) High rigidity linear guide(mm)	30X26					
原点对应器 Home sensor	外挂 Outside	672(NPN)					

※1 马达加减速设定0.4秒。
※1 Acceleration and deceleration value is set 0.4 second.

容许负载力矩表 N.m Allowable overhang

各行程M5后装螺帽数量 M5 nuts Qty.(by stroke)		150~950	150~1450	150~1950	2050~2450	2550~5050
有效行程 Stroke	数量 Quantity	6	8	10	12	20

※滑台标准固定方式为下锁式, 使用M5后装螺帽固定。
※Standard mounting method is fix from the bottom, using the M5 bolt and nut.

容许负载力矩表 N.m Allowable overhang



水平安装 Horizontal installation		线速度 Speed Maximum	A	B	C	侧面安装 Horizontal installation		线速度 Speed Maximum	A	B	C
导程 256 Lead	1kg	12800mm/s	-	-	-	导程 256 Lead	1kg	12800mm/s	-	-	-
	2kg	10700mm/s	-	-	-		2kg	10700mm/s	-	-	-
	10kg	8500mm/s	-	-	-		10kg	8500mm/s	-	-	-
	15kg	6400mm/s	-	-	-		15kg	6400mm/s	-	-	-
	30kg	4300mm/s	-	-	-		30kg	4300mm/s	-	-	-
	40kg	2100mm/s	-	-	-		40kg	2100mm/s	-	-	-

搭配伺服马达一览表 Suitable motor brand

品牌 Brand	马达记号 Mark	刹车有无 Brake	马达容量 Motor capacity	电源电压 AC-Voltage	伺服马达型号 Servo motor model	驱动器型号 Driver Model
三菱 Mitsubishi	M	无刹车(水平式样) No brake (horizontal type)	400	220	HG-KR43	MR-J4-40A
松下 Panasonic	P	无刹车(水平式样) No brake (horizontal type)	400	220	MHMD042G1U	MBDHT2510
台达 Delta	T	无刹车(水平式样) No brake (horizontal type)	400	220	ECMA-C20604ES	ASD-B20421-B

速度-荷重曲线图 Acceleration-payload relationship

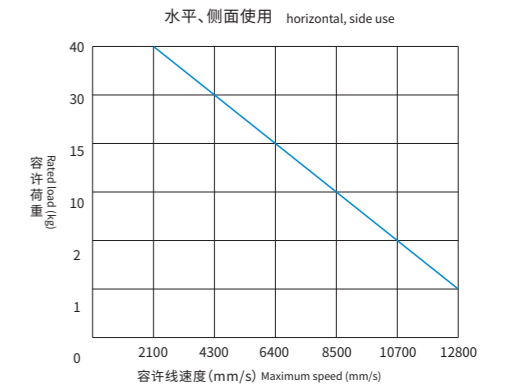

※以上使用条件请参考下方力矩表(最大值不可同时存在)。
※Please refer to the moment diagram below.(Do not reach all maximum value at same time.)

安装示意图 Installation diagram

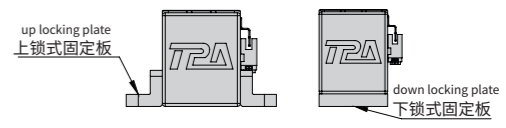

※上锁式固定板非标准品, 若有需求请另外追加选购。
※Top fixing plate is optional.

静态容许负载惯量 Static loading moment

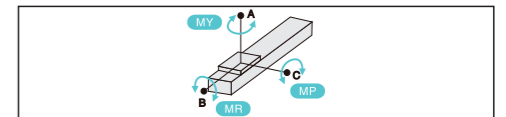

点	惯量 (单位Unit:N.m)
MY	50
MP	50
MR	15

※力矩表所表示的数据, 代表重心。
The torque value in the chart indicate the center of gravity.
※符合型录规范的正常试用下, 保证寿命为10000公里。
Operation life is 10,000km when the product is using under the specified conditions.
※侧吊使用无法套用标准规范, 如有需求请咨询我司业务。
The standard specification cannot be applied to the use of inverted crane.
Please consult our business if necessary.



电机左侧/电机右侧
Motor left side / Motor right side

DL 电机左侧 Motor left side

单位:Unit: mm

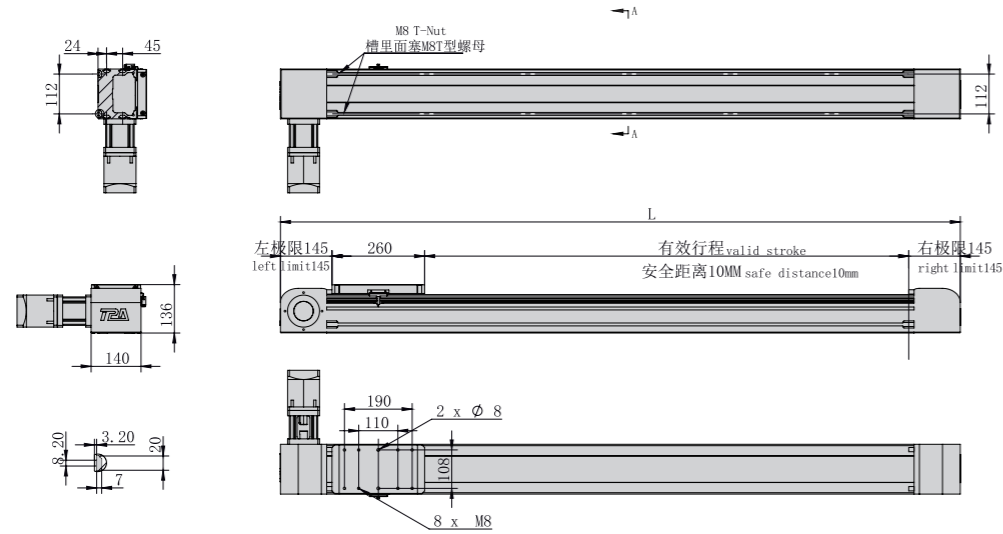

*不含电机和安装板重量 *Excluding motor and mounting plate weight

有效行程 Stroke	150	250	350	450	550	650	750	850	950	1050	1150	1250	1350	1450	1550	1650	1750	1850	1950	2050	2150	2250	2350	2450	2550
L	710	810	910	1010	1110	1210	1310	1410	1510	1610	1710	1810	1910	2010	2110	2210	2310	2410	2510	2610	2710	2810	2910	3010	3110
KG	26.3	28.1	29.9	31.7	33.5	35.3	37.1	38.9	40.7	42.5	44.3	46.1	47.9	49.7	51.5	53.3	55.1	56.9	58.7	60.5	62.3	64.1	65.9	67.7	69.5

有效行程 Stroke	2650	2750	2850	2950	3050	3150	3250	3350	3450	3550	3650	3750	3850	3950	4050	4150	4250	4350	4450	4550	4650	4750	4850	4950	5050
L	3210	3310	3410	3510	3610	3710	3810	3910	4010	4110	4210	4310	4410	4510	4610	4710	4810	4910	5010	5110	5210	5310	5410	5510	5610
KG	71.3	73.1	74.9	76.7	78.5	80.3	82.1	83.9	85.7	87.5	89.3	91.1	92.9	94.7	96.5	98.3	100.1	101.9	103.7	105.5	107.3	109.1	110.9	112.7	114.5

DR 电机右侧 Motor right side

单位:Unit: mm

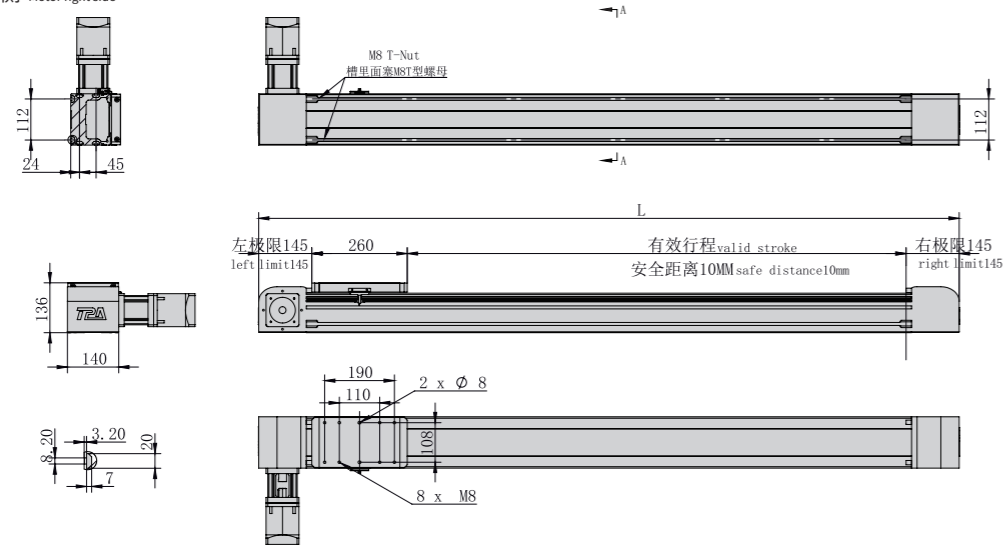

*不含电机和安装板重量 *Excluding motor and mounting plate weight

有效行程 Stroke	150	250	350	450	550	650	750	850	950	1050	1150	1250	1350	1450	1550	1650	1750	1850	1950	2050	2150	2250	2350	2450	2550
L	710	810	910	1010	1110	1210	1310	1410	1510	1610	1710	1810	1910	2010	2110	2210	2310	2410	2510	2610	2710	2810	2910	3010	3110
KG	26.3	28.1	29.9	31.7	33.5	35.3	37.1	38.9	40.7	42.5	44.3	46.1	47.9	49.7	51.5	53.3	55.1	56.9	58.7	60.5	62.3	64.1	65.9	67.7	69.5

有效行程 Stroke	2650	2750	2850	2950	3050	3150	3250	3350	3450	3550	3650	3750	3850	3950	4050	4150	4250	4350	4450	4550	4650	4750	4850	4950	5050
L	3210	3310	3410	3510	3610	3710	3810	3910	4010	4110	4210	4310	4410	4510	4610	4710	4810	4910	5010	5110	5210	5310	5410	5510	5610
KG	71.3	73.1	74.9	76.7	78.5	80.3	82.1	83.9	85.7	87.5	89.3	91.1	92.9	94.7	96.5	98.3	100.1	101.9	103.7	105.5	107.3	109.1	110.9	112.7	114.5

MEMO

ONB

OCB

参考资料
Reference data



重复精度
Repeat Accuracy
±0.05 mm

此图仅供参考, 出货规格详见尺寸图面
This picture for reference only, specs details according with the drawing.

最大行程
Max Stroke **3050mm**

最高速度
Max Speed **2333mm/s**

马达容量
Motor Output **400W**

皮带宽度
Belt Width **23mm**

直线滑轨
Linear Guide **15X12.5-1支**

型号表达方式 Ordering method

TPA-ONB-60-140-L3050-MR-Y-P40B-N3-F

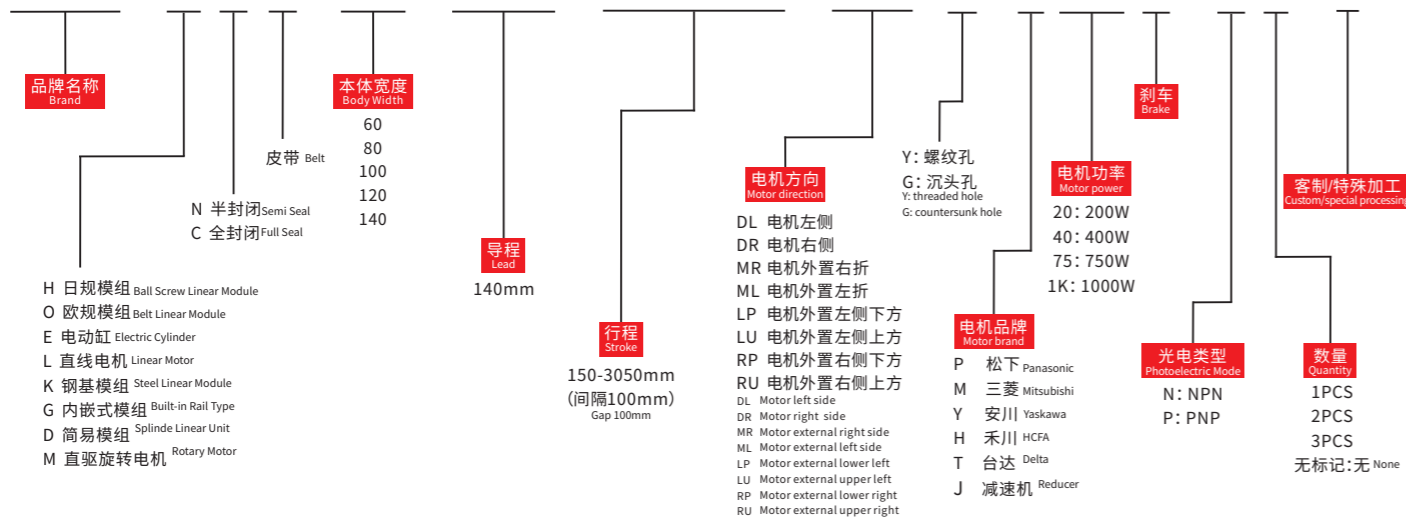

产品性能参数如下 Product performance parameters are as follows

规格 Spec	重复定位精度 (mm) Repeated positioning accuracy (mm)	±0.05			
	马达转速 (rpm/min) Rated Speed (rpm/min)	3:1	5:1	7:1	10:1
最大可搬重量 Maximum Payload	水平使用 (kg) Horizontal (kg)	32	47	58	63
	垂直使用 (kg) Vertical (kg) ※2	11	17	18	20
导程 (mm) lead (mm)	140				
定格推力 (N) Rated thrust (N)	230				
标准行程 (mm) Stroke pitch (mm) ※3	150~3050mm/100 间隔 100 mm Pitch				
部品 Parts	AC伺服马达容量 (W) AC servo motor output (w)	400			
	皮带宽度 (mm) Belt Width(mm)	23			
	高刚性直线滑轨 (mm) High rigidity linear guide(mm)	15X12.5			
原点感应器 Home sensor	外挂 Outside	672(NPN)			

※1 马达加速设定0.4秒。 ※1 Acceleration and deceleration value is set 0.4 second.
 ※2 垂直使用时, 若皮带断裂, 承载物会有掉落的风险, 请留意。
 ※2 Notice, if the belt breaks, the moving parts will fall when the application is vertical.
 ※3 滑台未安装减速机时, 导程为110。 ※3 Lead is 110mm without gearbox.

容许负载力矩表 N.m Allowable overhang

各行程M5后装螺帽数量 M5 nuts Qty.(by stroke)			
有效行程 Stroke	数量 Quantity	有效行程 Stroke	数量 Quantity
150-500	4	2600-3050	14

※滑台标准固定方式为下锁式, 使用M5后装螺帽固定。
 ※Standard mounting method is fix from the bottom, using the M5 bolt and nut.

容许负载力矩表 N.m Allowable overhang

(单位Unit:mm)			
水平安装 Horizontal installation	A	B	C
3:1	10kg	958	258
	20kg	428	113
	32kg	258	63
5:1	25kg	958	148
	35kg	633	98
	47kg	458	63
7:1	28kg	1308	153
	40kg	858	98
	58kg	558	58
10:1	30kg	1858	153
	45kg	1258	98
	63kg	808	58

(单位Unit:mm)			
侧面安装 Side mounting	A	B	C
3:1	10kg	50	258
	20kg	27	118
	32kg	18	68
5:1	25kg	33	148
	35kg	23	98
	47kg	18	68
7:1	28kg	33	153
	40kg	23	98
	58kg	18	68
10:1	30kg	33	148
	45kg	23	98
	63kg	18	68

(单位Unit:mm)			
垂直安装 Vertical installation	A	C	
3:1	3kg	908	908
	6kg	458	458
	11kg	308	308
5:1	5kg	908	908
	10kg	458	458
	17kg	308	308
7:1	6kg	908	908
	12kg	458	458
	18kg	308	308
10:1	6kg	908	908
	13kg	458	458
	20kg	338	338

速度-荷重曲线图 Acceleration-payload relationship

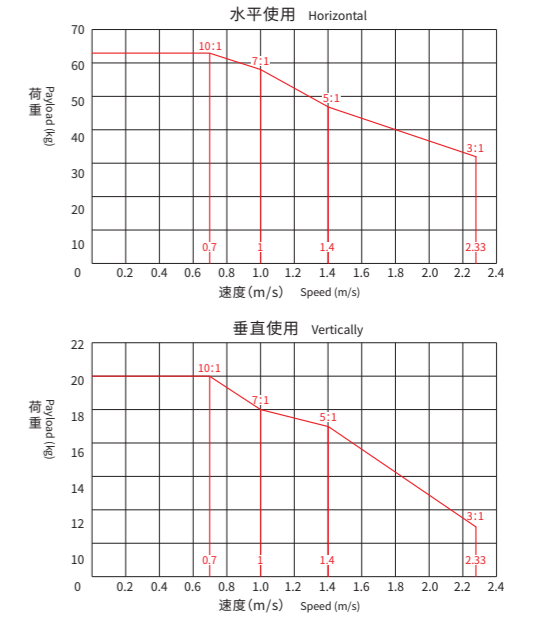

安装示意图 Installation diagram

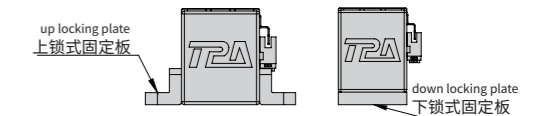

※上锁式固定板非标准品, 若有需求请另外追加选购。
 ※Top fixing plate is optional.

静态容许负载惯量 Static loading moment

(单位Unit:N.m)		
MY		340
MP		340
MR		62

*力矩表所表示的数据, 代表重心。
 The torque value in the chart indicate the center of gravity.
 *符合型录规范的正常试用下, 保证寿命为10000公里。
 Operation life is 10,000km when the product is using under the specified conditions.
 *倒吊使用无法套用标准规范, 如有需求请咨询我司业务。
 The standard specification cannot be applied to the use of inverted crane.
 Please consult our business if necessary.

电机外置左侧/电机外置右侧
Motor external left side / Motor external right side

ML 电机外置左侧 Motor external left side

单位:Unit: mm

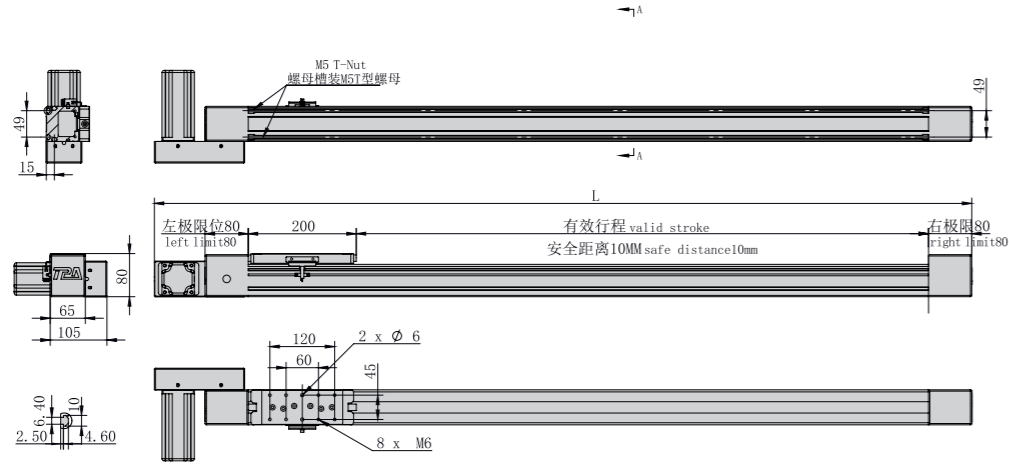

*不含电机和安装板重量 *Excluding motor and mounting plate weight

有效行程 Stroke	150	250	350	450	550	650	750	850	950	1050	1150	1250	1350	1450	1550
L	614	714	814	914	1014	1114	1214	1314	1414	1514	1614	1714	1814	1914	2014
KG	4.5	5	5.5	6	6.5	7	7.5	8	8.5	9	9.5	10	10.5	11	11.5

有效行程 Stroke	1650	1750	1850	1950	2050	2150	2250	2350	2450	2550	2650	2750	2850	2950	3050
L	2114	2214	2314	2414	2514	2614	2714	2814	2914	3014	3114	3214	3314	3414	3514
KG	12	12.5	13	13.5	14	14.5	15	15.5	16	16.5	17	17.5	18	18.5	19

电机外置左下/电机外置左上
Motor external lower left / Motor external upper left

LP 电机外置左下 Motor external lower left

单位:Unit: mm

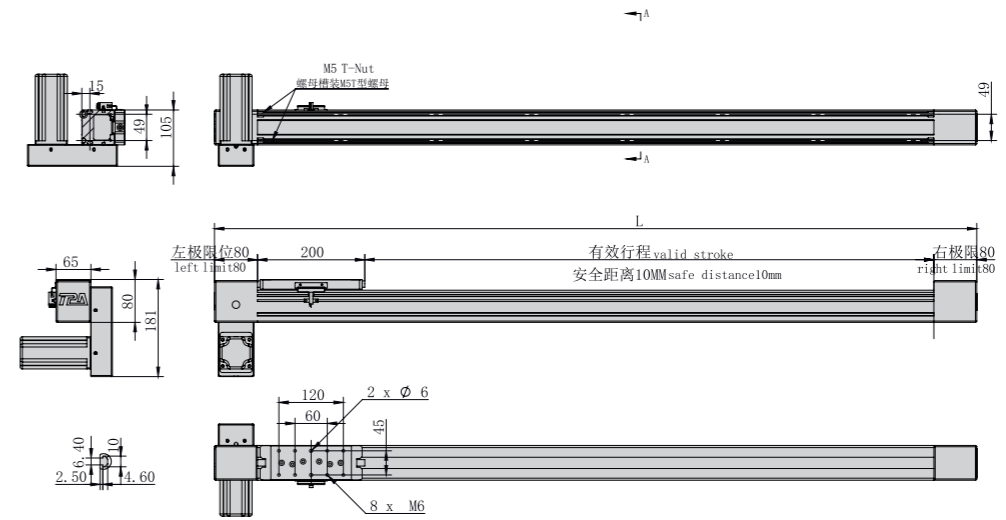

*不含电机和安装板重量 *Excluding motor and mounting plate weight

有效行程 Stroke	150	250	350	450	550	650	750	850	950	1050	1150	1250	1350	1450	1550
L	520	620	720	820	920	1020	1120	1220	1320	1420	1520	1620	1720	1820	1920
KG	4.5	5	5.5	6	6.5	7	7.5	8	8.5	9	9.5	10	10.5	11	11.5

有效行程 Stroke	1650	1750	1850	1950	2050	2150	2250	2350	2450	2550	2650	2750	2850	2950	3050
L	2020	2120	2220	2320	2420	2520	2620	2720	2820	2920	3020	3120	3220	3320	3420
KG	12	12.5	13	13.5	14	14.5	15	15.5	16	16.5	17	17.5	18	18.5	19

MR 电机外置右侧 Motor external right side

单位:Unit: mm

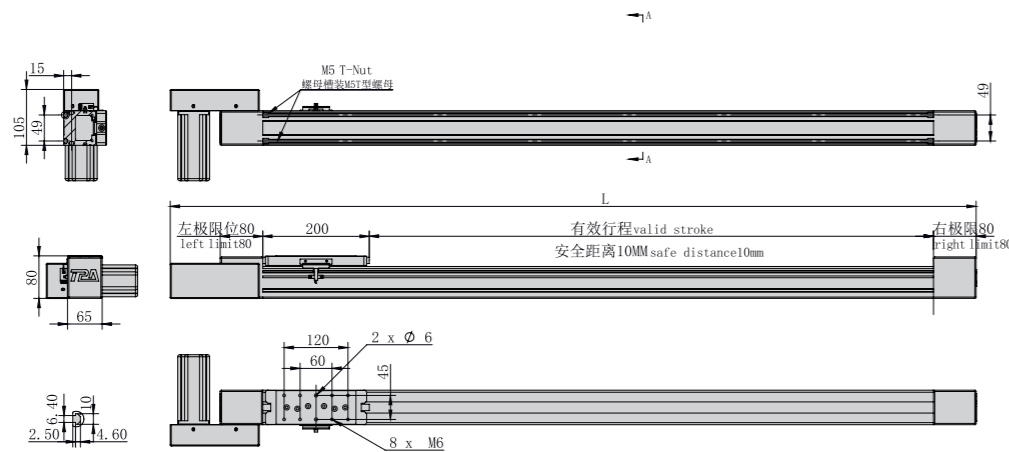

*不含电机和安装板重量 *Excluding motor and mounting plate weight

有效行程 Stroke	150	250	350	450	550	650	750	850	950	1050	1150	1250	1350	1450	1550
L	614	714	814	914	1014	1114	1214	1314	1414	1514	1614	1714	1814	1914	2014
KG	4.5	5	5.5	6	6.5	7	7.5	8	8.5	9	9.5	10	10.5	11	11.5

有效行程 Stroke	1650	1750	1850	1950	2050	2150	2250	2350	2450	2550	2650	2750	2850	2950	3050
L	2114	2214	2314	2414	2514	2614	2714	2814	2914	3014	3114	3214	3314	3414	3514
KG	12	12.5	13	13.5	14	14.5	15	15.5	16	16.5	17	17.5	18	18.5	19

LU 电机外置左上 Motor external upper left

单位:Unit: mm

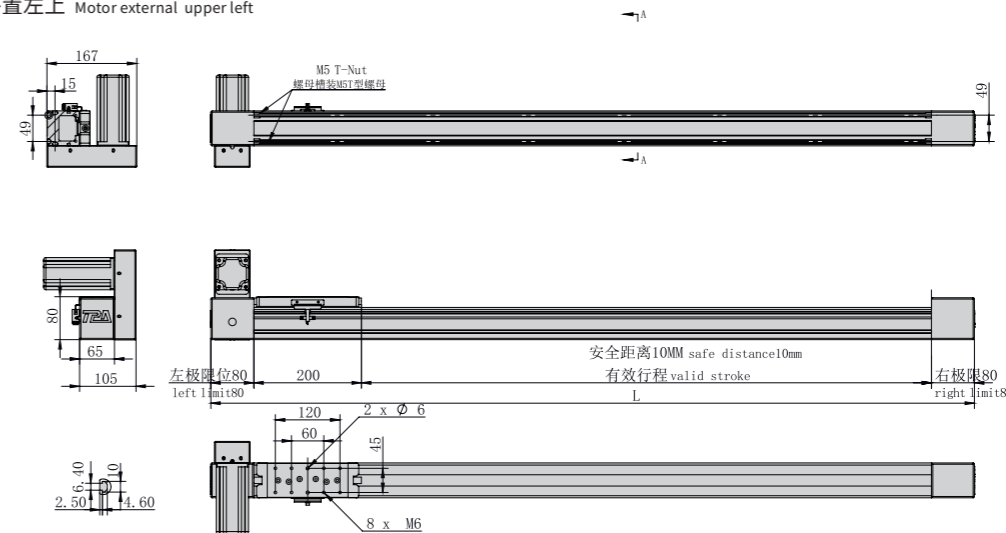

*不含电机和安装板重量 *Excluding motor and mounting plate weight

有效行程 Stroke	150	250	350	450	550	650	750	850	950	1050	1150	1250	1350	1450	1550
L	520	620	720	820	920	1020	1120	1220	1320	1420	1520	1620	1720	1820	1920
KG	4.5	5	5.5	6	6.5	7	7.5	8	8.5	9	9.5	10	10.5	11	11.5

有效行程 Stroke	1650	1750	1850	1950	2050	2150	2250	2350	2450	2550	2650	2750	2850	2950	3050
L	2020	2120	2220	2320	2420	2520	2620	2720	2820	2920	3020	3120	3220	3320	3420
KG	12	12.5	13	13.5	14	14.5	15	15.5	16	16.5	17	17.5	18	18.5	19



电机外置右下/电机外置右上
Motor external lower right / Motor external upper right

RP 电机外置右下 Motor external lower right

单位:Unit: mm

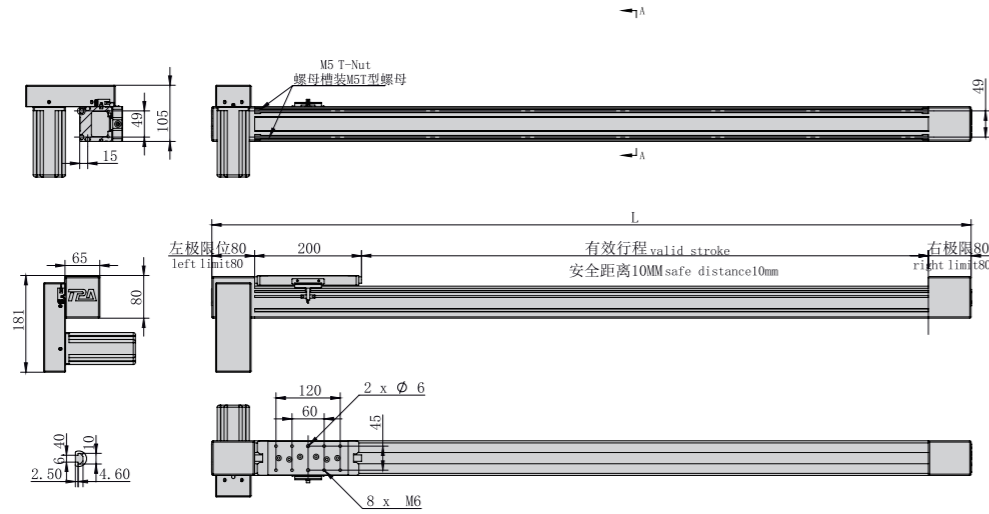

*不含电机和安装板重量 *Excluding motor and mounting plate weight

有效行程 Stroke	150	250	350	450	550	650	750	850	950	1050	1150	1250	1350	1450	1550
L	520	620	720	820	920	1020	1120	1220	1320	1420	1520	1620	1720	1820	1920
KG	4.5	5	5.5	6	6.5	7	7.5	8	8.5	9	9.5	10	10.5	11	11.5

有效行程 Stroke	1650	1750	1850	1950	2050	2150	2250	2350	2450	2550	2650	2750	2850	2950	3050
L	2020	2120	2220	2320	2420	2520	2620	2720	2820	2920	3020	3120	3220	3320	3420
KG	12	12.5	13	13.5	14	14.5	15	15.5	16	16.5	17	17.5	18	18.5	19

RU 电机外置右上 Motor external upper right

单位:Unit: mm

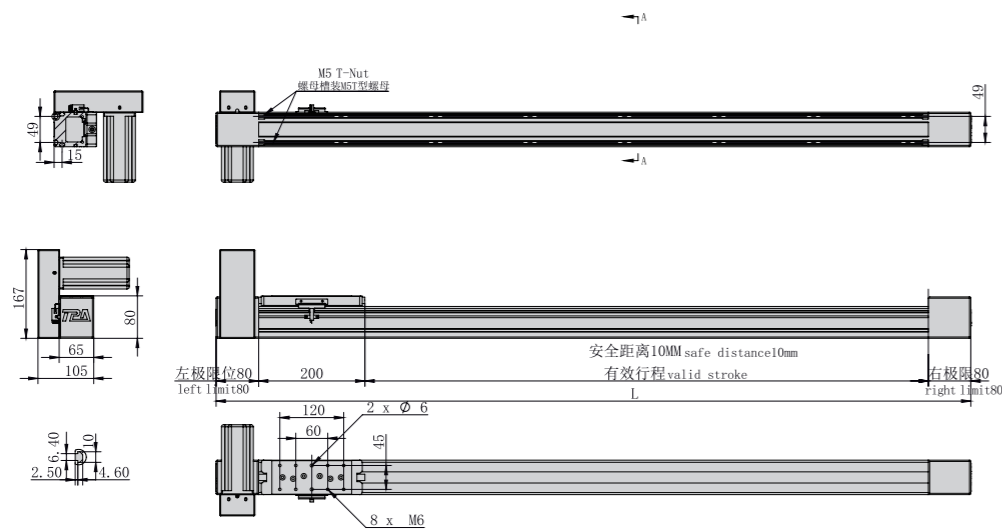

*不含电机和安装板重量 *Excluding motor and mounting plate weight

有效行程 Stroke	150	250	350	450	550	650	750	850	950	1050	1150	1250	1350	1450	1550
L	520	620	720	820	920	1020	1120	1220	1320	1420	1520	1620	1720	1820	1920
KG	4.5	5	5.5	6	6.5	7	7.5	8	8.5	9	9.5	10	10.5	11	11.5

有效行程 Stroke	1650	1750	1850	1950	2050	2150	2250	2350	2450	2550	2650	2750	2850	2950	3050
L	2020	2120	2220	2320	2420	2520	2620	2720	2820	2920	3020	3120	3220	3320	3420
KG	12	12.5	13	13.5	14	14.5	15	15.5	16	16.5	17	17.5	18	18.5	19

MEMO

ONB

OCB

参考资料
Reference
data



重复精度
Repeat Accuracy
±0.05 mm

此图仅供参考, 出货规格详见尺寸图面
This picture for reference only, specs details according with the drawing.

最大行程
Max Stroke **3050mm**

最高速度
Max Speed **1700mm/s**

马达容量
Motor Output **400W**

皮带宽度
Belt Width **38mm**

直线滑轨
Linear Guide **20X17.5-1支**

型号表达方式 Ordering method

TPA-ONB-80-170-L3050-DL-Y-P40B-N3-F

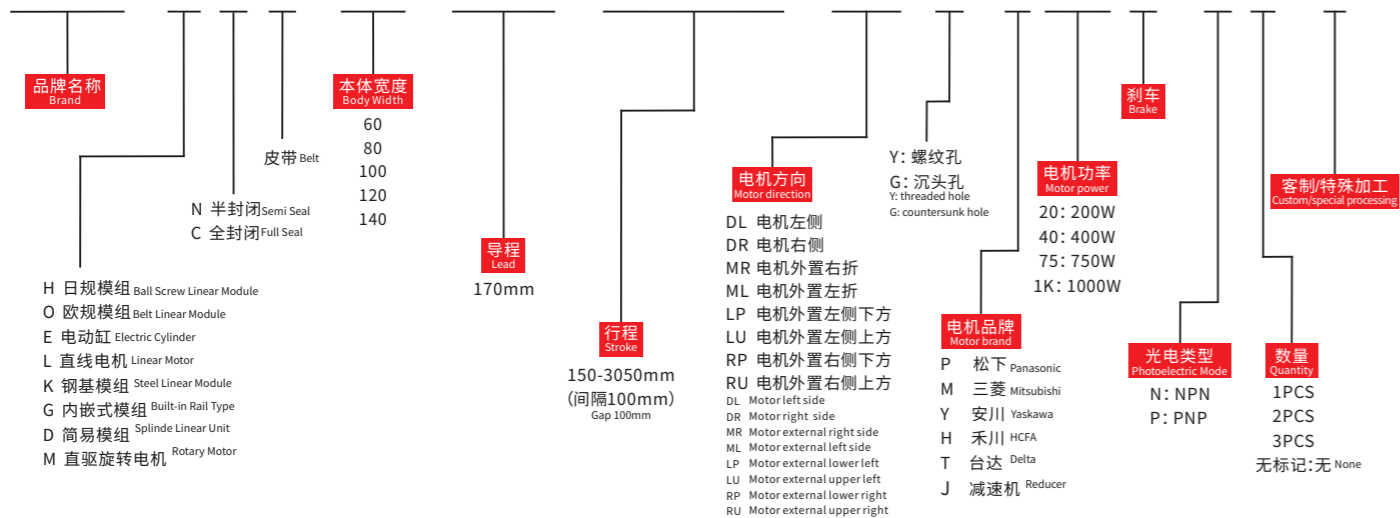

产品性能参数如下 Product performance parameters are as follows

规格 Spec	重复定位精度 (mm) Repeated positioning accuracy (mm)	±0.05		
	马达转速 (rpm) Rated Speed (rpm/min)	5:1	7:1	10:1
	最高速度 (mm/s) Maximum speed (mm/s)	1700	1214	850
	最大可搬重量 Maximum Payload	水平使用 (kg) Horizontal (kg)	43	63
部品 Parts	垂直使用 (kg) Vertical (kg) ^{※2}	18	20	22
	导程 (mm) lead (mm)	170		
	定格推力 (N) Rated thrust (N)	350		
	标准行程 (mm) Stroke pitch (mm) ^{※3}	150~3050mm/100 间隔 100 mm Pitch		
	AC伺服马达容量 (W) AC servo motor output (w)	400		
皮带宽度 (mm) Belt Width (mm)	38			
高刚性直线滑轨 (mm) High rigidity linear guide (mm)	20X17.5			
原点感应器 Home sensor	外挂 Outside	672(NPN)		

※1 马达加速设定0.4秒。※1 Acceleration and deceleration value is set 0.4 second.
 ※2 垂直使用时, 若皮带断裂, 承载物会有掉落危险, 请留意。
 ※2 Notice, if the belt breaks, the moving parts will fall when the application is vertical.
 ※3 滑台未安装减速机时, 导程为110。※3 Lead is 110mm without gearbox.

速度-荷重曲线图 Acceleration-payload relationship

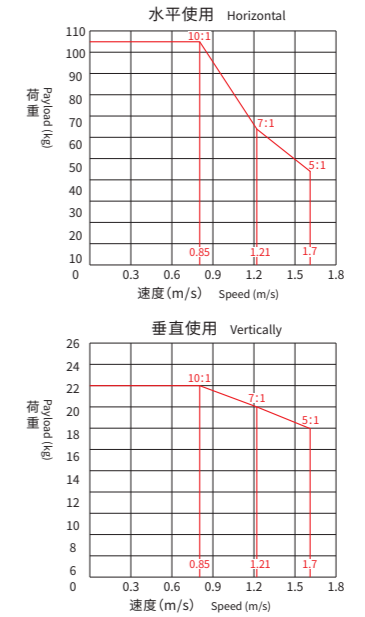

容许负载力矩表 N.m Allowable overhang

各行程M5后装螺帽数量 M5 nuts Qty.(by stroke)			
有效行程 Stroke	数量 Quantity	有效行程 Stroke	数量 Quantity
150-500	4	2600-3050	14

※滑台标准固定方式为下锁式, 使用M5后装螺帽固定。
 ※Standard mounting method is fix from the bottom, using the M5 bolt and nut.

安装示意图 Installation diagram

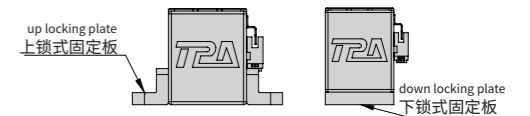

※上锁式固定板非标准品, 若有需求请另外追加选购。
 ※Top fixing plate is optional.

容许负载力矩表 N.m Allowable overhang

速度比	水平安装 Horizontal installation			侧面安装 Side mounting			垂直安装 Vertical installation		
	A	B	C	A	B	C	A	B	C
5:1	13kg	908	288	13kg	48	288	3kg	1258	1258
	28kg	558	168	28kg	30	168	8kg	658	658
	43kg	408	118	43kg	23	118	12kg	458	458
7:1	33kg	758	168	33kg	30	168	14kg	608	608
	48kg	575	123	48kg	23	118	16kg	488	488
	63kg	420	93	63kg	20	88	20kg	408	408
10:1	75kg	908	148	75kg	28	148	16kg	558	558
	90kg	708	113	90kg	23	113	18kg	458	458
	105kg	558	83	105kg	18	83	22kg	358	358

静态容许负载惯量 Static loading moment

惯量	容许值 (单位Unit:N.m)
MY	820
MP	820
MR	120

*力矩表所表示的数据, 代表重心。
 The torque value in the chart indicate the center of gravity.
 *符合型录规范的正常试用下, 保证寿命为10000公里。
 Operation life is 10,000km when the product is using under the specified conditions.
 *倒吊使用无法套用标准规范, 如有需求请咨询我司业务。
 The standard specification cannot be applied to the use of inverted crane. Please consult our business if necessary.

电机外置左侧/电机外置右侧
Motor external left side / Motor external right side

ML 电机外置左侧 Motor external left side

单位:Unit: mm

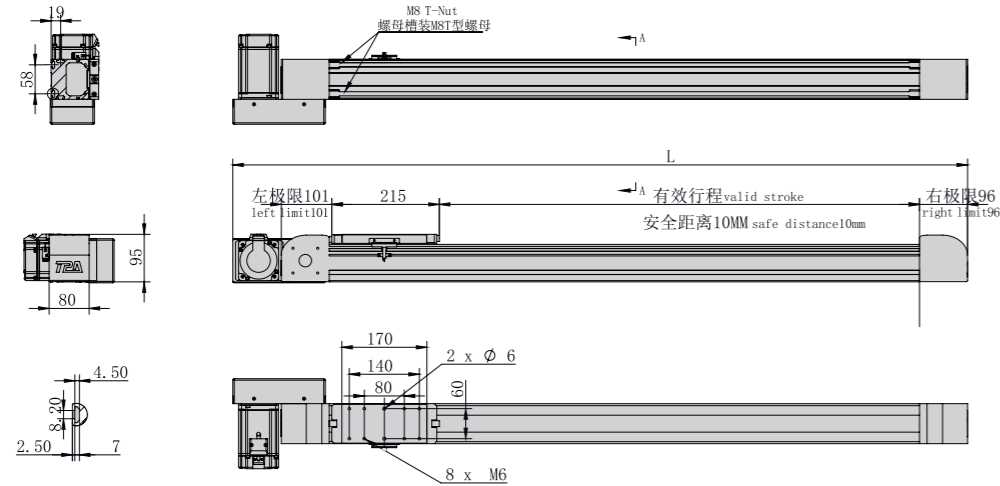

*不含电机和安装板重量 *Excluding motor and mounting plate weight

有效行程 Stroke	150	250	350	450	550	650	750	850	950	1050	1150	1250	1350	1450	1550
L	669	769	869	969	1069	1169	1269	1369	1469	1569	1669	1769	1869	1969	2069
KG	11.6	12.3	13	13.7	14.4	15.1	15.8	16.5	17.2	17.9	18.6	19.3	20	20.7	21.4

有效行程 Stroke	1650	1750	1850	1950	2050	2150	2250	2350	2450	2550	2650	2750	2850	2950	3050
L	2169	2269	2369	2469	2569	2669	2769	2869	2969	3069	3169	3269	3369	3469	3569
KG	22.1	22.8	23.5	24.2	24.9	25.6	26.3	27	27.7	28.4	29.1	29.8	30.5	31.2	31.9

电机外置左下/电机外置左上
Motor external lower left / Motor external upper left

LP 电机外置左下 Motor external lower left

单位:Unit: mm

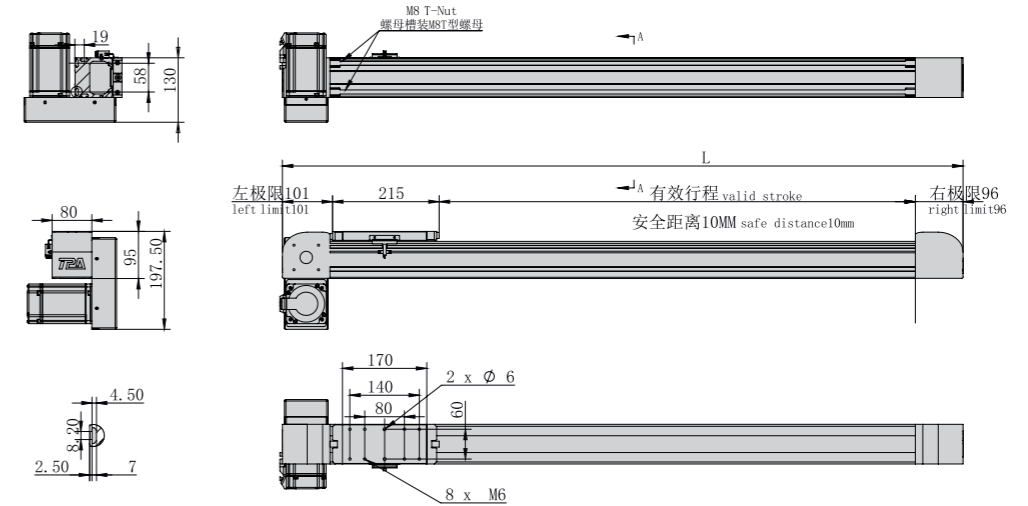

*不含电机和安装板重量 *Excluding motor and mounting plate weight

有效行程 Stroke	150	250	350	450	550	650	750	850	950	1050	1150	1250	1350	1450	1550
L	572	672	772	872	972	1072	1172	1272	1372	1472	1572	1672	1772	1872	1972
KG	11.6	12.3	13	13.7	14.4	15.1	15.8	16.5	17.2	17.9	18.6	19.3	20	20.7	21.4

有效行程 Stroke	1650	1750	1850	1950	2050	2150	2250	2350	2450	2550	2650	2750	2850	2950	3050
L	2072	2172	2272	2372	2472	2572	2672	2772	2872	2972	3072	3172	3272	3372	3472
KG	22.1	22.8	23.5	24.2	24.9	25.6	26.3	27	27.7	28.4	29.1	29.8	30.5	31.2	31.9

MR 电机外置右侧 Motor external right side

单位:Unit: mm

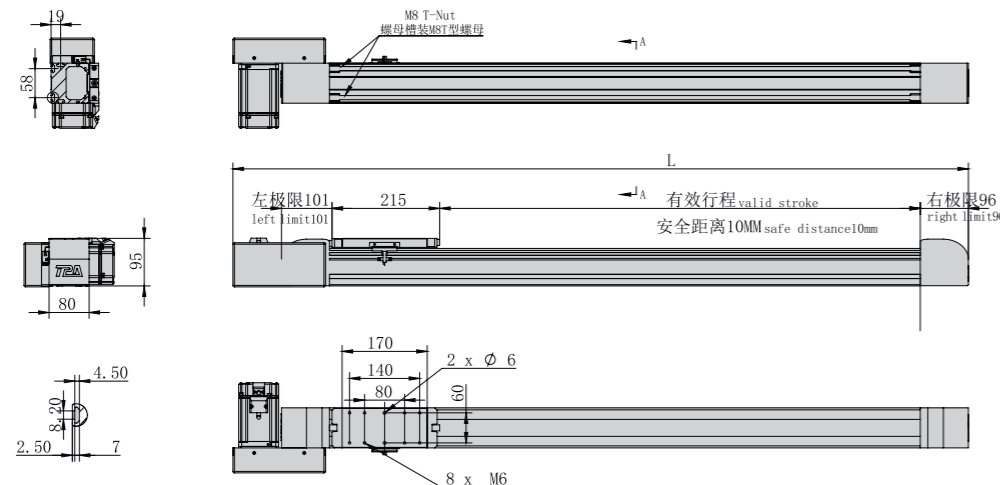

*不含电机和安装板重量 *Excluding motor and mounting plate weight

有效行程 Stroke	150	250	350	450	550	650	750	850	950	1050	1150	1250	1350	1450	1550
L	669	769	869	969	1069	1169	1269	1369	1469	1569	1669	1769	1869	1969	2069
KG	11.6	12.3	13	13.7	14.4	15.1	15.8	16.5	17.2	17.9	18.6	19.3	20	20.7	21.4

有效行程 Stroke	1650	1750	1850	1950	2050	2150	2250	2350	2450	2550	2650	2750	2850	2950	3050
L	2169	2269	2369	2469	2569	2669	2769	2869	2969	3069	3169	3269	3369	3469	3569
KG	22.1	22.8	23.5	24.2	24.9	25.6	26.3	27	27.7	28.4	29.1	29.8	30.5	31.2	31.9

LU 电机外置左上 Motor external upper left

单位:Unit: mm

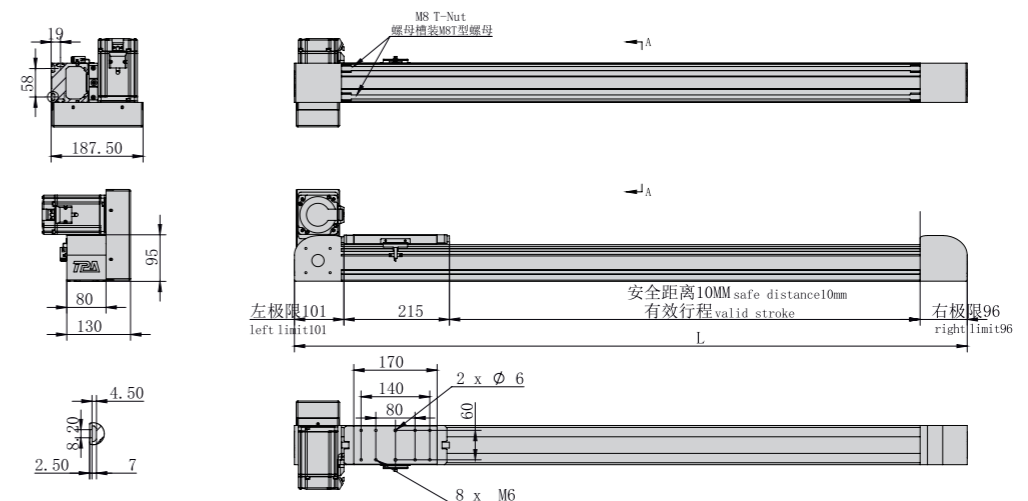

*不含电机和安装板重量 *Excluding motor and mounting plate weight

有效行程 Stroke	150	250	350	450	550	650	750	850	950	1050	1150	1250	1350	1450	1550
L	572	672	772	872	972	1072	1172	1272	1372	1472	1572	1672	1772	1872	1972
KG	11.6	12.3	13	13.7	14.4	15.1	15.8	16.5	17.2	17.9	18.6	19.3	20	20.7	21.4

有效行程 Stroke	1650	1750	1850	1950	2050	2150	2250	2350	2450	2550	2650	2750	2850	2950	3050
L	2072	2172	2272	2372	2472	2572	2672	2772	2872	2972	3072	3172	3272	3372	3472
KG	22.1	22.8	23.5	24.2	24.9	25.6	26.3	27	27.7	28.4	29.1	29.8	30.5	31.2	31.9



电机外置右下/电机外置右上
Motor external lower right / Motor external upper right

RP 电机外置右下 Motor external lower right

单位:Unit: mm

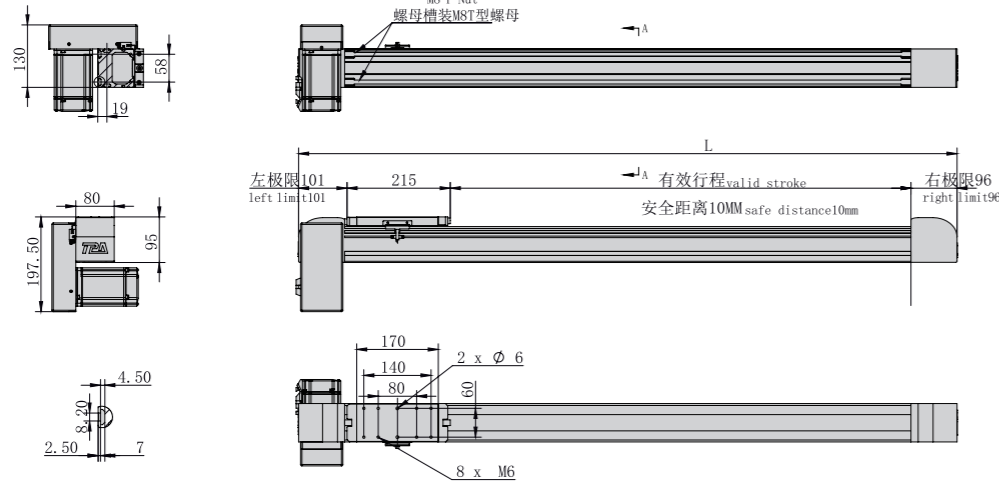

*不含电机和安装板重量 *Excluding motor and mounting plate weight

有效行程 Stroke	150	250	350	450	550	650	750	850	950	1050	1150	1250	1350	1450	1550
L	572	672	772	872	972	1072	1172	1272	1372	1472	1572	1672	1772	1872	1972
KG	11.6	12.3	13	13.7	14.4	15.1	15.8	16.5	17.2	17.9	18.6	19.3	20	20.7	21.4

有效行程 Stroke	1650	1750	1850	1950	2050	2150	2250	2350	2450	2550	2650	2750	2850	2950	3050
L	2072	2172	2272	2372	2472	2572	2672	2772	2872	2972	3072	3172	3272	3372	3472
KG	22.1	22.8	23.5	24.2	24.9	25.6	26.3	27	27.7	28.4	29.1	29.8	30.5	31.2	31.9

RU 电机外置右上 Motor external upper right

单位:Unit: mm

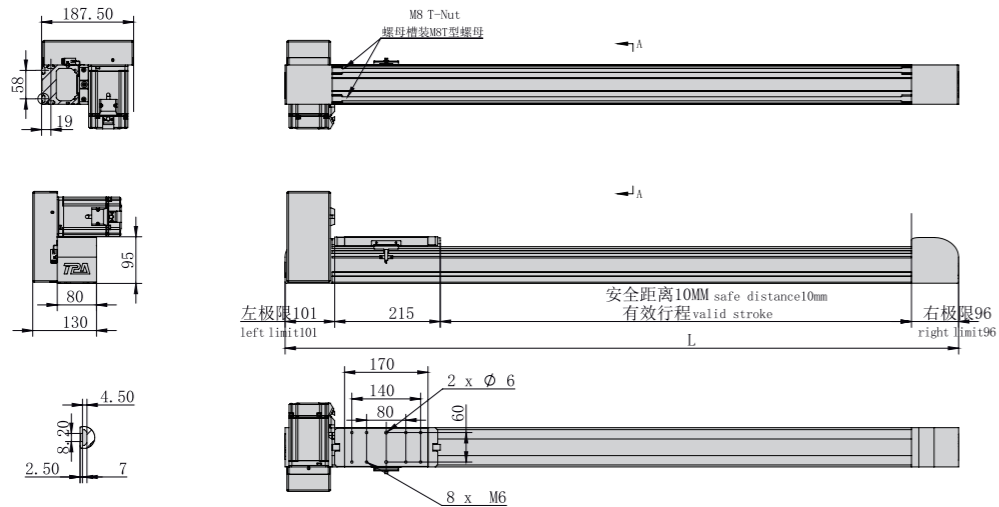

*不含电机和安装板重量 *Excluding motor and mounting plate weight

有效行程 Stroke	150	250	350	450	550	650	750	850	950	1050	1150	1250	1350	1450	1550
L	572	672	772	872	972	1072	1172	1272	1372	1472	1572	1672	1772	1872	1972
KG	11.6	12.3	13	13.7	14.4	15.1	15.8	16.5	17.2	17.9	18.6	19.3	20	20.7	21.4

有效行程 Stroke	1650	1750	1850	1950	2050	2150	2250	2350	2450	2550	2650	2750	2850	2950	3050
L	2072	2172	2272	2372	2472	2572	2672	2772	2872	2972	3072	3172	3272	3372	3472
KG	22.1	22.8	23.5	24.2	24.9	25.6	26.3	27	27.7	28.4	29.1	29.8	30.5	31.2	31.9

MEMO

ONB

OCB

参考资料
Reference
data

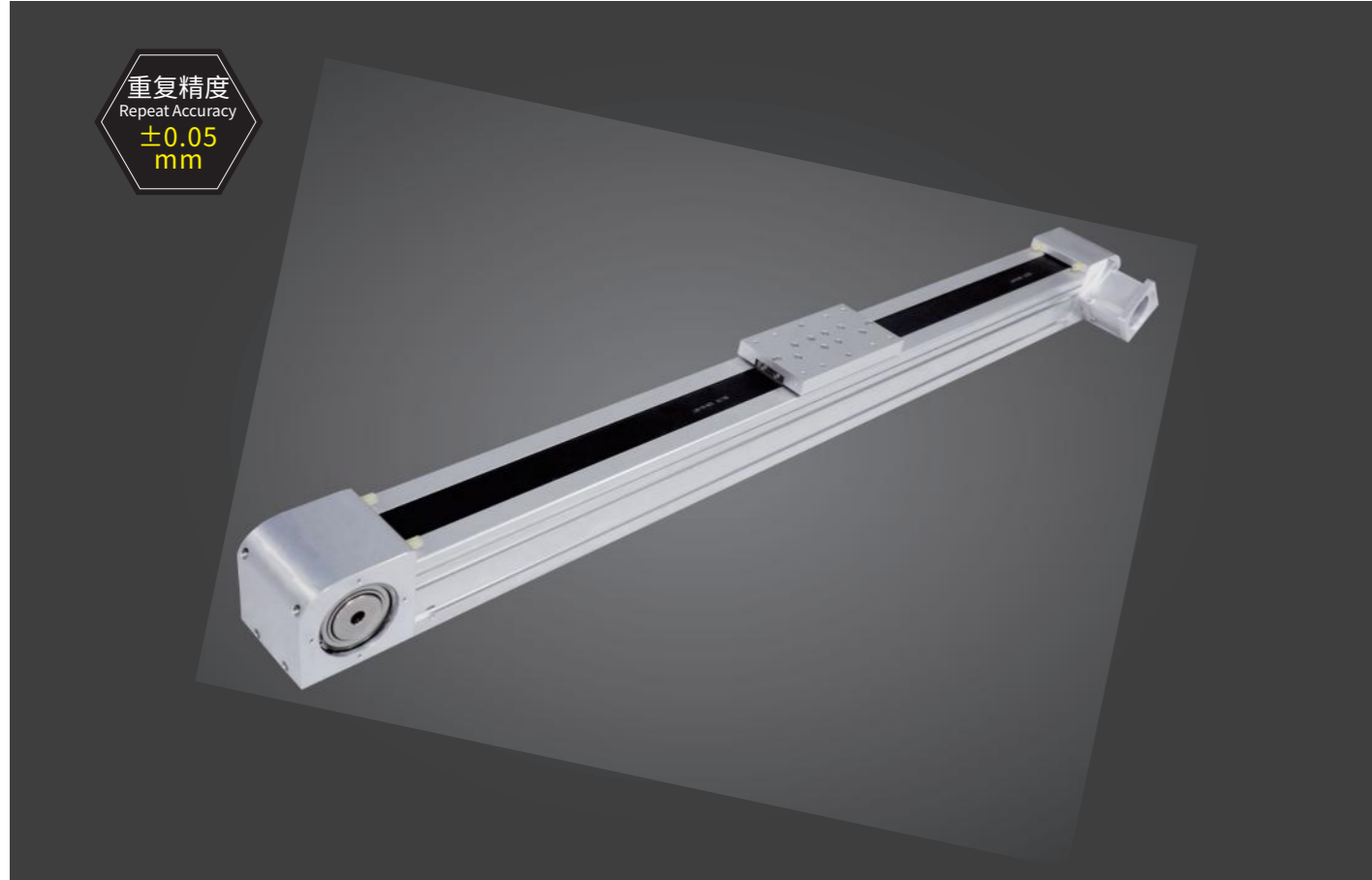

重复精度
Repeat Accuracy
±0.05 mm

此图仅供参考, 出货规格详见尺寸图面
This picture for reference only, specs details according with the drawing.

最大行程
Max Stroke **3050mm**

最高速度
Max Speed **2320mm/s**

马达容量
Motor Output **750W**

皮带宽度
Belt Width **50mm**

直线滑轨
Linear Guide **25X22-1支**

型号表达方式 Ordering method

TPA-ONB-100-232-L3050-MR-Y-P75B-N3-F

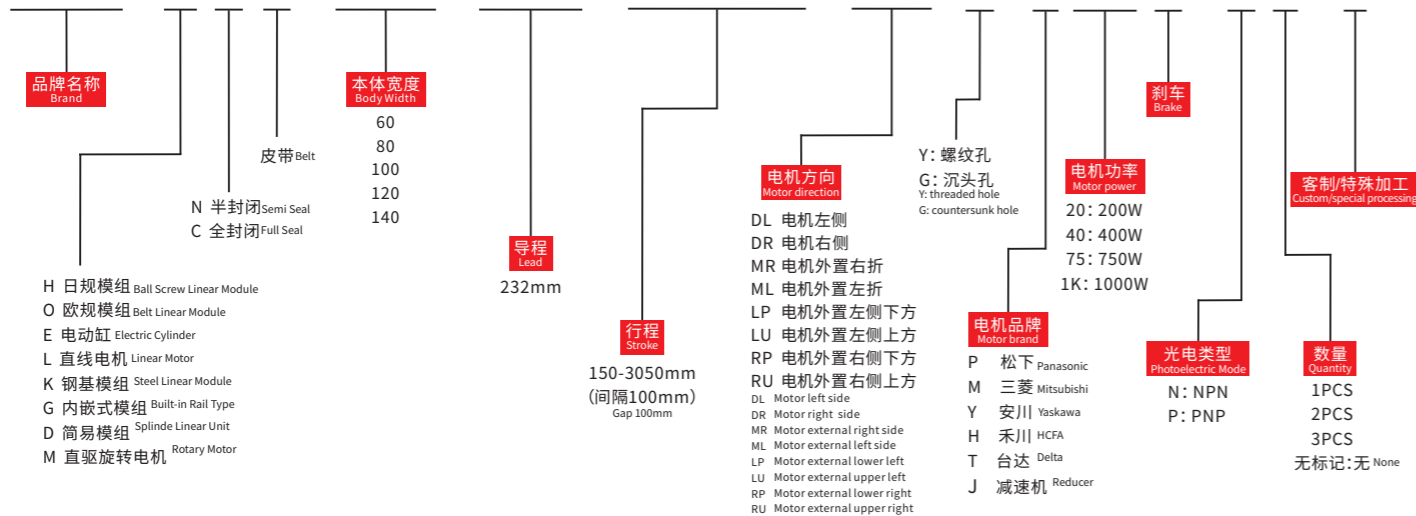

产品性能参数如下 Product performance parameters are as follows

规格 Spec	重复定位精度 (mm) Repeated positioning accuracy (mm)	±0.05		
	马达转速 (rpm) Rated Speed (rpm/min)	10:1	15:1	20:1
	最高速度 (mm/s) Maximum speed (mm/s)	2320	1657	1160
	最大可搬重量 Maximum Payload	水平使用 (kg) Horizontal (kg)	60	80
部品 Parts	垂直使用 (kg) Vertical (kg)	30	50	60
	导程 (mm) lead (mm)	232		
	定格推力 (N) Rated thrust (N)	500		
	标准行程 (mm) Stroke pitch (mm)	150~3050mm/100 间隔 100 mm Pitch		
	AC伺服马达容量 (W) AC servo motor output (w)	750		
部品 Parts	皮带宽度 (mm) Belt Width (mm)	50		
	高刚性直线滑轨 (mm) High rigidity linear guide (mm)	25X22		
	原点感应器 Home sensor	外挂 Outside	672(NPN)	

※1 马达加速设定0.4秒。※1 Acceleration and deceleration value is set 0.4 second.
 ※2 垂直使用时, 若皮带断裂, 承载物会有掉落危险, 请注意。
 ※2 Notice, if the belt breaks, the moving parts will fall when the application is vertical.
 ※3 滑台未安装减速机时, 导程为110。※3 Lead is 110mm without gearbox.

速度-荷重曲线图 Acceleration-payload relationship

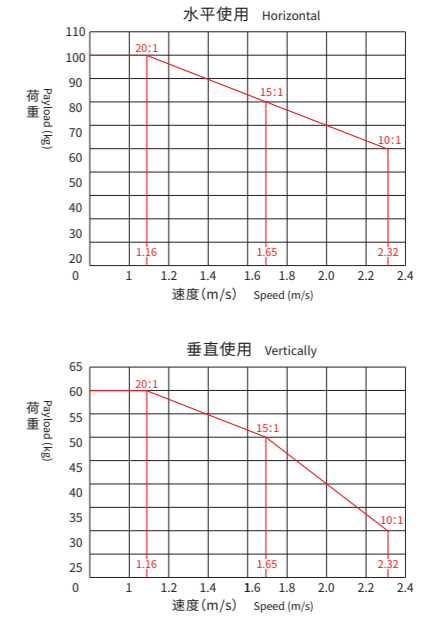

容许负载力矩表 N.m Allowable overhang

各行程M5后装螺帽数量 M5 nuts Qty.(by stroke)			
有效行程 Stroke	数量 Quantity	有效行程 Stroke	数量 Quantity
150-500	4	2600-3050	14

※滑台标准固定方式为下锁式, 使用M5后装螺帽固定。
 ※Standard mounting method is fix from the bottom, using the M5 bolt and nut.

安装示意图 Installation diagram

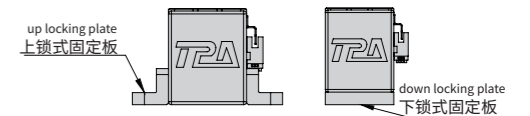

※上锁式固定板非标准品, 若有需求请另外追加选购。
 ※Top fixing plate is optional.

容许负载力矩表 N.m Allowable overhang

速度比	水平安装 Horizontal installation			侧面安装 Side mounting			垂直安装 Vertical installation				
	A	B	C	A	B	C	A	B	C		
10:1	30kg	1102	187	25	30kg	25	187	1102	5kg	1292	1292
	45kg	742	118	16	45kg	16	118	742	15kg	862	862
	60kg	542	77	11	60kg	11	77	542	30kg	672	672
15:1	50kg	1392	152	20	50kg	20	152	1392	20kg	1472	1472
	65kg	932	92	13	65kg	13	92	932	35kg	822	822
	80kg	642	55	8	80kg	8	55	642	50kg	567	567
20:1	70kg	1392	107	15	70kg	15	107	1392	30kg	742	742
	85kg	892	57	8	85kg	8	57	892	45kg	552	552
	100kg	542	27	5	100kg	5	27	542	60kg	442	442

静态容许负载惯量 Static loading moment

		(单位Unit:N.m)
MY		1100
MP		1100
MR		300

*力矩表所表示的数据, 代表重心。
 The torque value in the chart indicate the center of gravity.
 *符合型录规范的正常试用下, 保证寿命为10000公里。
 Operation life is 10,000km when the product is using under the specified conditions.
 *倒吊使用无法套用标准规范, 如有需求请咨询我司业务。
 The standard specification cannot be applied to the use of inverted crane. Please consult our business if necessary.

电机外置左侧/电机外置右侧
Motor external left side / Motor external right side

ML 电机外置左侧 Motor external left side

单位:Unit: mm

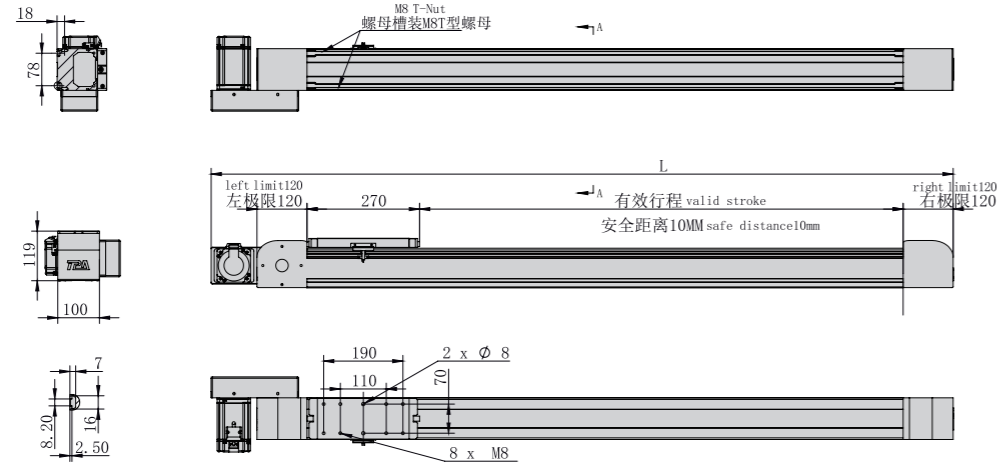

*不含电机和安装板重量 *Excluding motor and mounting plate weight

有效行程 Stroke	150	250	350	450	550	650	750	850	950	1050	1150	1250	1350	1450	1550
L	780	880	980	1080	1180	1280	1380	1480	1580	1680	1780	1880	1980	2080	2180
KG	24.5	25.2	25.9	26.6	27.3	28	28.7	29.4	30.1	30.8	31.5	32.2	32.9	33.6	34.3

有效行程 Stroke	1650	1750	1850	1950	2050	2150	2250	2350	2450	2550	2650	2750	2850	2950	3050
L	2280	2380	2480	2580	2680	2780	2880	2980	3080	3180	3280	3380	3480	3580	3680
KG	35	35.7	36.4	37.1	37.8	38.5	39.2	39.9	40.6	41.3	42	42.7	43.4	44.1	44.8

电机外置左下/电机外置左上
Motor external lower left / Motor external upper left

LP 电机外置左下 Motor external lower left

单位:Unit: mm

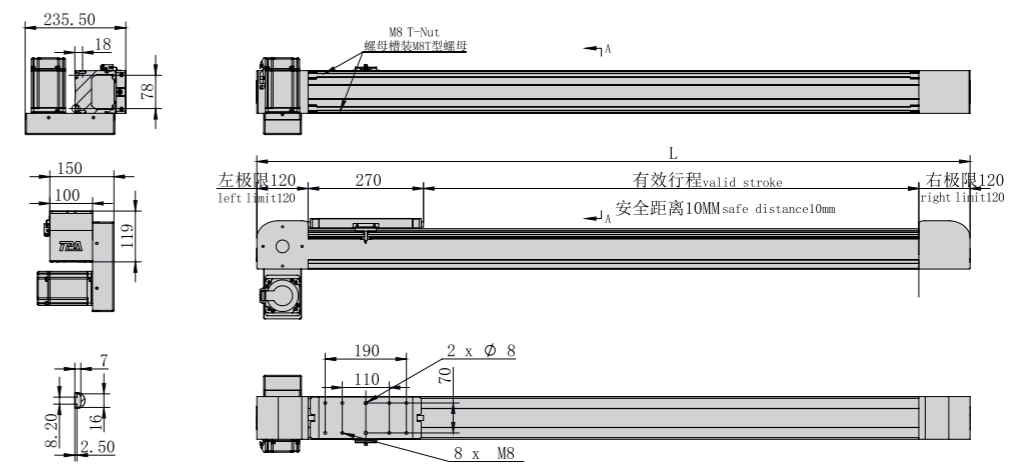

*不含电机和安装板重量 *Excluding motor and mounting plate weight

有效行程 Stroke	150	250	350	450	550	650	750	850	950	1050	1150	1250	1350	1450	1550
L	670	770	870	970	1070	1170	1270	1370	1470	1570	1670	1770	1870	1970	2070
KG	24.5	25.2	25.9	26.6	27.3	28	28.7	29.4	30.1	30.8	31.5	32.2	32.9	33.6	34.3

有效行程 Stroke	1650	1750	1850	1950	2050	2150	2250	2350	2450	2550	2650	2750	2850	2950	3050
L	2170	2270	2370	2470	2570	2670	2770	2870	2970	3070	3170	3270	3370	3470	3570
KG	35	35.7	36.4	37.1	37.8	38.5	39.2	39.9	40.6	41.3	42	42.7	43.4	44.1	44.8

MR 电机外置右侧 Motor external right side

单位:Unit: mm

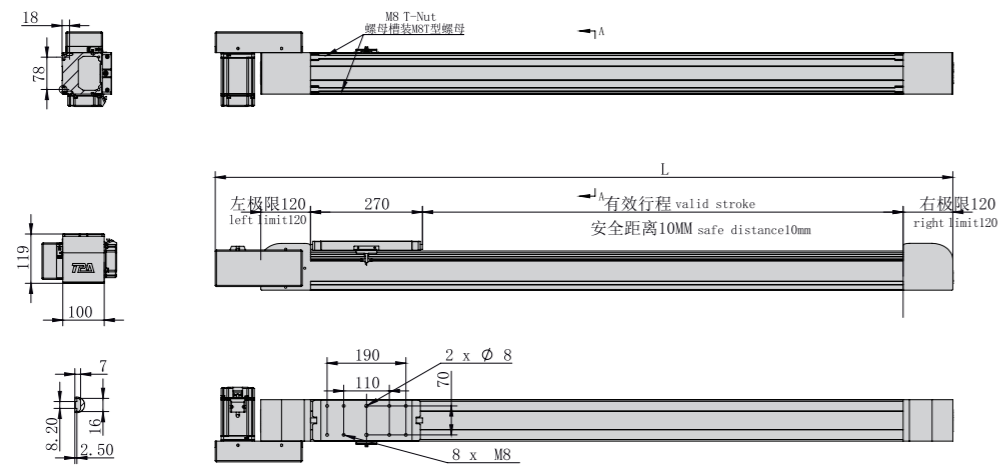

*不含电机和安装板重量 *Excluding motor and mounting plate weight

有效行程 Stroke	150	250	350	450	550	650	750	850	950	1050	1150	1250	1350	1450	1550
L	780	880	980	1080	1180	1280	1380	1480	1580	1680	1780	1880	1980	2080	2180
KG	24.5	25.2	25.9	26.6	27.3	28	28.7	29.4	30.1	30.8	31.5	32.2	32.9	33.6	34.3

有效行程 Stroke	1650	1750	1850	1950	2050	2150	2250	2350	2450	2550	2650	2750	2850	2950	3050
L	2280	2380	2480	2580	2680	2780	2880	2980	3080	3180	3280	3380	3480	3580	3680
KG	35	35.7	36.4	37.1	37.8	38.5	39.2	39.9	40.6	41.3	42	42.7	43.4	44.1	44.8

LU 电机外置左上 Motor external upper left

单位:Unit: mm

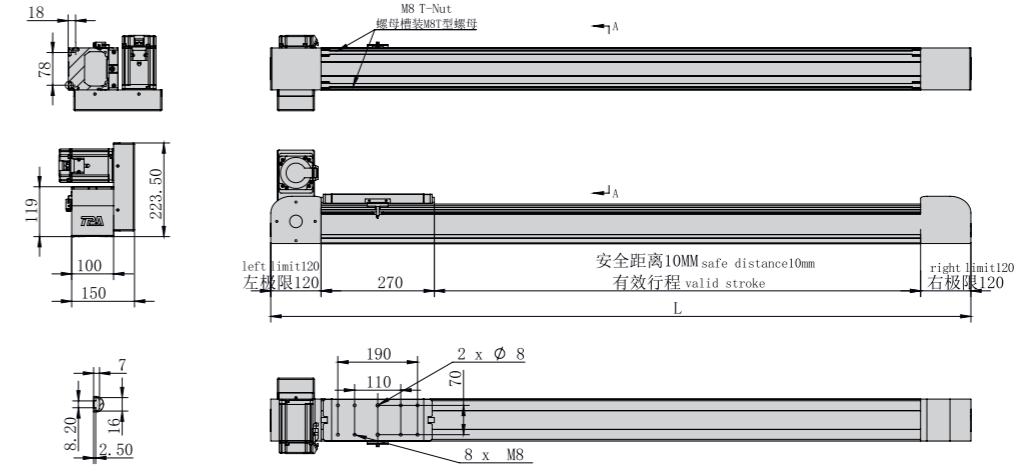

*不含电机和安装板重量 *Excluding motor and mounting plate weight

有效行程 Stroke	150	250	350	450	550	650	750	850	950	1050	1150	1250	1350	1450	1550
L	670	770	870	970	1070	1170	1270	1370	1470	1570	1670	1770	1870	1970	2070
KG	24.5	25.2	25.9	26.6	27.3	28	28.7	29.4	30.1	30.8	31.5	32.2	32.9	33.6	34.3

有效行程 Stroke	1650	1750	1850	1950	2050	2150	2250	2350	2450	2550	2650	2750	2850	2950	3050
L	2170	2270	2370	2470	2570	2670	2770	2870	2970	3070	3170	3270	3370	3470	3570
KG	35	35.7	36.4	37.1	37.8	38.5	39.2	39.9	40.6	41.3	42	42.7	43.4	44.1	44.8



电机外置右下/电机外置右上
Motor external lower right / Motor external upper right

RP 电机外置右下 Motor external lower right

单位:Unit: mm

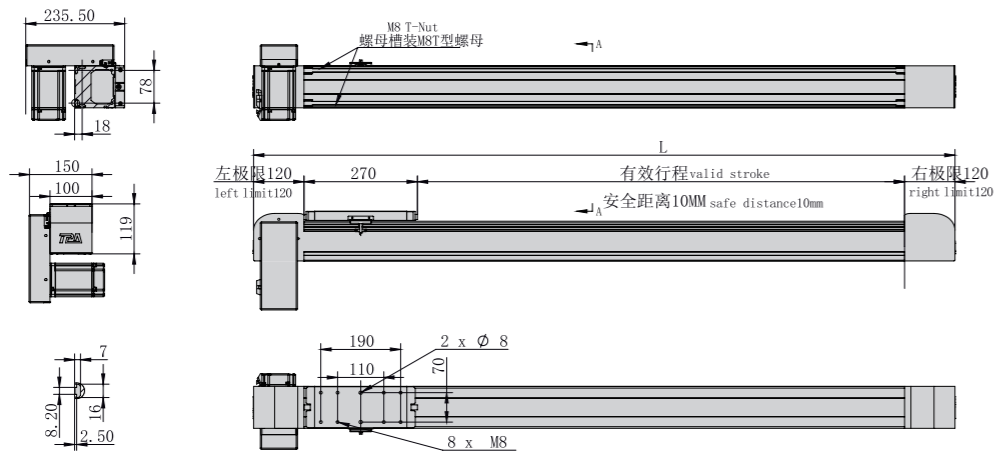

*不含电机和安装板重量 *Excluding motor and mounting plate weight

有效行程 Stroke	150	250	350	450	550	650	750	850	950	1050	1150	1250	1350	1450	1550
L	670	770	870	970	1070	1170	1270	1370	1470	1570	1670	1770	1870	1970	2070
KG	24.5	25.2	25.9	26.6	27.3	28	28.7	29.4	30.1	30.8	31.5	32.2	32.9	33.6	34.3

有效行程 Stroke	1650	1750	1850	1950	2050	2150	2250	2350	2450	2550	2650	2750	2850	2950	3050
L	2170	2270	2370	2470	2570	2670	2770	2870	2970	3070	3170	3270	3370	3470	3570
KG	35	35.7	36.4	37.1	37.8	38.5	39.2	39.9	40.6	41.3	42	42.7	43.4	44.1	44.8

RU 电机外置右上 Motor external upper right

单位:Unit: mm

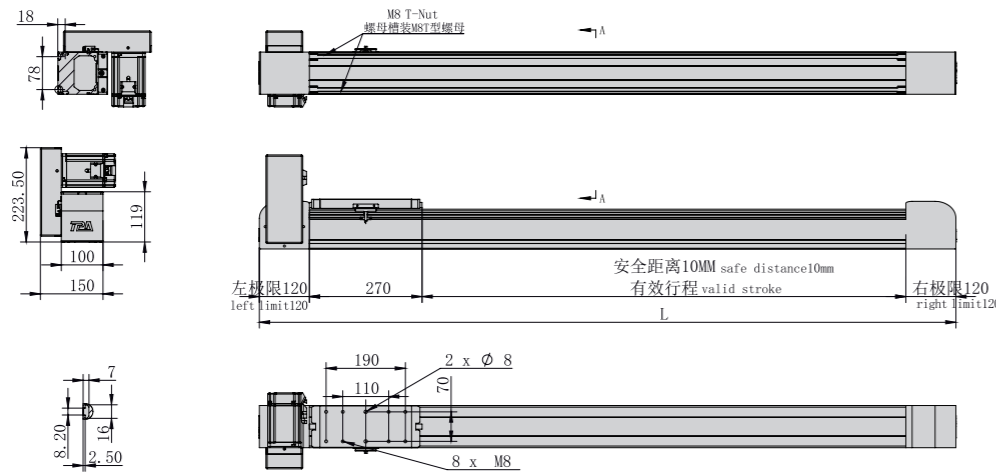

*不含电机和安装板重量 *Excluding motor and mounting plate weight

有效行程 Stroke	150	250	350	450	550	650	750	850	950	1050	1150	1250	1350	1450	1550
L	670	770	870	970	1070	1170	1270	1370	1470	1570	1670	1770	1870	1970	2070
KG	24.5	25.2	25.9	26.6	27.3	28	28.7	29.4	30.1	30.8	31.5	32.2	32.9	33.6	34.3

有效行程 Stroke	1650	1750	1850	1950	2050	2150	2250	2350	2450	2550	2650	2750	2850	2950	3050
L	2170	2270	2370	2470	2570	2670	2770	2870	2970	3070	3170	3270	3370	3470	3570
KG	35	35.7	36.4	37.1	37.8	38.5	39.2	39.9	40.6	41.3	42	42.7	43.4	44.1	44.8

MEMO

ONB

OCB

参考资料
Reference
data



重复精度
Repeat Accuracy
±0.05 mm

此图仅供参考, 出货规格详见尺寸图面
This picture for reference only, specs details according with the drawing.

最大行程
Max Stroke **4050mm**

最高速度
Max Speed **1280mm/s**

马达容量
Motor Output **750W**

皮带宽度
Belt Width **60mm**

直线滑轨
Linear Guide **30X26-1支**

型号表达方式 Ordering method

TPA-ONB-120-256-L4050-MR-Y-P75B-N3-F

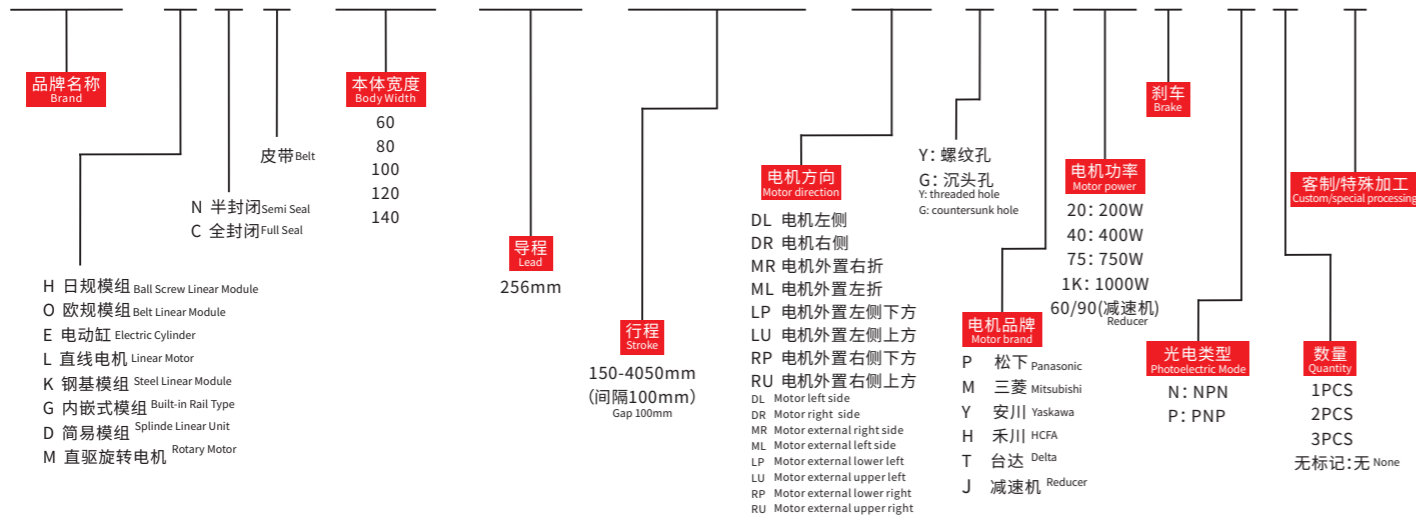

产品性能参数如下 Product performance parameters are as follows

规格 Spec	重复定位精度 (mm) Repeated positioning accuracy (mm)	±0.05		
	马达转速 (rpm/min) Rated Speed (rpm/min)	10:1	15:1	20:1
	最高速度 (mm/s) Maximum speed (mm/s)	1280	852	640
	最大可搬重量 Maximum Payload	水平使用 (kg) Horizontal (kg)	110	160
部品 Parts	垂直使用 (kg) Vertical (kg) ^{※2}	40	50	70
	导程 (mm) lead (mm)	256		
	定格推力 (N) Rated thrust (N)	810		
	标准行程 (mm) Stroke pitch (mm) ^{※3}	150~4050mm/100 间隔 100 mm Pitch		
	AC伺服马达容量 (W) AC servo motor output (w)	750		
部 品 部 分	皮带宽度 (mm) Belt Width (mm)	60		
	高刚性直线滑轨 (mm) High rigidity linear guide (mm)	30X26		
	原点感应器 Home sensor	外挂 Outside	672 (NPN)	

※1 马达加速设定0.4秒。※1 Acceleration and deceleration value is set 0.4 second.
 ※2 垂直使用时,若皮带断裂,承载物会有掉落危险,请留意。
 ※2 Notice, if the belt breaks, the moving parts will fall when the application is vertical.
 ※3 滑台未安装减速机时,导程为110。※3 Lead is 110mm without gearbox.

容许负载力矩表 N.m Allowable overhang

各行程M5后装螺帽数量 M5 nuts Qty.(by stroke)			
有效行程 Stroke	数量 Quantity	有效行程 Stroke	数量 Quantity
100-500	4	2600-3000	14
600-1000	6	3100-3500	16
1100-1500	8	3600-4050	18

※滑台标准固定方式为下锁式,使用M5后装螺帽固定。
 ※Standard mounting method is fix from the bottom, using the M5 bolt and nut.

容许负载力矩表 N.m Allowable overhang

速度比	水平安装 Horizontal installation (单位Unit:mm)				侧面安装 Side mounting (单位Unit:mm)				垂直安装 Vertical installation (单位Unit:mm)			
	A	B	C	重量	A	B	C	重量	A	B	C	重量
10:1	80kg	1118	203	33	80kg	33	203	1118	5kg	1308	1308	
	95kg	758	134	24	95kg	24	134	758	15kg	878	878	
	110kg	558	93	19	110kg	19	93	558	40kg	688	688	
15:1	130kg	1408	168	28	130kg	28	168	1408	20kg	1488	1488	
	145kg	948	108	21	145kg	21	108	948	35kg	838	838	
	160kg	658	71	16	160kg	16	71	658	50kg	583	583	
20:1	180kg	1408	123	23	180kg	23	123	1408	40kg	758	758	
	195kg	908	73	16	195kg	16	73	908	55kg	568	568	
	210kg	558	43	13	210kg	13	43	558	70kg	458	458	

速度-荷重曲线图 Acceleration-payload relationship

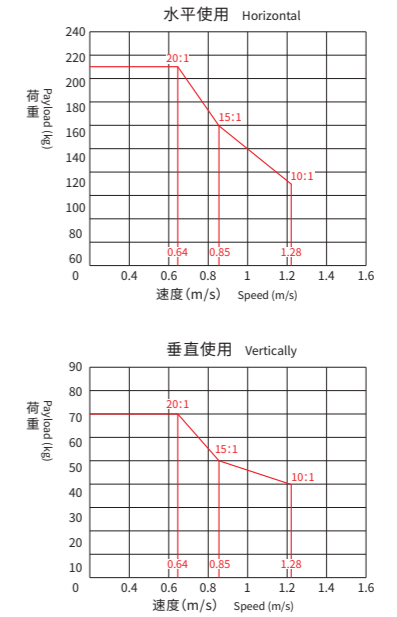

ONB

OCB

参考资料
Reference data

安装示意图 Installation diagram

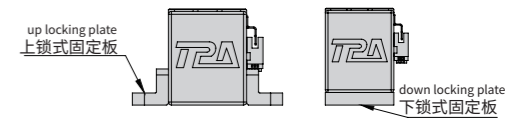

※上锁式固定板非标准品,若有需求请另外追加选购。
 ※Top fixing plate is optional.

静态容许负载惯量 Static loading moment

(单位Unit:N.m)	
MY	1600
MP	1600
MR	400

*力矩表所表示的数据,代表重心。
 The torque value in the chart indicate the center of gravity.
 *符合型录规范的正常试用下,保证寿命为10000公里。
 Operation life is 10,000km when the product is using under the specified conditions.
 *倒吊使用无法套用标准规范,如有需求请咨询我司业务。
 The standard specification cannot be applied to the use of inverted crane.
 Please consult our business if necessary.

电机外置左侧/电机外置右侧
Motor external left side / Motor external right side

ML 电机外置左侧 Motor external left side

单位:Unit: mm

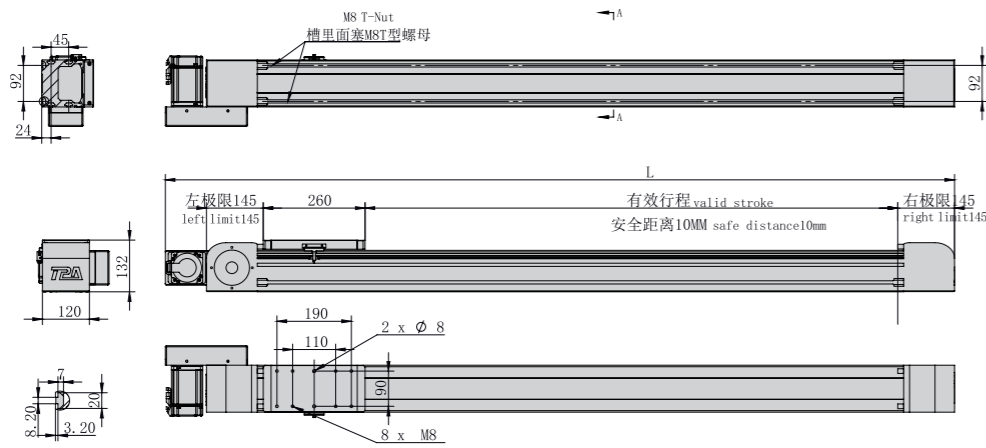

*不含电机和安装板重量 *Excluding motor and mounting plate weight

有效行程 Stroke	150	250	350	450	550	650	750	850	950	1050	1150	1250	1350	1450	1550	1650	1750	1850	1950	2050
L	915	1015	1115	1215	1315	1415	1515	1615	1715	1815	1915	2015	2115	2215	2315	2415	2515	2615	2715	2815
KG	27.8	29.3	30.8	32.3	33.8	35.3	36.8	38.3	39.8	41.3	42.8	44.3	45.8	47.3	48.8	50.3	51.8	53.3	54.8	56.3

有效行程 Stroke	2150	2250	2350	2450	2550	2650	2750	2850	2950	3050	3150	3250	3350	3450	3550	3650	3750	3850	3950	4050
L	2915	3015	3115	3215	3315	3415	3515	3615	3715	3815	3915	4015	4115	4215	4315	4415	4515	4615	4715	4815
KG	57.8	59.3	60.8	62.3	63.8	65.3	66.8	68.3	69.8	71.3	72.8	74.3	75.8	77.3	78.8	80.3	81.8	83.3	84.8	86.3

电机外置左下/电机外置左上
Motor external lower left / Motor external upper left

LP 电机外置左下 Motor external lower left

单位:Unit: mm

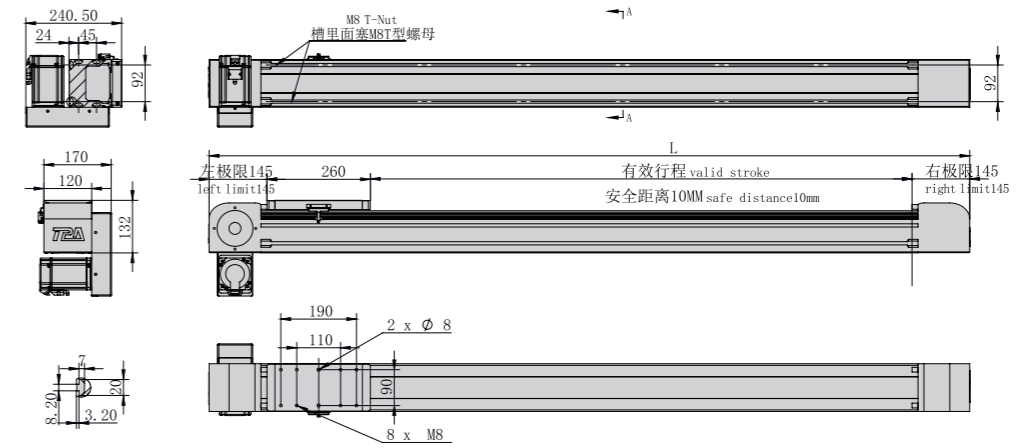

*不含电机和安装板重量 *Excluding motor and mounting plate weight

有效行程 Stroke	150	250	350	450	550	650	750	850	950	1050	1150	1250	1350	1450	1550	1650	1750	1850	1950	2050
L	710	810	910	1010	1110	1210	1310	1410	1510	1610	1710	1810	1910	2010	2110	2210	2310	2410	2510	2610
KG	27.8	29.3	30.8	32.3	33.8	35.3	36.8	38.3	39.8	41.3	42.8	44.3	45.8	47.3	48.8	50.3	51.8	53.3	54.8	56.3

有效行程 Stroke	2150	2250	2350	2450	2550	2650	2750	2850	2950	3050	3150	3250	3350	3450	3550	3650	3750	3850	3950	4050
L	2710	2810	2910	3010	3110	3210	3310	3410	3510	3610	3710	3810	3910	4010	4110	4210	4310	4410	4510	4610
KG	57.8	59.3	60.8	62.3	63.8	65.3	66.8	68.3	69.8	71.3	72.8	74.3	75.8	77.3	78.8	80.3	81.8	83.3	84.8	86.3

电机外置右侧 Motor external right side

MR 电机外置右侧 Motor external right side

单位:Unit: mm

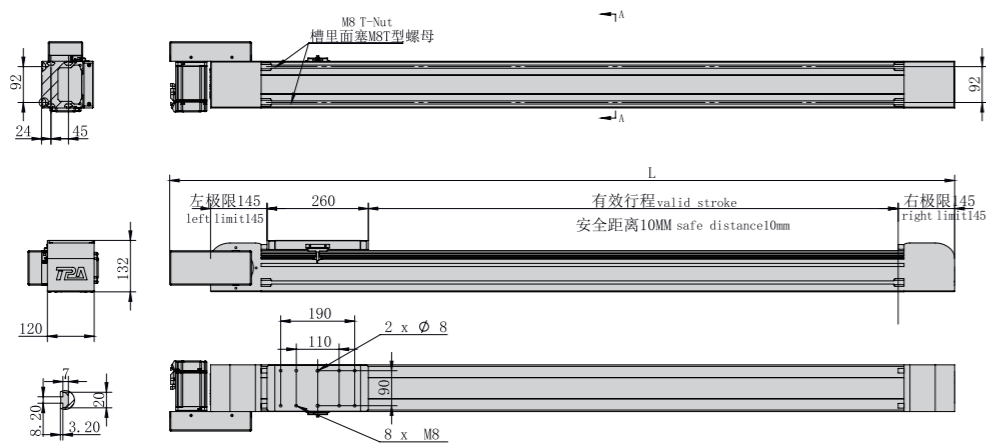

*不含电机和安装板重量 *Excluding motor and mounting plate weight

有效行程 Stroke	150	250	350	450	550	650	750	850	950	1050	1150	1250	1350	1450	1550	1650	1750	1850	1950	2050
L	915	1015	1115	1215	1315	1415	1515	1615	1715	1815	1915	2015	2115	2215	2315	2415	2515	2615	2715	2815
KG	27.8	29.3	30.8	32.3	33.8	35.3	36.8	38.3	39.8	41.3	42.8	44.3	45.8	47.3	48.8	50.3	51.8	53.3	54.8	56.3

有效行程 Stroke	2150	2250	2350	2450	2550	2650	2750	2850	2950	3050	3150	3250	3350	3450	3550	3650	3750	3850	3950	4050
L	2915	3015	3115	3215	3315	3415	3515	3615	3715	3815	3915	4015	4115	4215	4315	4415	4515	4615	4715	4815
KG	57.8	59.3	60.8	62.3	63.8	65.3	66.8	68.3	69.8	71.3	72.8	74.3	75.8	77.3	78.8	80.3	81.8	83.3	84.8	86.3

电机外置左上 Motor external upper left

LU 电机外置左上 Motor external upper left

单位:Unit: mm

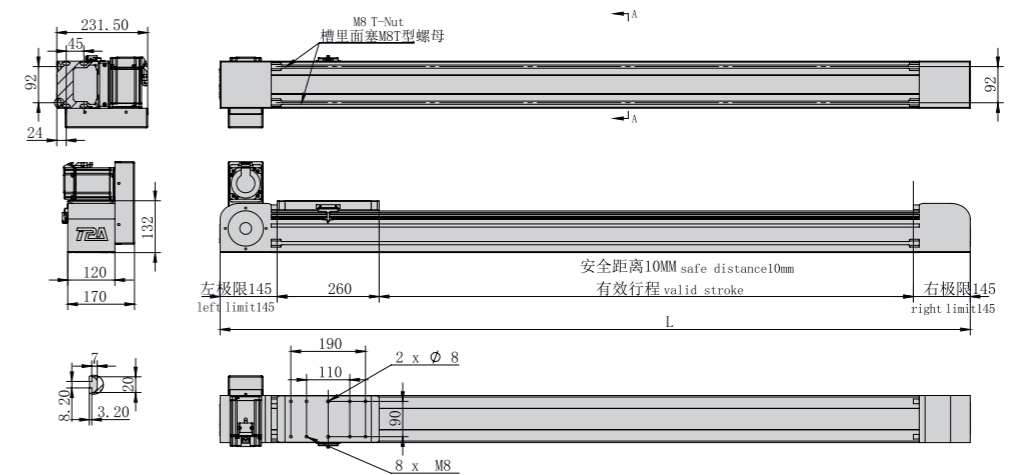

*不含电机和安装板重量 *Excluding motor and mounting plate weight

有效行程 Stroke	150	250	350	450	550	650	750	850	950	1050	1150	1250	1350	1450	1550	1650	1750	1850	1950	2050
L	710	810	910	1010	1110	1210	1310	1410	1510	1610	1710	1810	1910	2010	2110	2210	2310	2410	2510	2610
KG	27.8	29.3	30.8	32.3	33.8	35.3	36.8	38.3	39.8	41.3	42.8	44.3	45.8	47.3	48.8	50.3	51.8	53.3	54.8	56.3

有效行程 Stroke	2150	2250	2350	2450	2550	2650	2750	2850	2950	3050	3150	3250	3350	3450	3550	3650	3750	3850	3950	4050
L	2710	2810	2910	3010	3110	3210	3310	3410	3510	3610	3710	3810	3910	4010	4110	4210	4310	4410	4510	4610
KG	57.8	59.3	60.8	62.3	63.8	65.3	66.8	68.3	69.8	71.3	72.8	74.3	75.8	77.3	78.8	80.3	81.8	83.3	84.8	86.3



电机外置右下/电机外置右上
Motor external lower right / Motor external upper right

RP 电机外置右下 Motor external lower right

单位:Unit: mm

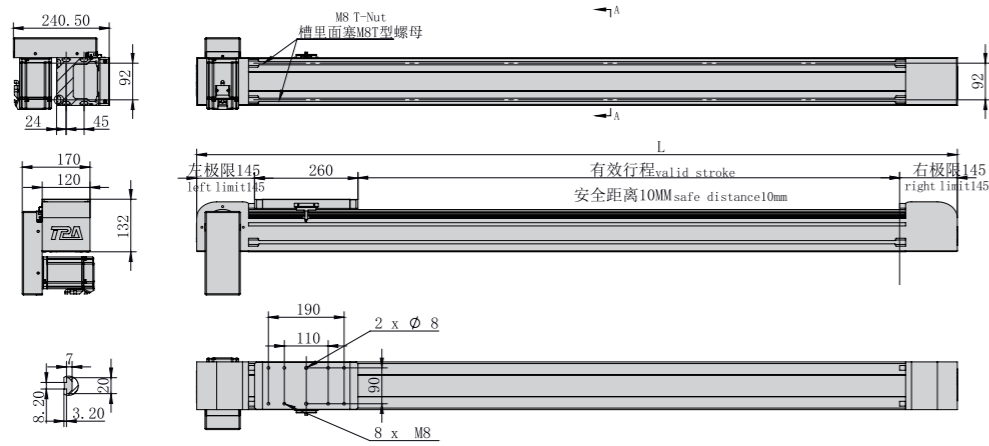

*不含电机和安装板重量 *Excluding motor and mounting plate weight

有效行程 Stroke	150	250	350	450	550	650	750	850	950	1050	1150	1250	1350	1450	1550	1650	1750	1850	1950	2050
L	710	810	910	1010	1110	1210	1310	1410	1510	1610	1710	1810	1910	2010	2110	2210	2310	2410	2510	2610
KG	27.8	29.3	30.8	32.3	33.8	35.3	36.8	38.3	39.8	41.3	42.8	44.3	45.8	47.3	48.8	50.3	51.8	53.3	54.8	56.3

有效行程 Stroke	2150	2250	2350	2450	2550	2650	2750	2850	2950	3050	3150	3250	3350	3450	3550	3650	3750	3850	3950	4050
L	2710	2810	2910	3010	3110	3210	3310	3410	3510	3610	3710	3810	3910	4010	4110	4210	4310	4410	4510	4610
KG	57.8	59.3	60.8	62.3	63.8	65.3	66.8	68.3	69.8	71.3	72.8	74.3	75.8	77.3	78.8	80.3	81.8	83.3	84.8	86.3

RU 电机外置右上 Motor external upper right

单位:Unit: mm

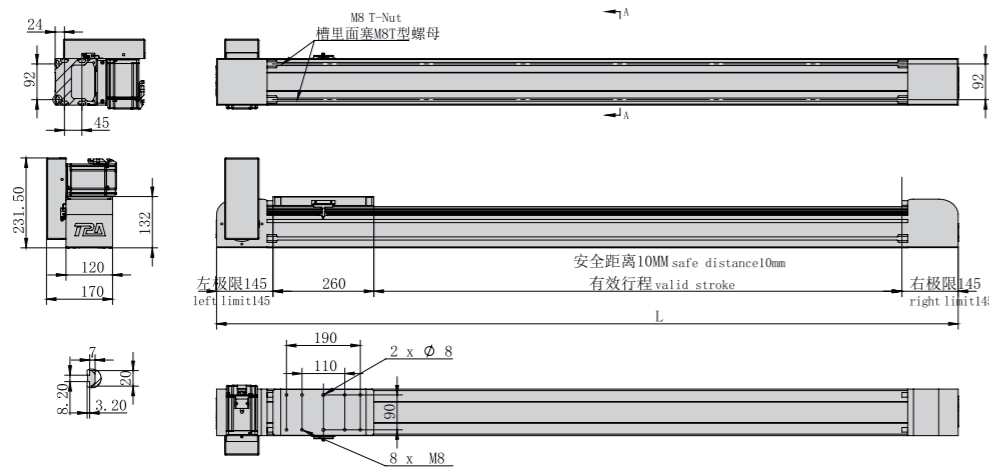

*不含电机和安装板重量 *Excluding motor and mounting plate weight

有效行程 Stroke	150	250	350	450	550	650	750	850	950	1050	1150	1250	1350	1450	1550	1650	1750	1850	1950	2050
L	710	810	910	1010	1110	1210	1310	1410	1510	1610	1710	1810	1910	2010	2110	2210	2310	2410	2510	2610
KG	27.8	29.3	30.8	32.3	33.8	35.3	36.8	38.3	39.8	41.3	42.8	44.3	45.8	47.3	48.8	50.3	51.8	53.3	54.8	56.3

有效行程 Stroke	2150	2250	2350	2450	2550	2650	2750	2850	2950	3050	3150	3250	3350	3450	3550	3650	3750	3850	3950	4050
L	2710	2810	2910	3010	3110	3210	3310	3410	3510	3610	3710	3810	3910	4010	4110	4210	4310	4410	4510	4610
KG	57.8	59.3	60.8	62.3	63.8	65.3	66.8	68.3	69.8	71.3	72.8	74.3	75.8	77.3	78.8	80.3	81.8	83.3	84.8	86.3

MEMO

ONB

OCB

参考资料
Reference
data



重复精度
Repeat Accuracy
±0.05
mm

此图仅供参考, 出货规格详见尺寸图面
This picture for reference only, specs details according with the drawing.

- 最大行程 Max Stroke: 5050mm
- 最高速度 Max Speed: 1280mm/s
- 马达容量 Motor Output: 750W
- 皮带宽度 Belt Width: 78mm
- 直线滑轨 Linear Guide: 30X26-1支

型号表达方式 Ordering method

TPA-ONB-140-256-L5050-MR-Y-P75B-N3-F

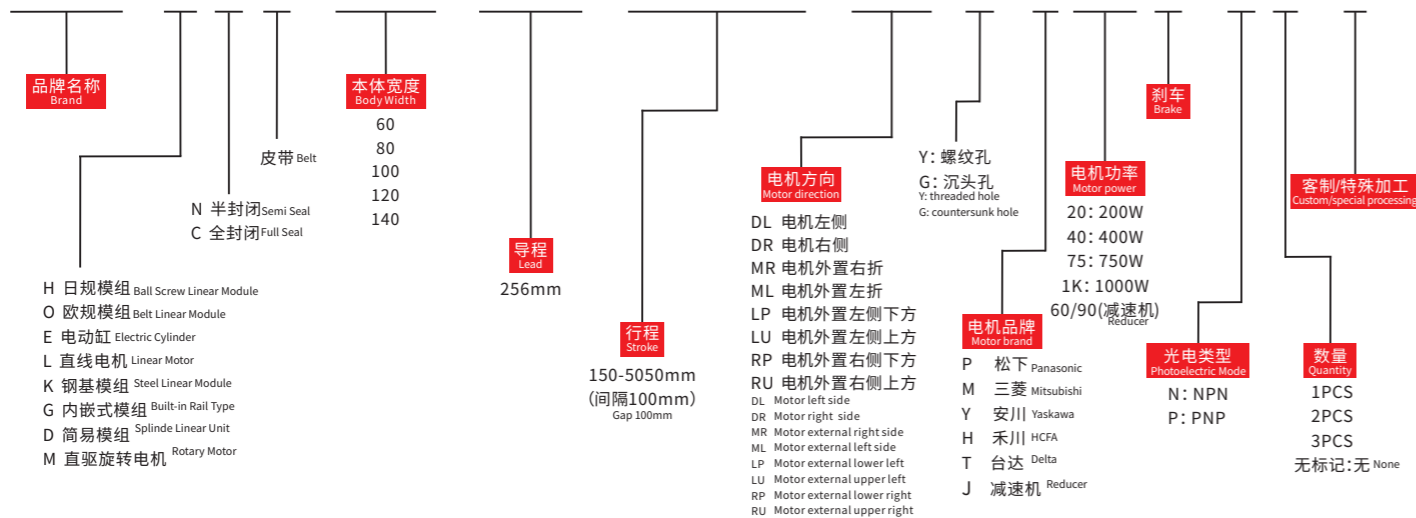

产品性能参数如下 Product performance parameters are as follows

规格 Spec	重复定位精度 (mm) Repeated positioning accuracy (mm)	±0.05		
	马达转速 (rpm/min) Rated Speed (rpm/min)	10:1	15:1	20:1
	最高速度 (mm/s) Maximum speed (mm/s)	1280	853	640
	最大可搬重量 Maximum Payload	水平使用 (kg) Horizontal (kg)	120	170
部品 Parts	垂直使用 (kg) Vertical (kg)	40	60	90
	导程 (mm) lead (mm)	256		
	定格推力 (N) Rated thrust (N)	910		
	标准行程 (mm) Stroke pitch (mm)	150~5050mm/100 间隔 100 mm Pitch		
	AC伺服马达容量 (W) AC servo motor output (w)	750		
皮带宽度 (mm) Belt Width (mm)	78			
高刚性直线滑轨 (mm) High rigidity linear guide (mm)	30X26			
原点感应器 Home sensor	外挂 Outside	672(NPN)		

※1 马达加速设定0.4秒。※1 Acceleration and deceleration value is set 0.4 second.
 ※2 垂直使用时,若皮带断裂,承载物会有掉落危险,请注意。
 ※2 Notice, if the belt breaks, the moving parts will fall when the application is vertical.
 ※3 滑台未安装减速机时,导程为110。※3 Lead is 110mm without gearbox.

容许负载力矩表 N.m Allowable overhang

各行程M5后装螺帽数量 M5 nuts Qty.(by stroke)			
有效行程 Stroke	数量 Quantity	有效行程 Stroke	数量 Quantity
100~500	4	2600~3000	14
600~1000	6	3100~3500	16
1100~1500	8	3600~4000	18
1600~2000	10	4100~4500	20
2100~2500	12	4600~5050	22

※滑台标准固定方式为下锁式,使用M5后装螺帽固定。
 ※Standard mounting method is fix from the bottom, using the M5 bolt and nut.

容许负载力矩表 N.m Allowable overhang

速度比	水平安装 Horizontal installation			侧面安装 Side mounting			垂直安装 Vertical installation				
	A	B	C	A	B	C	A	B	C		
10:1	90kg	618	71	95	90kg	618	71	95	10kg	900	900
	105kg	418	31	45	105kg	418	31	45	25kg	450	450
	120kg	257	12	25	120kg	257	12	25	40kg	300	300
15:1	140kg	570	138	185	140kg	570	138	185	30kg	900	900
	155kg	335	67	85	155kg	335	67	85	45kg	450	450
	170kg	238	40	52	170kg	238	40	52	60kg	300	300
20:1	190kg	304	114	130	190kg	304	114	130	50kg	900	900
	205kg	209	67	80	205kg	209	67	80	65kg	450	450
	230kg	166	52	60	230kg	166	52	60	90kg	300	300

速度-荷重曲线图 Acceleration-payload relationship

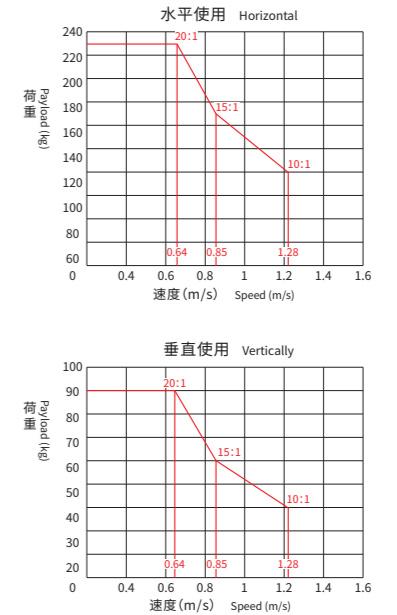

安装示意图 Installation diagram

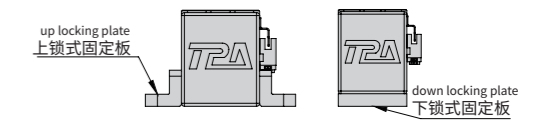

※上锁式固定板非标准品,若有需求请另外追加选购。
 ※Top fixing plate is optional.

静态容许负载惯量 Static loading moment

(单位Unit:N.m)		
MY		1700
MP		1700
MR		500

*力矩表所表示的数据,代表重心。
 The torque value in the chart indicate the center of gravity.
 *符合型录规范的正常试用下,保证寿命为10000公里。
 Operation life is 10,000km when the product is using under the specified conditions.
 *倒吊使用无法套用标准规范,如有需求请咨询我司业务。
 The standard specification cannot be applied to the use of inverted crane.
 Please consult our business if necessary.



电机外置左侧/电机外置右侧
Motor external left side / Motor external right side

ML 电机外置左侧 Motor external left side

单位:Unit: mm

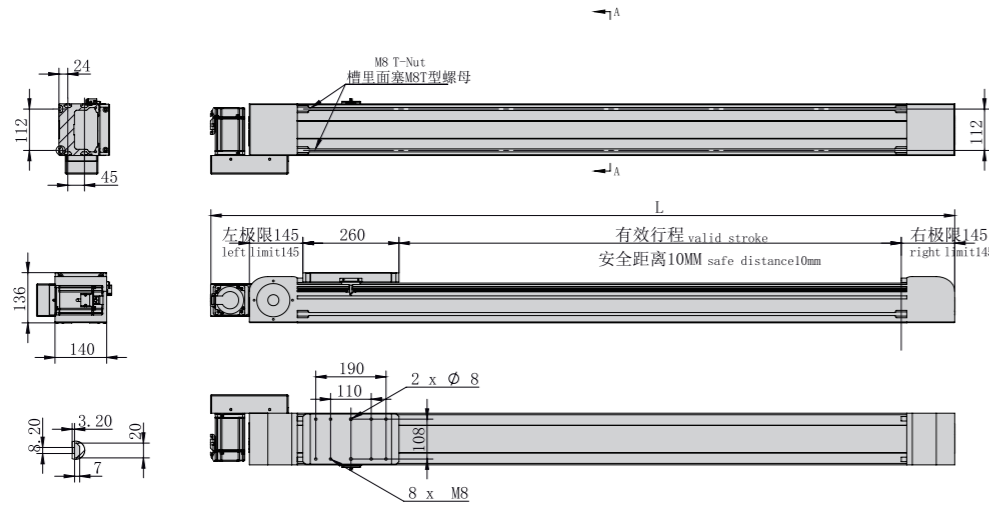

*不含电机和安装板重量 *Excluding motor and mounting plate weight

有效行程 Stroke	150	250	350	450	550	650	750	850	950	1050	1150	1250	1350	1450	1550	1650	1750	1850	1950	2050	2150	2250	2350	2450	2550
L	814	914	1014	1114	1214	1314	1414	1514	1614	1714	1814	1914	2014	2114	2214	2314	2414	2514	2614	2714	2814	2914	3014	3114	3214
KG	26.9	28.7	30.5	32.3	34.1	35.9	37.7	39.5	41.3	43.1	44.9	46.7	48.5	50.3	52.1	53.9	55.7	57.5	59.3	61.1	62.9	64.7	66.5	68.3	70.1

有效行程 Stroke	2650	2750	2850	2950	3050	3150	3250	3350	3450	3550	3650	3750	3850	3950	4050	4150	4250	4350	4450	4550	4650	4750	4850	4950	5050
L	3314	3414	3514	3614	3714	3814	3914	4014	4114	4214	4314	4414	4514	4614	4714	4814	4914	5014	5114	5214	5314	5414	5514	5614	5714
KG	71.9	73.7	75.5	77.3	79.1	80.9	82.7	84.5	86.3	88.1	89.9	91.7	93.5	95.3	97.1	98.9	100.7	102.5	104.3	106.1	107.9	109.7	111.5	113.3	115.1

电机外置左下/电机外置左上
Motor external lower left / Motor external upper left

LP 电机外置左下 Motor external lower left

单位:Unit: mm

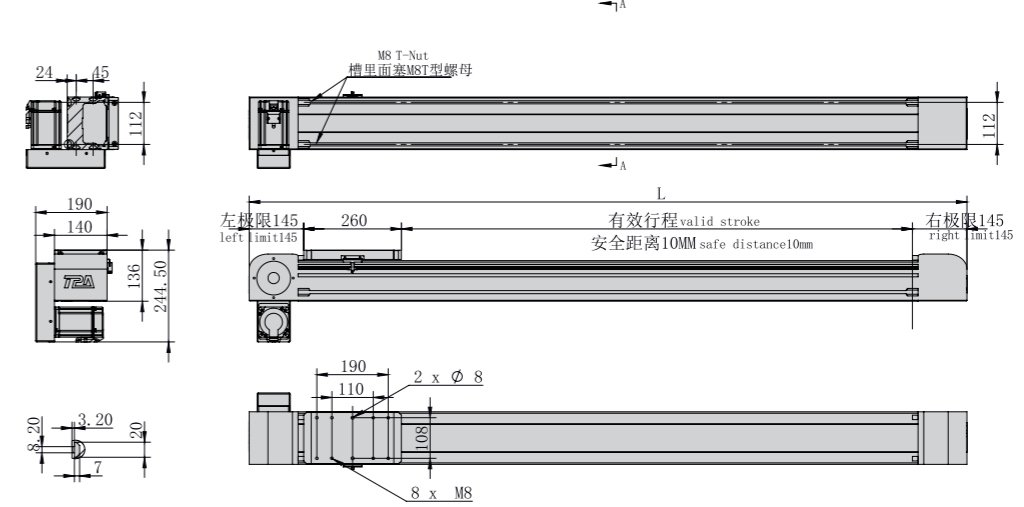

*不含电机和安装板重量 *Excluding motor and mounting plate weight

有效行程 Stroke	150	250	350	450	550	650	750	850	950	1050	1150	1250	1350	1450	1550	1650	1750	1850	1950	2050	2150	2250	2350	2450	2550
L	710	810	910	1010	1110	1210	1310	1410	1510	1610	1710	1810	1910	2010	2110	2210	2310	2410	2510	2610	2710	2810	2910	3010	3110
KG	26.9	28.7	30.5	32.3	34.1	35.9	37.7	39.5	41.3	43.1	44.9	46.7	48.5	50.3	52.1	53.9	55.7	57.5	59.3	61.1	62.9	64.7	66.5	68.3	70.1

有效行程 Stroke	2650	2750	2850	2950	3050	3150	3250	3350	3450	3550	3650	3750	3850	3950	4050	4150	4250	4350	4450	4550	4650	4750	4850	4950	5050
L	3210	3310	3410	3510	3610	3710	3810	3910	4010	4110	4210	4310	4410	4510	4610	4710	4810	4910	5010	5110	5210	5310	5410	5510	5610
KG	71.9	73.7	75.5	77.3	79.1	80.9	82.7	84.5	86.3	88.1	89.9	91.7	93.5	95.3	97.1	98.9	100.7	102.5	104.3	106.1	107.9	109.7	111.5	113.3	115.1

MR 电机外置右侧 Motor external right side

单位:Unit: mm

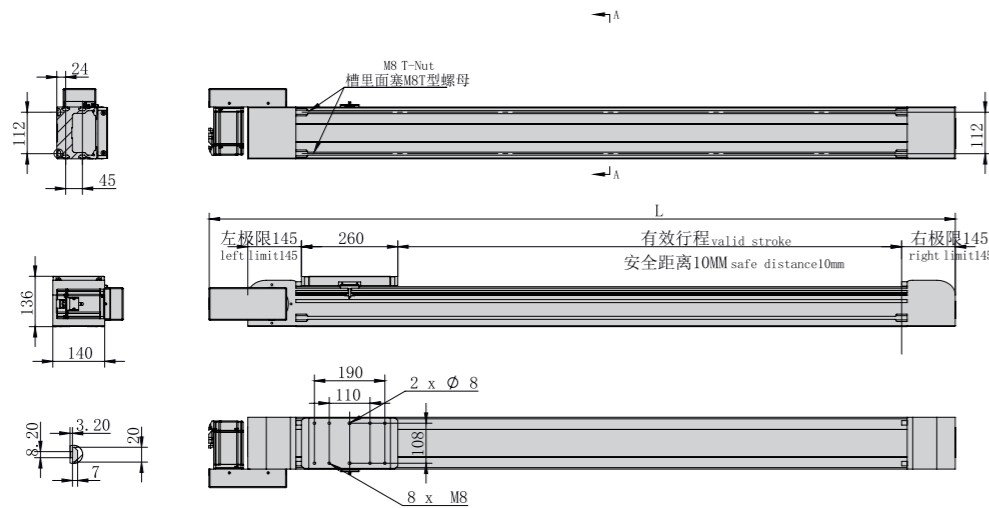

*不含电机和安装板重量 *Excluding motor and mounting plate weight

有效行程 Stroke	150	250	350	450	550	650	750	850	950	1050	1150	1250	1350	1450	1550	1650	1750	1850	1950	2050	2150	2250	2350	2450	2550
L	814	914	1014	1114	1214	1314	1414	1514	1614	1714	1814	1914	2014	2114	2214	2314	2414	2514	2614	2714	2814	2914	3014	3114	3214
KG	26.9	28.7	30.5	32.3	34.1	35.9	37.7	39.5	41.3	43.1	44.9	46.7	48.5	50.3	52.1	53.9	55.7	57.5	59.3	61.1	62.9	64.7	66.5	68.3	70.1

有效行程 Stroke	2650	2750	2850	2950	3050	3150	3250	3350	3450	3550	3650	3750	3850	3950	4050	4150	4250	4350	4450	4550	4650	4750	4850	4950	5050
L	3314	3414	3514	3614	3714	3814	3914	4014	4114	4214	4314	4414	4514	4614	4714	4814	4914	5014	5114	5214	5314	5414	5514	5614	5714
KG	71.9	73.7	75.5	77.3	79.1	80.9	82.7	84.5	86.3	88.1	89.9	91.7	93.5	95.3	97.1	98.9	100.7	102.5	104.3	106.1	107.9	109.7	111.5	113.3	115.1

LU 电机外置左上 Motor external upper left

单位:Unit: mm

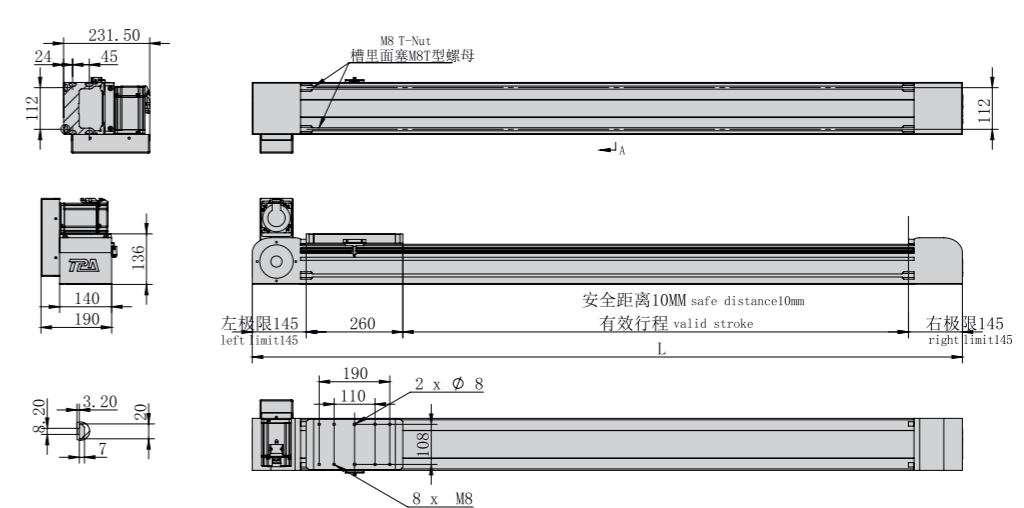

*不含电机和安装板重量 *Excluding motor and mounting plate weight

有效行程 Stroke	150	250	350	450	550	650	750	850	950	1050	1150	1250	1350	1450	1550	1650	1750	1850	1950	2050	2150	2250	2350	2450	2550
L	710	810	910	1010	1110	1210	1310	1410	1510	1610	1710	1810	1910	2010	2110	2210	2310	2410	2510	2610	2710	2810	2910	3010	3110
KG	26.9	28.7	30.5	32.3	34.1	35.9	37.7	39.5	41.3	43.1	44.9	46.7	48.5	50.3	52.1	53.9	55.7	57.5	59.3	61.1	62.9	64.7	66.5	68.3	70.1

有效行程 Stroke	2650	2750	2850	2950	3050	3150	3250	3350	3450	3550	3650	3750	3850	3950	4050	4150	4250	4350	4450	4550	4650	4750	4850	4950	5050
L	3210	3310	3410	3510	3610	3710	3810	3910	4010	4110	4210	4310	4410	4510	4610	4710	4810	4910	5010	5110	5210	5310	5410	5510	5610
KG	71.9	73.7	75.5	77.3	79.1	80.9	82.7	84.5	86.3	88.1	89.9	91.7	93.5	95.3	97.1	98.9	100.7	102.5	104.3	106.1	107.9	109.7	111.5	113.3	115.1



电机外置右下/电机外置右上
Motor external lower right / Motor external upper right

RP 电机外置右下 Motor external lower right

单位:Unit: mm

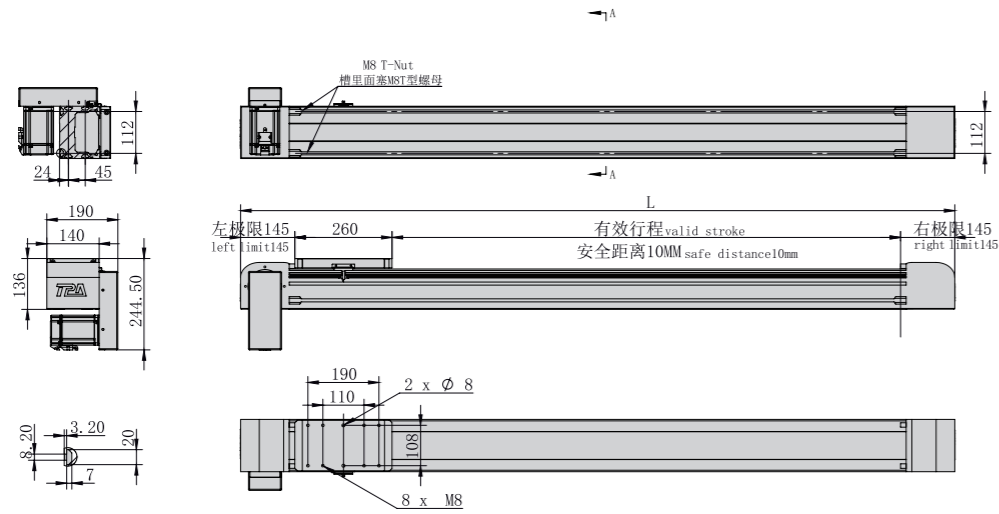

*不含电机和安装板重量 *Excluding motor and mounting plate weight

有效行程 Stroke	150	250	350	450	550	650	750	850	950	1050	1150	1250	1350	1450	1550	1650	1750	1850	1950	2050	2150	2250	2350	2450	2550
L	710	810	910	1010	1110	1210	1310	1410	1510	1610	1710	1810	1910	2010	2110	2210	2310	2410	2510	2610	2710	2810	2910	3010	3110
KG	26.9	28.7	30.5	32.3	34.1	35.9	37.7	39.5	41.3	43.1	44.9	46.7	48.5	50.3	52.1	53.9	55.7	57.5	59.3	61.1	62.9	64.7	66.5	68.3	70.1

有效行程 Stroke	2650	2750	2850	2950	3050	3150	3250	3350	3450	3550	3650	3750	3850	3950	4050	4150	4250	4350	4450	4550	4650	4750	4850	4950	5050
L	3210	3310	3410	3510	3610	3710	3810	3910	4010	4110	4210	4310	4410	4510	4610	4710	4810	4910	5010	5110	5210	5310	5410	5510	5610
KG	71.9	73.7	75.5	77.3	79.1	80.9	82.7	84.5	86.3	88.1	89.9	91.7	93.5	95.3	97.1	98.9	100.7	102.5	104.3	106.1	107.9	109.7	111.5	113.3	115.1

RU 电机外置右上 Motor external upper right

单位:Unit: mm

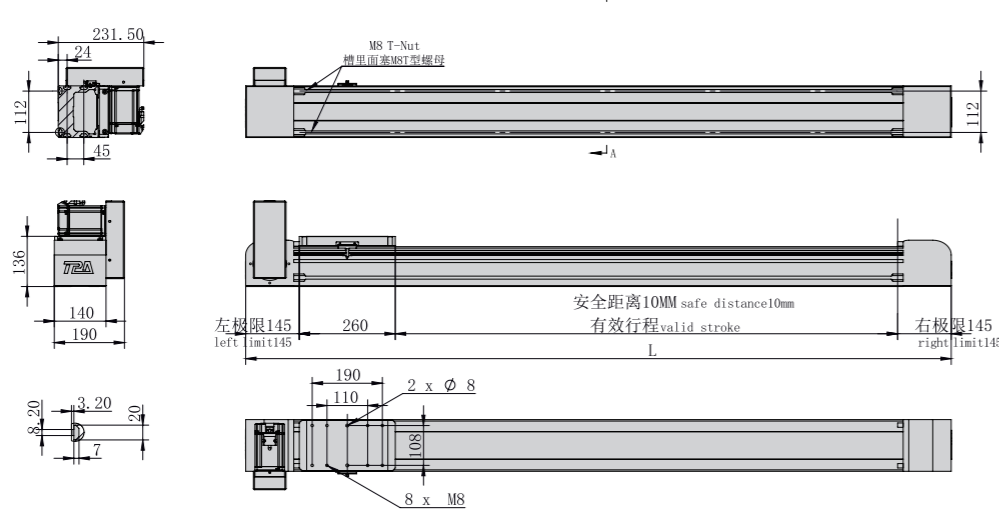

*不含电机和安装板重量 *Excluding motor and mounting plate weight

有效行程 Stroke	150	250	350	450	550	650	750	850	950	1050	1150	1250	1350	1450	1550	1650	1750	1850	1950	2050	2150	2250	2350	2450	2550
L	710	810	910	1010	1110	1210	1310	1410	1510	1610	1710	1810	1910	2010	2110	2210	2310	2410	2510	2610	2710	2810	2910	3010	3110
KG	26.9	28.7	30.5	32.3	34.1	35.9	37.7	39.5	41.3	43.1	44.9	46.7	48.5	50.3	52.1	53.9	55.7	57.5	59.3	61.1	62.9	64.7	66.5	68.3	70.1

有效行程 Stroke	2650	2750	2850	2950	3050	3150	3250	3350	3450	3550	3650	3750	3850	3950	4050	4150	4250	4350	4450	4550	4650	4750	4850	4950	5050
L	3210	3310	3410	3510	3610	3710	3810	3910	4010	4110	4210	4310	4410	4510	4610	4710	4810	4910	5010	5110	5210	5310	5410	5510	5610
KG	71.9	73.7	75.5	77.3	79.1	80.9	82.7	84.5	86.3	88.1	89.9	91.7	93.5	95.3	97.1	98.9	100.7	102.5	104.3	106.1	107.9	109.7	111.5	113.3	115.1

MEMO

ONB

OCB

参考资料
Reference
data



重复精度
Repeat Accuracy
±0.05 mm

此图仅供参考, 出货规格详见尺寸图面
This picture for reference only, specs details according with the drawing.

- 最大行程 Max Stroke: 4050mm
- 最高速度 Max Speed: 4500mm/s
- 马达容量 Motor Output: 750W
- 皮带宽度 Belt Width: 20mm
- 直线滑轨 Linear Guide: 15X12.5-1支

型号表达方式 Ordering method

TPA-ONB-80F-110-L4050-MR-Y-P75B-N3-F

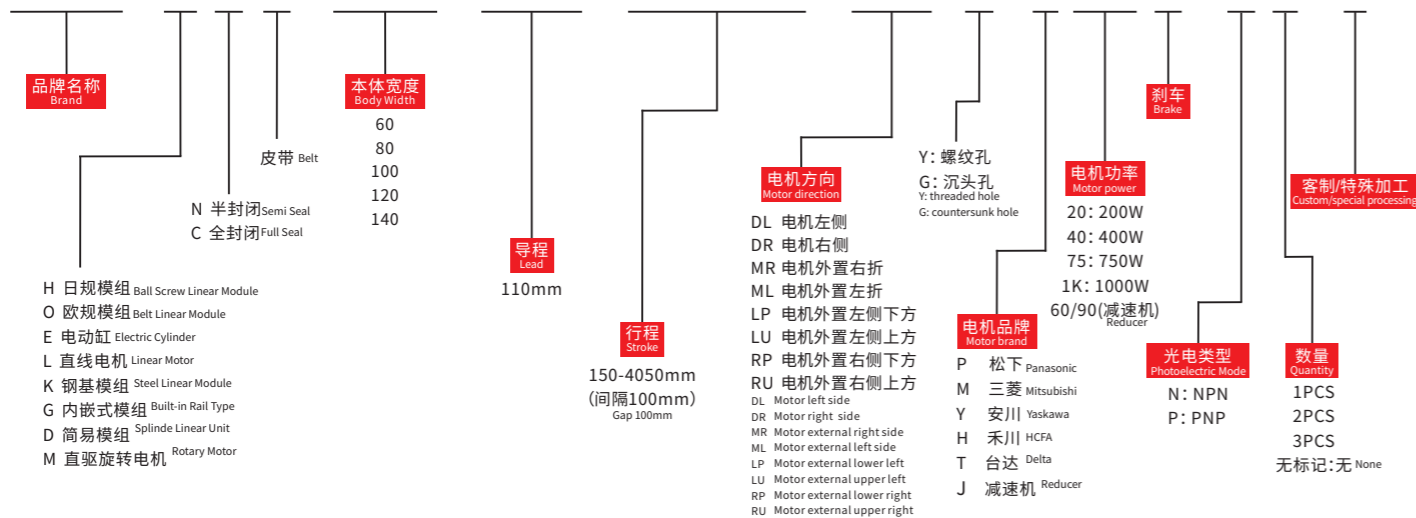

产品性能参数如下 Product performance parameters are as follows

规格 Spec	重复定位精度 (mm) Repeated positioning accuracy (mm)	±0.05					
	马达转速 (rpm/min) Rated Speed (rpm/min)	500	1000	1050	2000	2500	3000
	最高速度 (mm/s) Maximum speed (mm/s)	750	1500	2250	3000	3750	4500
	最大可搬重量 (kg) Maximum Payload	水平使用 (kg) Horizontal (kg)					
部 品 Parts	导程 (mm) lead (mm)	110					
	定格推力 (N) Rated thrust (N)	114					
	标准行程 (mm) Stroke pitch (mm)	150~4050mm/100 间隔 100 mm Pitch					
	AC伺服马达容量 (W) AC servo motor output (w)	750					
	皮带宽度 (mm) Belt Width(mm)	20					
	高刚性直线滑轨 (mm) High rigidity linear guide(mm)	15X12.5					
原点感应器 Home sensor	外挂 Outside	672(NPN)					

※1 马达加减速设定0.4秒。
※1 Acceleration and deceleration value is set 0.4 second.

容许负载力矩表 N.m Allowable overhang

有效行程 Stroke	150-950	150-1450	150-1950	2050-2450	2500-3050
数量 Quantity	6	8	10	12	14

※滑台标准固定方式为下锁式, 使用M5后装螺帽固定。
※Standard mounting method is fix from the bottom, using the M5 bolt and nut.

容许负载力矩表 N.m Allowable overhang



导程 110 Lead	水平安装 Horizontal installation			侧面安装 Side installation		
	重量 Weight	线速度 Speed Maximum	行程 Stroke	重量 Weight	线速度 Speed Maximum	行程 Stroke
110	3kg	4500mm/s	518	61	85	3
	6kg	3750mm/s	418	31	45	6
	10kg	3000mm/s	257	12	25	10
	14kg	2250mm/s	470	138	185	14
	18kg	1500mm/s	235	67	85	18
	26kg	750mm/s	158	40	52	26

搭配伺服马达一览表 Suitable motor brand

品牌 Brand	马达记号 Mark	刹车有无 Brake	马达容量 Motor capacity	电源电压 AC-Voltage	伺服马达型号 Servo motor model	驱动器型号 Driver Model
三菱 Mitsubishi	M	无刹车(水平式样) No brake (horizontal type)	750	220	HG-KR73	MR-J4-70A
松下 Panasonic	P	无刹车(水平式样) No brake (horizontal type)	750	220	MHMD082G1U	MBDHT3520
台达 Delta	T	无刹车(水平式样) No brake (horizontal type)	750	220	ECMA-C20807ES	ASD-B20721-B

速度-荷重曲线图 Acceleration-payload relationship

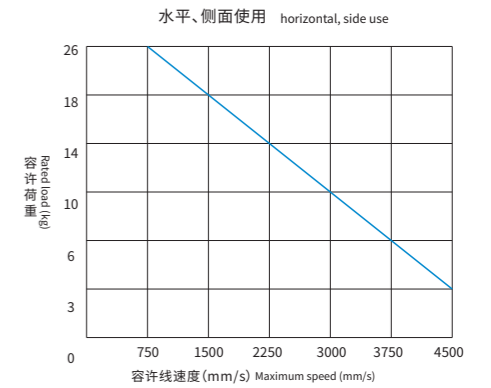

*以上使用条件请参考下方力矩表(最大值不可同时存在)。
*Please refer to the moment diagram below.(Do not reach all maximum value at same time.)

安装示意图 Installation diagram

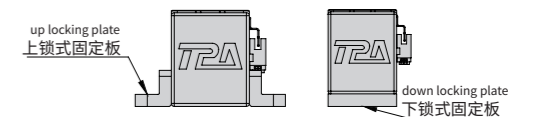

※上锁式固定板非标准品, 若有需求请另追加选购。
※Top fixing plate is optional.

静态容许负载惯量 Static loading moment

配置	静态容许负载惯量 (N.m)
MY	580
MP	580
MR	144

*力矩表所表示的数据, 代表重心。
The torque value in the chart indicate the center of gravity.
*符合型录规范的正常试用下, 保证寿命为10000公里。
Operation life is 10,000km when the product is using under the specified conditions.
*侧吊使用无法套用标准规范, 如有需求请咨询我司业务。
The standard specification cannot be applied to the use of inverted crane.
Please consult our business if necessary.



电机左侧/电机右侧
Motor left side / Motor right side

DL 电机左侧 Motor left side

单位:Unit: mm

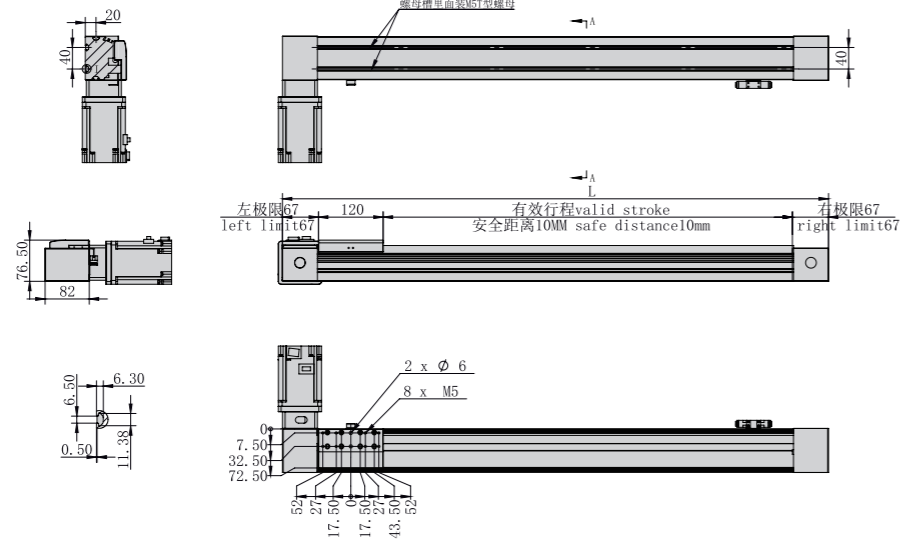

*不含电机和安装板重量 *Excluding motor and mounting plate weight

有效行程 Stroke	150	250	350	450	550	650	750	850	950	1050	1150	1250	1350	1450	1550	1650	1750	1850	1950	2050
L	414	514	614	714	814	914	1014	1114	1214	1314	1414	1514	1614	1714	1814	1914	2014	2114	2214	2314
KG	4.6	5.2	5.8	6.4	7	7.6	8.2	8.8	9.4	10	10.6	11.2	11.8	12.4	13	13.6	14.2	14.8	15.4	16

有效行程 Stroke	2150	2250	2350	2450	2550	2650	2750	2850	2950	3050	3150	3250	3350	3450	3550	3650	3750	3850	3950	4050
L	2414	2514	2614	2714	2814	2914	3014	3114	3214	3314	3414	3514	3614	3714	3814	3914	4014	4114	4214	4314
KG	16.6	17.2	17.8	18.4	19	19.6	20.2	20.8	21.4	22	22.6	23.2	23.8	24.4	25	25.6	26.2	26.8	27.4	28

DR 电机右侧 Motor right side

单位:Unit: mm

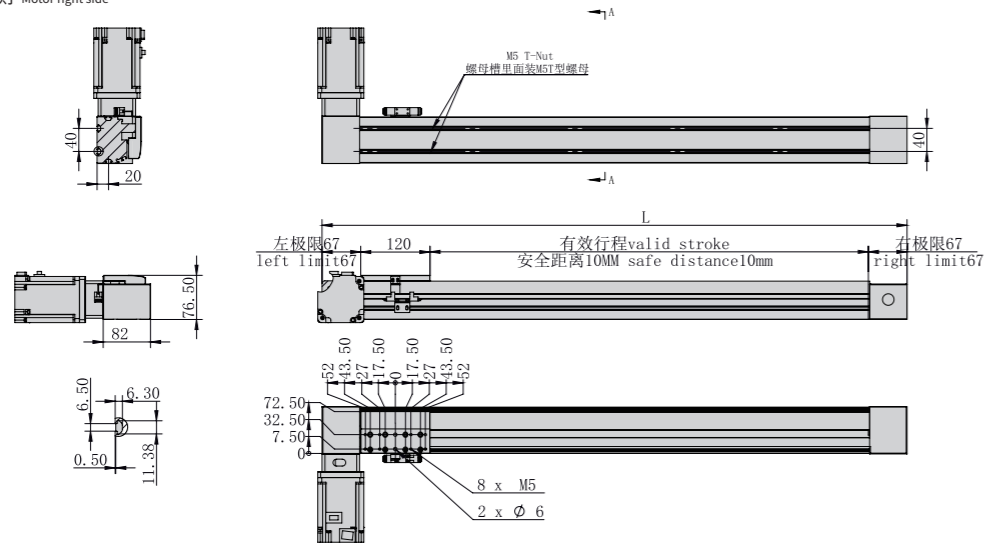

*不含电机和安装板重量 *Excluding motor and mounting plate weight

有效行程 Stroke	150	250	350	450	550	650	750	850	950	1050	1150	1250	1350	1450	1550	1650	1750	1850	1950	2050
L	414	514	614	714	814	914	1014	1114	1214	1314	1414	1514	1614	1714	1814	1914	2014	2114	2214	2314
KG	4.6	5.2	5.8	6.4	7	7.6	8.2	8.8	9.4	10	10.6	11.2	11.8	12.4	13	13.6	14.2	14.8	15.4	16

有效行程 Stroke	2150	2250	2350	2450	2550	2650	2750	2850	2950	3050	3150	3250	3350	3450	3550	3650	3750	3850	3950	4050
L	2414	2514	2614	2714	2814	2914	3014	3114	3214	3314	3414	3514	3614	3714	3814	3914	4014	4114	4214	4314
KG	16.6	17.2	17.8	18.4	19	19.6	20.2	20.8	21.4	22	22.6	23.2	23.8	24.4	25	25.6	26.2	26.8	27.4	28

MEMO

ONB

OCB

参考资料
Reference
data



重复精度
Repeat Accuracy
±0.05 mm

此图仅供参考, 出货规格详见尺寸图面
This picture for reference only, specs details according with the drawing.

- 最大行程 Max Stroke: 3050mm
- 最高速度 Max Speed: 4500mm/s
- 马达容量 Motor Output: 750W
- 皮带宽度 Belt Width: 30mm
- 直线滑轨 Linear Guide: 30X26-1支

型号表达方式 Ordering method

TPA-ONB-120F-90-L3050-MR-Y-P75B-N3-F

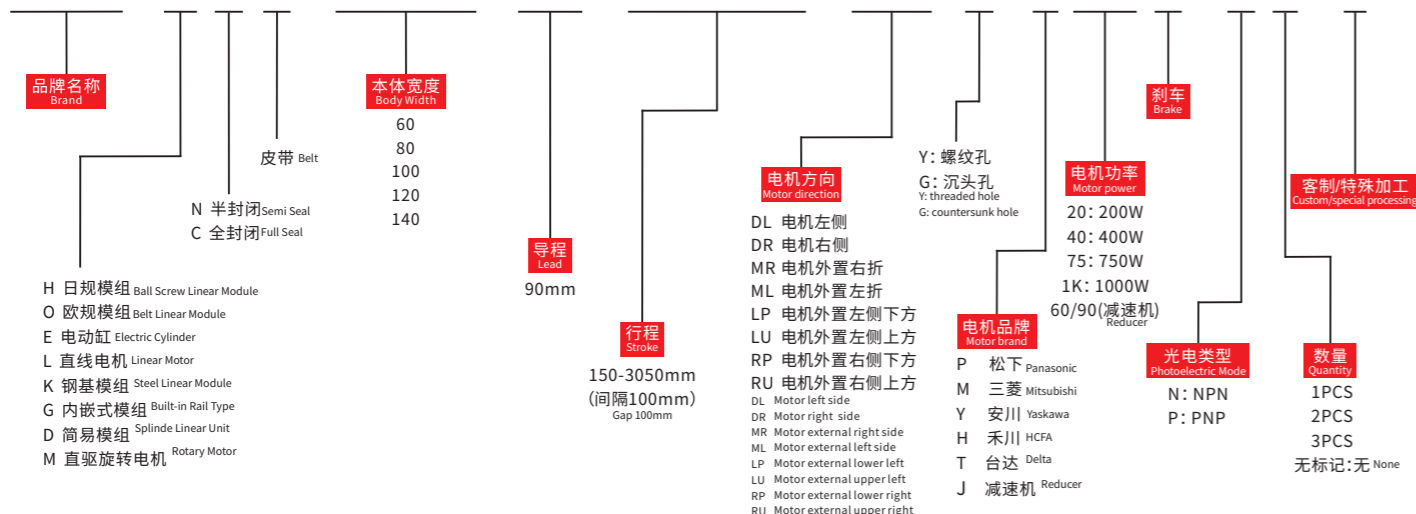

产品性能参数如下 Product performance parameters are as follows

规格 Spec	重复定位精度 (mm) Repeated positioning accuracy (mm)	±0.05					
	马达转速 (rpm/min) Rated Speed (rpm/min)	500	1000	1050	2000	2500	3000
	最高速度 (mm/s) Maximum speed (mm/s)	750	1500	2250	3000	3750	4500
	最大可搬重量 Maximum Payload	水平使用 (kg) Horizontal (kg)					
部品 Parts	导程 (mm) lead (mm)	90					
	定格推力 (N) Rated thrust (N)	134					
	标准行程 (mm) Stroke pitch (mm)	150~3050mm/100 间隔 100 mm Pitch					
	AC伺服马达容量 (W) AC servo motor output (w)	750					
	皮带宽度 (mm) Belt Width (mm)	30					
	高刚性直线滑轨 (mm) High rigidity linear guide (mm)	30X26					
原 点 感 应 器 Home sensor	外 挂 Outside	672 (NPN)					

※1 马达加减速设定0.4秒。
※1 Acceleration and deceleration value is set 0.4 second.

容许负载力矩表 N.m Allowable overhang

各行程M5后装螺帽数量 M5 nuts Qty.(by stroke)		150~950	150~1450	150~1950	2050~2450	2500~3050
有效行程 Stroke	数量 Quantity	6	8	10	12	14

※滑台标准固定方式为下锁式, 使用M5后装螺帽固定。
※Standard mounting method is fix from the bottom, using the M5 bolt and nut.

容许负载力矩表 N.m Allowable overhang



水平安装 Horizontal installation		线速度 Speed Maximum	A	B	C	侧面安装 Horizontal installation		线速度 Speed Maximum	A	B	C
导程 90 Lead	3kg	4500mm/s	618	71	95	导程 90 Lead	3kg	4500mm/s	618	71	95
	6kg	3750mm/s	418	31	45		6kg	3750mm/s	418	31	45
	10kg	3000mm/s	257	12	25		10kg	3000mm/s	257	12	25
	18kg	2250mm/s	570	138	185		18kg	2250mm/s	570	138	185
	26kg	1500mm/s	335	67	85		26kg	1500mm/s	335	67	85
	32kg	750mm/s	238	40	52		32kg	750mm/s	238	40	52

搭配伺服马达一览表 Suitable motor brand

品牌 Brand	马达记号 Mark	刹车有无 Brake	马达容量 Motor capacity	电源电压 AC-Voltage	伺服马达型号 Servo motor model	驱动器型号 Driver Model
三菱 Mitsubishi	M	无刹车(水平式样) No brake (horizontal type)	750	220	HG-KR73	MR-J4-70A
松下 Panasonic	P	无刹车(水平式样) No brake (horizontal type)	750	220	MHMD082G1U	MBDHT3520
台达 Delta	T	无刹车(水平式样) No brake (horizontal type)	750	220	ECMA-C20807ES	ASD-B20721-B

速度-荷重曲线图 Acceleration-payload relationship

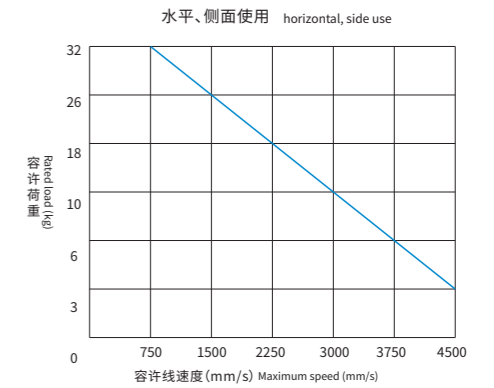

*以上使用条件请参考下方力矩表(最大值不可同时存在)。
*Please refer to the moment diagram below.(Do not reach all maximum value at same time.)

安装示意图 Installation diagram

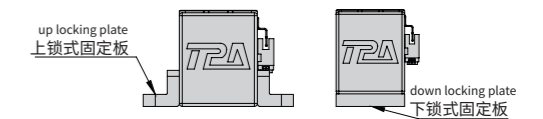

※上锁式固定板非标准品, 若有需求请另外追加选购。
※Top fixing plate is optional.

静态容许负载惯量 Static loading moment

MY	MP	MR
680	680	144

*力矩表所表示的数据, 代表重心。
The torque value in the chart indicate the center of gravity.
*符合型录规范的正常试用下, 保证寿命为10000公里。
Operation life is 10,000km when the product is using under the specified conditions.
*侧吊使用无法套用标准规范, 如有需求请咨询我司业务。
The standard specification cannot be applied to the use of inverted crane.
Please consult our business if necessary.



电机左侧/电机右侧
Motor left side / Motor right side

DL 电机左侧 Motor left side

单位:Unit: mm

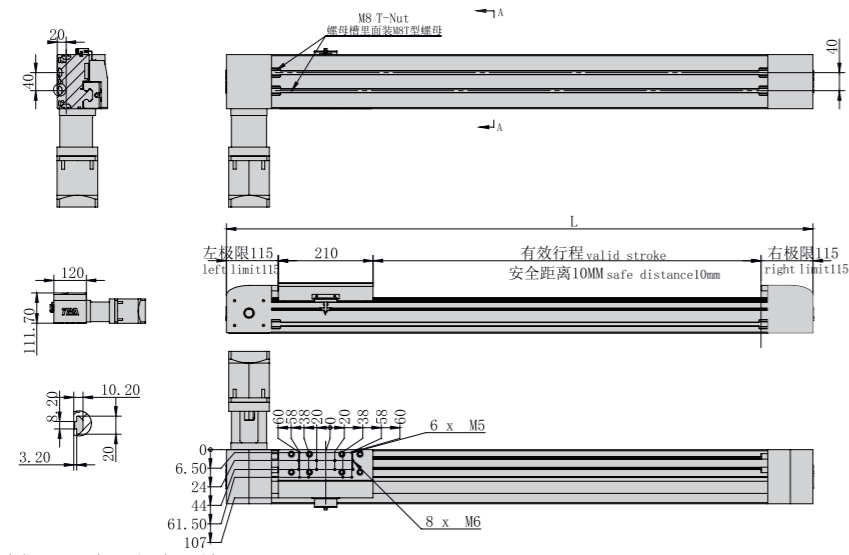

*不含电机和安装板重量 *Excluding motor and mounting plate weight

有效行程 Stroke	150	250	350	450	550	650	750	850	950	1050	1150	1250	1350	1450	1550	1650	1750	1850	1950	2050
L	600	700	800	900	1000	1100	1200	1300	1400	1500	1600	1700	1800	1900	2000	2100	2200	2300	2400	2500
KG	14.4	15.8	17.2	18.6	20	21.4	22.8	24.2	25.6	27	28.4	29.8	31.2	32.6	34	35.4	36.8	38.2	39.6	41

有效行程 Stroke	2150	2250	2350	2450	2550	2650	2750	2850	2950	3050	3150	3250	3350	3450	3550	3650	3750	3850	3950	4050
L	2600	2700	2800	2900	3000	3100	3200	3300	3400	3500	3600	3700	3800	3900	4000	4100	4200	4300	4400	4500
KG	42.4	43.8	45.2	46.6	48	49.4	50.8	52.2	53.6	55	56.4	57.8	59.2	60.6	62	63.4	64.8	66.2	67.6	69

DR 电机右侧 Motor right side

单位:Unit: mm

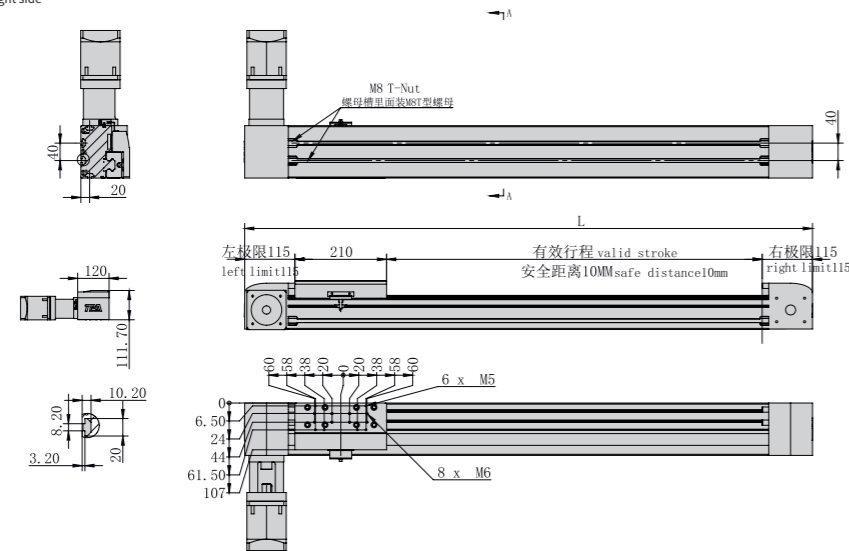

*不含电机和安装板重量 *Excluding motor and mounting plate weight

有效行程 Stroke	150	250	350	450	550	650	750	850	950	1050	1150	1250	1350	1450	1550	1650	1750	1850	1950	2050
L	600	700	800	900	1000	1100	1200	1300	1400	1500	1600	1700	1800	1900	2000	2100	2200	2300	2400	2500
KG	14.4	15.8	17.2	18.6	20	21.4	22.8	24.2	25.6	27	28.4	29.8	31.2	32.6	34	35.4	36.8	38.2	39.6	41

有效行程 Stroke	2150	2250	2350	2450	2550	2650	2750	2850	2950	3050	3150	3250	3350	3450	3550	3650	3750	3850	3950	4050
L	2600	2700	2800	2900	3000	3100	3200	3300	3400	3500	3600	3700	3800	3900	4000	4100	4200	4300	4400	4500
KG	42.4	43.8	45.2	46.6	48	49.4	50.8	52.2	53.6	55	56.4	57.8	59.2	60.6	62	63.4	64.8	66.2	67.6	69

MEMO

ONB

OCB

参考资料
Reference
data



此图仅供参考, 出货规格详见尺寸图面
This picture for reference only, specs details according with the drawing.

最大行程 Max Stroke	3050mm	最高速度 Max Speed	7000mm/s	马达容量 Motor Output	400W	皮带宽度 Belt Width	25mm	直线滑轨 Linear Guide	15X12.5-1支
--------------------	--------	-------------------	----------	----------------------	------	--------------------	------	----------------------	------------

型号表达方式 Ordering method

TPA-OCB-60-140-L3050-DL-Y-P40B-N3-F

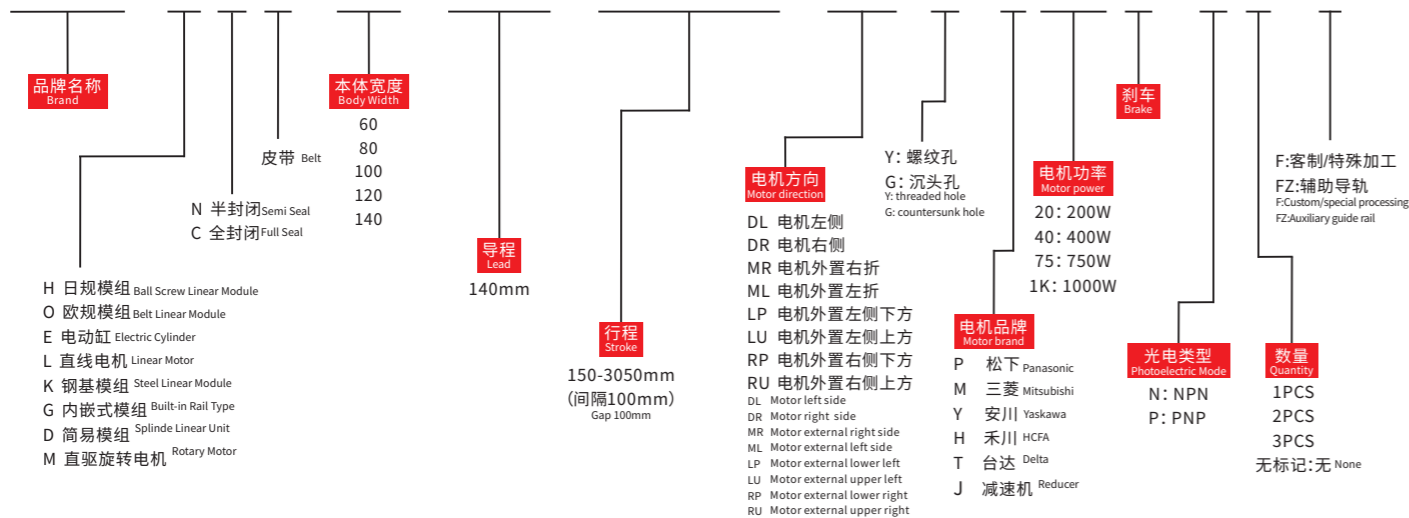

产品性能参数如下 Product performance parameters are as follows

规格 Spec	重复定位精度 (mm) Repeated positioning accuracy (mm)	±0.05					
	马达转速 (rpm/min) Rated Speed (rpm/min)	500	1000	1050	2000	2500	3000
	最高速度 (mm/s) Maximum speed (mm/s)	1160	2300	3500	5600	5800	7000
	最大可搬重量 Maximum Payload	水平使用 (kg) Horizontal (kg)					
部品 Parts	导程 (mm) lead (mm)	140					
	定格推力 (N) Rated thrust (N)	92					
	标准行程 (mm) Stroke pitch (mm)	150~3050mm/100 间隔 100 mm Pitch					
	AC伺服马达容量 (W) AC servo motor output (w)	400					
	皮带宽度 (mm) Belt Width (mm)	25					
	高刚性直线滑轨 (mm) High rigidity linear guide (mm)	15X12.5					
原点感应器 Home sensor	外挂 Outside	672 (NPN)					

※1 马达加减速设定0.4秒。
※1 Acceleration and deceleration value is set 0.4 second.

容许负载力矩表 N.m Allowable overhang

有效行程 Stroke	150-950	150-1450	150-1950	2050-2450	2500-3050
数量 Quantity	6	8	10	12	14

※滑台标准固定方式为下锁式, 使用M5后装螺帽固定。
※Standard mounting method is fix from the bottom, using the M5 bolt and nut.

容许负载力矩表 N.m Allowable overhang



水平安装 Horizontal installation				侧面安装 Side installation			
重量 Weight	线速度 Speed Maximum	A	B	重量 Weight	线速度 Speed Maximum	A	B
2kg	7000mm/s	143	75	25	25	75	143
3kg	5800mm/s	143	50	18	18	50	143
4kg	5600mm/s	145	33	15	15	33	145
8kg	3500mm/s	167	23	12	12	23	167
12kg	2300mm/s	215	22	12	12	22	215
15kg	1160mm/s	215	17	12	12	17	215

搭配伺服马达一览表 Suitable motor brand

品牌 Brand	马达记号 Mark	刹车有无 Brake	马达容量 Motor capacity	电源电压 AC-Voltage	伺服马达型号 Servo motor model	驱动器型号 Driver Model
三菱 Mitsubishi	M	无刹车(水平式样) No brake (horizontal type)	400	220	HG-KR43	MR-J4-40A
松下 Panasonic	P	无刹车(水平式样) No brake (horizontal type)	400	220	MHMD042G1U	MBDHT2510
台达 Delta	T	无刹车(水平式样) No brake (horizontal type)	400	220	ECMA-C20604ES	ASD-B20421-B

速度-荷重曲线图 Acceleration-payload relationship

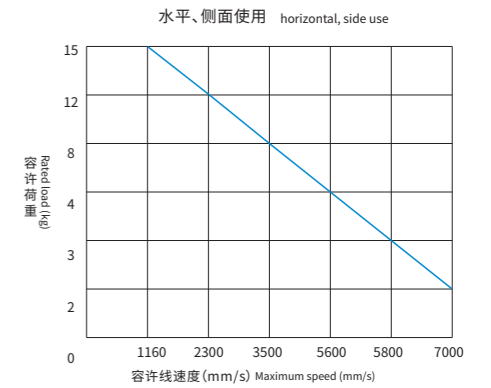

※以上使用条件请参考下方力矩表(最大值不可同时存在)。
※Please refer to the moment diagram below. (Do not reach all maximum value at same time.)

安装示意图 Installation diagram

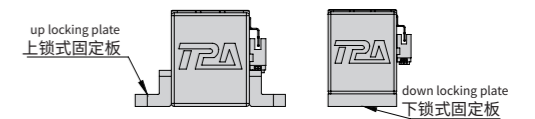

※上锁式固定板非标准品, 若有需求请另外追加选购。
※Top fixing plate is optional.

静态容许负载惯量 Static loading moment

配置	静态容许负载惯量 (N.m)
MY	44
MP	44
MR	12

※力矩表所表示的数据, 代表重心。
The torque value in the chart indicate the center of gravity.
※符合型录规范的正常试用下, 保证寿命为10000公里。
Operation life is 10,000km when the product is using under the specified conditions.
※吊钩使用无法套用标准规范, 如有需求请咨询我司业务。
The standard specification cannot be applied to the use of inverted crane.
Please consult our business if necessary.



电机左侧/电机右侧
Motor left side / Motor right side

DL 电机左侧 Motor left side

单位:Unit: mm

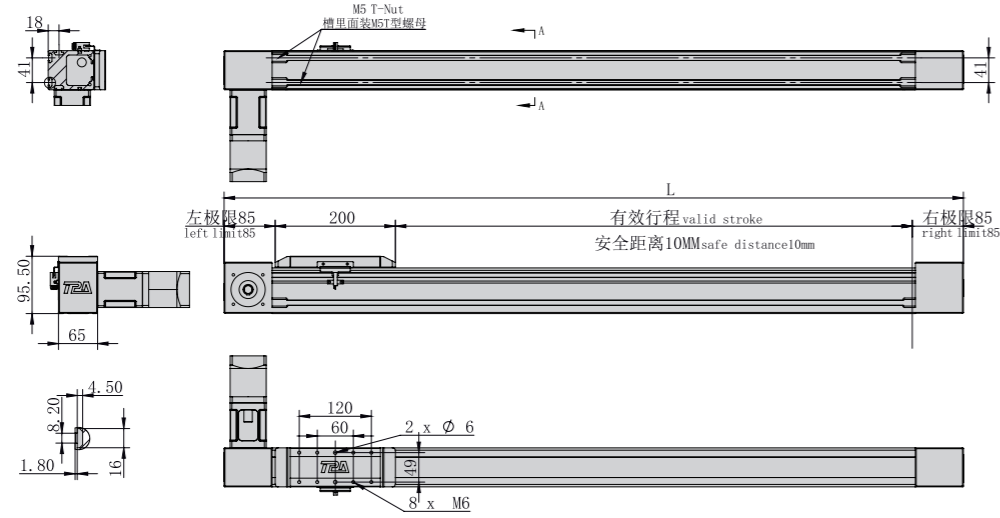

*不含电机和安装板重量 *Excluding motor and mounting plate weight

有效行程 Stroke	150	250	350	450	550	650	750	850	950	1050	1150	1250	1350	1450	1550
L	530	630	730	830	930	1030	1130	1230	1330	1430	1530	1630	1730	1830	1930
KG	7.1	7.6	8.1	8.6	9.1	9.6	10.1	10.6	11.1	11.6	12.1	12.6	13.1	13.6	14.1

有效行程 Stroke	1650	1750	1850	1950	2050	2150	2250	2350	2450	2550	2650	2750	2850	2950	3050
L	2030	2130	2230	2330	2430	2530	2630	2730	2830	2930	3030	3130	3230	3330	3430
KG	14.6	15.1	15.6	16.1	16.6	17.1	17.6	18.1	18.6	19.1	19.6	20.1	20.6	21.1	21.6

OCB60-FZ 辅助导轨
OCB60-FZ Auxiliary guide rail

DL 电机左侧 Motor left side

单位:Unit: mm

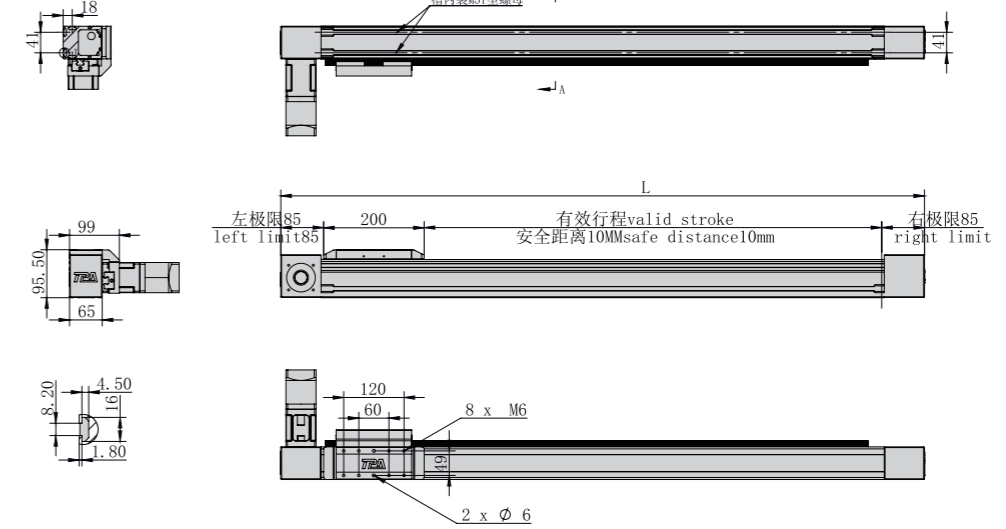

*不含电机和安装板重量 *Excluding motor and mounting plate weight

有效行程 Stroke	150	250	350	450	550	650	750	850	950	1050	1150	1250	1350	1450	1550
L	530	630	730	830	930	1030	1130	1230	1330	1430	1530	1630	1730	1830	1930
KG	8.2	8.8	9.4	10	10.6	11.2	11.8	12.4	13	13.6	14.2	14.8	15.4	16	16.6

有效行程 Stroke	1650	1750	1850	1950	2050	2150	2250	2350	2450	2550	2650	2750	2850	2950	3050
L	2030	2130	2230	2330	2430	2530	2630	2730	2830	2930	3030	3130	3230	3330	3430
KG	17.2	17.8	18.4	19	19.6	20.2	20.8	21.4	22	22.6	23.2	23.8	24.4	25	25.6

DR 电机右侧 Motor right side

单位:Unit: mm

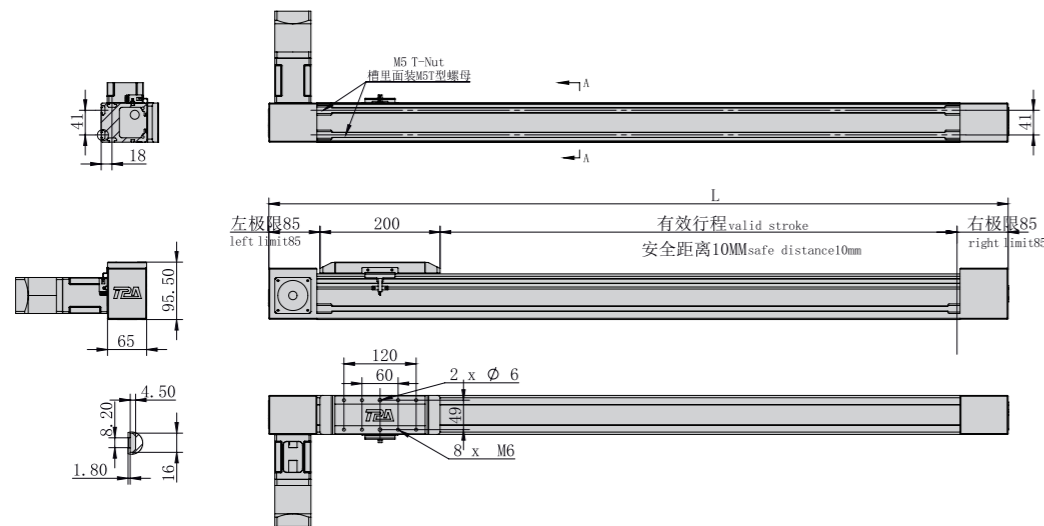

*不含电机和安装板重量 *Excluding motor and mounting plate weight

有效行程 Stroke	150	250	350	450	550	650	750	850	950	1050	1150	1250	1350	1450	1550
L	530	630	730	830	930	1030	1130	1230	1330	1430	1530	1630	1730	1830	1930
KG	7.1	7.6	8.1	8.6	9.1	9.6	10.1	10.6	11.1	11.6	12.1	12.6	13.1	13.6	14.1

有效行程 Stroke	1650	1750	1850	1950	2050	2150	2250	2350	2450	2550	2650	2750	2850	2950	3050
L	2030	2130	2230	2330	2430	2530	2630	2730	2830	2930	3030	3130	3230	3330	3430
KG	14.6	15.1	15.6	16.1	16.6	17.1	17.6	18.1	18.6	19.1	19.6	20.1	20.6	21.1	21.6

DR 电机右侧 Motor right side

单位:Unit: mm

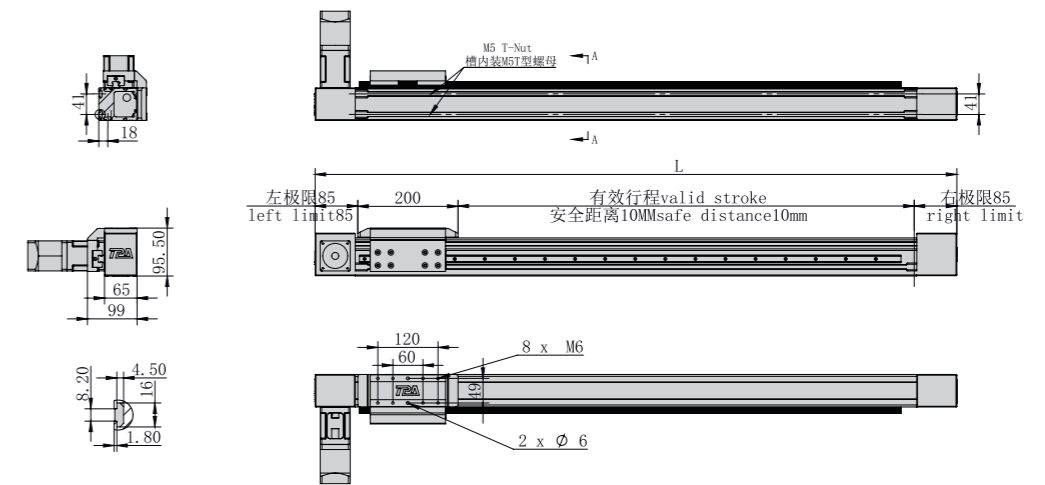

*不含电机和安装板重量 *Excluding motor and mounting plate weight

有效行程 Stroke	150	250	350	450	550	650	750	850	950	1050	1150	1250	1350	1450	1550
L	530	630	730	830	930	1030	1130	1230	1330	1430	1530	1630	1730	1830	1930
KG	8.2	8.8	9.4	10	10.6	11.2	11.8	12.4	13	13.6	14.2	14.8	15.4	16	16.6

有效行程 Stroke	1650	1750	1850	1950	2050	2150	2250	2350	2450	2550	2650	2750	2850	2950	3050
L	2030	2130	2230	2330	2430	2530	2630	2730	2830	2930	3030	3130	3230	3330	3430
KG	17.2	17.8	18.4	19	19.6	20.2	20.8	21.4	22	22.6	23.2	23.8	24.4	25	25.6



重复精度
Repeat Accuracy
±0.05 mm

此图仅供参考, 出货规格详见尺寸图面
This picture for reference only, specs details according with the drawing.

- 最大行程 Max Stroke: 3050mm
- 最高速度 Max Speed: 5000mm/s
- 马达容量 Motor Output: 400W
- 皮带宽度 Belt Width: 30mm
- 直线滑轨 Linear Guide: 20X17.5-1支

型号表达方式 Ordering method

TPA-OCB-80-140-L3050-DL-Y-P40B-N3-F

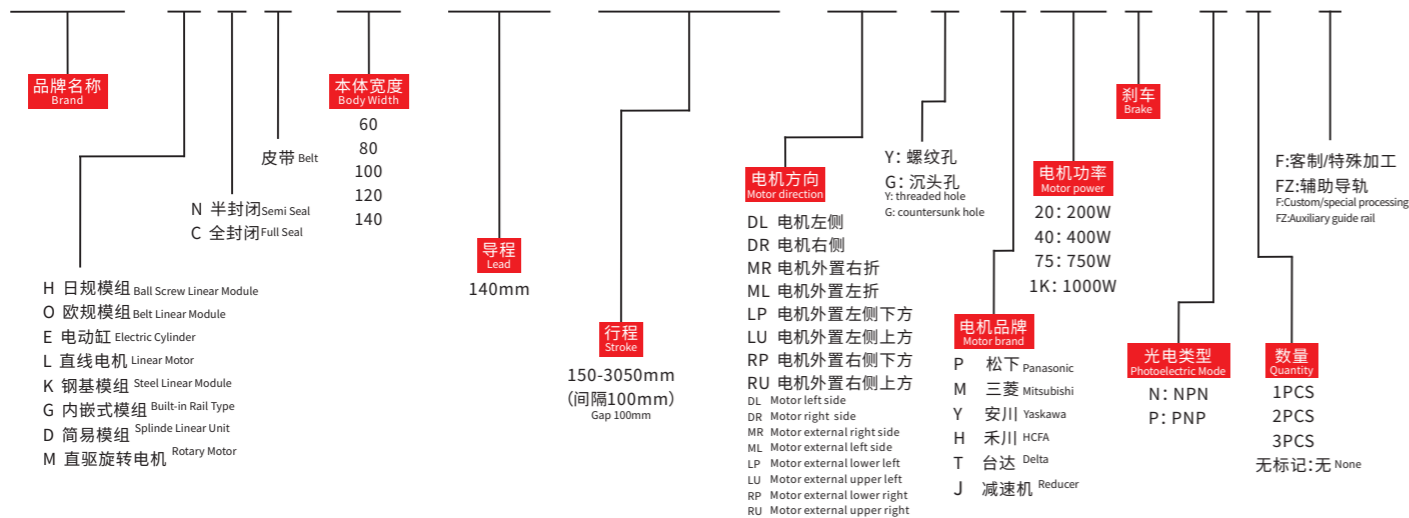

产品性能参数如下 Product performance parameters are as follows

规格 Spec	重复定位精度 (mm) Repeated positioning accuracy (mm)	±0.05					
	马达转速 (rpm/min) Rated Speed (rpm/min)	500	1000	1000	20	20	20
	最高速度 (mm/s) Maximum speed (mm/s)	1160	2300	3500	5600	5800	7000
	最大可搬重量 Maximum Payload	水平使用 (kg) Horizontal (kg)					
部品 Parts	导程 (mm) lead (mm)	140					
	定格推力 (N) Rated thrust (N)	71					
	标准行程 (mm) Stroke pitch (mm)	150~3050mm/100 间隔 100 mm Pitch					
	AC伺服马达容量 (W) AC servo motor output (w)	400					
	皮带宽度 (mm) Belt Width (mm)	30					
高刚性直线滑轨 (mm) High rigidity linear guide (mm)	20X17.5						
原点感应器 Home sensor	外挂 Outside	672 (NPN)					

※1 马达加减速设定0.4秒。
※1 Acceleration and deceleration value is set 0.4 second.

容许负载力矩表 N.m Allowable overhang

各行程M5后装螺帽数量 M5 nuts Qty.(by stroke)					
有效行程 Stroke	150~950	150~1450	150~1950	2050~2450	2500~3050
数量 Quantity	6	8	10	12	14

※滑台标准固定方式为下锁式, 使用M5后装螺帽固定。
※Standard mounting method is fix from the bottom, using the M5 bolt and nut.

容许负载力矩表 N.m Allowable overhang



(单位Unit:mm)					(单位Unit:mm)						
水平安装 Horizontal installation		线速度 Speed Maximum	A	B	C	侧面安装 Side installation		线速度 Speed Maximum	A	B	C
导程 140 Lead	4kg	7000mm/s	-	-	-	导程 140 Lead	4kg	7000mm/s	-	-	-
	6kg	5800mm/s	-	-	-		6kg	5800mm/s	-	-	-
	12kg	5600mm/s	-	-	-		12kg	5600mm/s	-	-	-
	18kg	3500mm/s	174	76	42		18kg	3500mm/s	42	76	174
	22kg	2300mm/s	225	71	42		22kg	2300mm/s	42	71	225
	28kg	1160mm/s	270	73	42		28kg	1160mm/s	42	73	270

搭配伺服马达一览表 Suitable motor brand

品牌 Brand	马达记号 Mark	刹车有无 Brake	马达容量 Motor capacity	电源电压 AC-Voltage	伺服马达型号 Servo motor model	驱动器型号 Driver Model
三菱 Mitsubishi	M	无刹车(水平式样) No brake (horizontal type)	750	220	HG-KR73	MR-J4-70A
松下 Panasonic	P	无刹车(水平式样) No brake (horizontal type)	750	220	MHMD082G1U	MBDHT3520
台达 Delta	T	无刹车(水平式样) No brake (horizontal type)	750	220	ECMA-C20807ES	ASD-B20721-B

速度-荷重曲线图 Acceleration-payload relationship

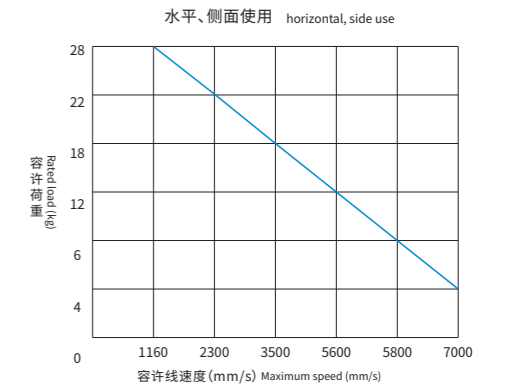

※以上使用条件请参考下方力矩表(最大值不可同时存在)。
※Please refer to the moment diagram below.(Do not reach all maximum value at same time.)

安装示意图 Installation diagram

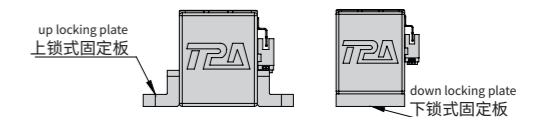

※上锁式固定板非标准品, 若有需求请另外追加选购。
※Top fixing plate is optional.

静态容许负载惯量 Static loading moment

(单位Unit:N.m)	
MY	71
MP	71
MR	20

※力矩表所表示的数据, 代表重心。
The torque value in the chart indicate the center of gravity.
※符合型录规范的正常试用下, 保证寿命为10000公里。
Operation life is 10,000km when the product is using under the specified conditions.
※吊钩使用无法套用标准规范, 如有需求请咨询我司业务。
The standard specification cannot be applied to the use of inverted crane.
Please consult our business if necessary.

电机左侧/电机右侧
Motor left side / Motor right side

DL 电机左侧 Motor left side

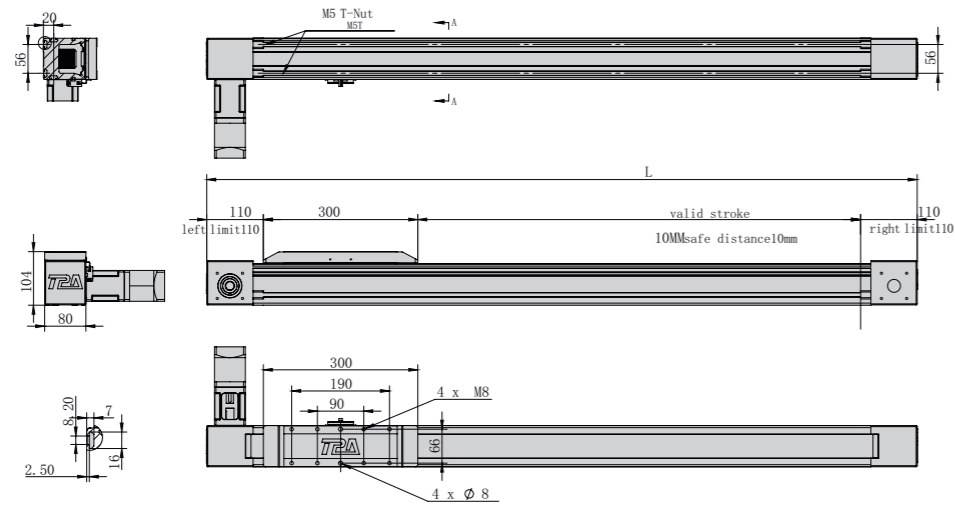

单位:Unit: mm

*不含电机和安装板重量 *Excluding motor and mounting plate weight

有效行程 Stroke	150	250	350	450	550	650	750	850	950	1050	1150	1250	1350	1450	1550
L	680	780	880	980	1080	1180	1280	1380	1480	1580	1680	1780	1880	1980	2080
KG	10.6	11.5	12.4	13.3	14.2	15.1	16	16.9	17.8	18.7	19.6	20.5	21.4	22.3	23.2

有效行程 Stroke	1650	1750	1850	1950	2050	2150	2250	2350	2450	2550	2650	2750	2850	2950	3050
L	2180	2280	2380	2480	2580	2680	2780	2880	2980	3080	3180	3280	3380	3480	3580
KG	24.1	25	25.9	26.8	27.7	28.6	29.5	30.4	31.3	32.2	33.1	34	34.9	35.8	36.7

OCB80-FZ 辅助导轨
OCB80-FZ Auxiliary guide rail

DL 电机左侧 Motor left side

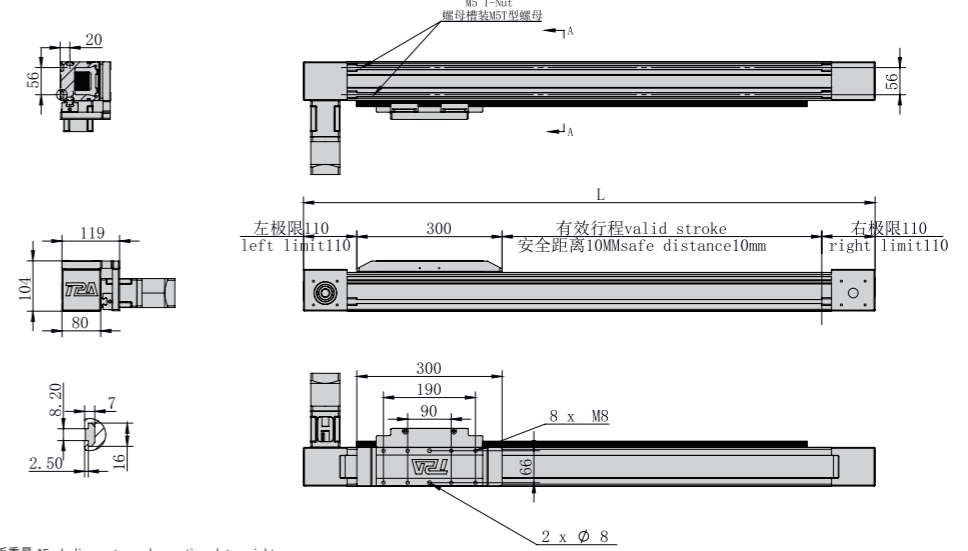

单位:Unit: mm

*不含电机和安装板重量 *Excluding motor and mounting plate weight

有效行程 Stroke	150	250	350	450	550	650	750	850	950	1050	1150	1250	1350	1450	1550
L	680	780	880	980	1080	1180	1280	1380	1480	1580	1680	1780	1880	1980	2080
KG	12.1	13.2	14.3	15.4	16.5	17.6	18.7	19.8	20.9	22	23.1	24.2	25.3	26.4	27.5

有效行程 Stroke	1650	1750	1850	1950	2050	2150	2250	2350	2450	2550	2650	2750	2850	2950	3050
L	2180	2280	2380	2480	2580	2680	2780	2880	2980	3080	3180	3280	3380	3480	3580
KG	28.6	29.7	30.8	31.9	33	34.1	35.2	36.3	37.4	38.5	39.6	40.7	41.8	42.9	44

DR 电机右侧 Motor right side

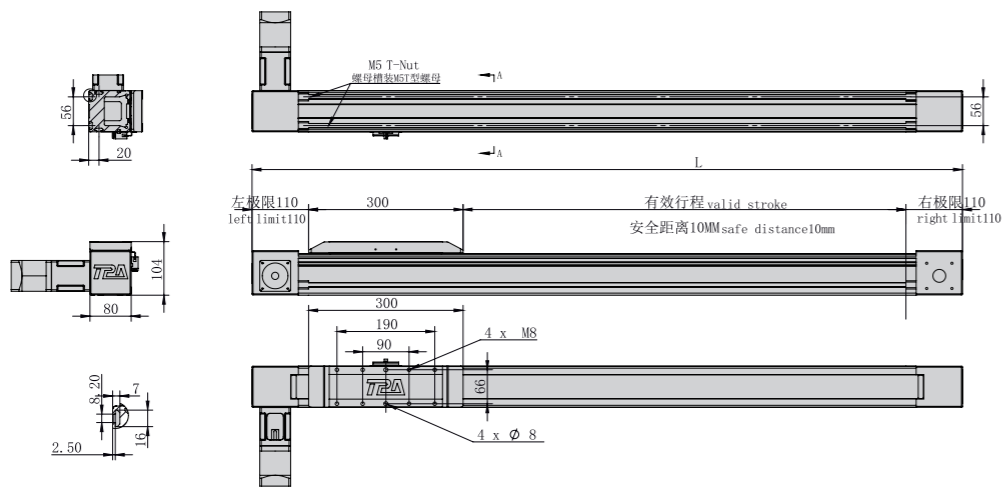

单位:Unit: mm

*不含电机和安装板重量 *Excluding motor and mounting plate weight

有效行程 Stroke	150	250	350	450	550	650	750	850	950	1050	1150	1250	1350	1450	1550
L	680	780	880	980	1080	1180	1280	1380	1480	1580	1680	1780	1880	1980	2080
KG	10.6	11.5	12.4	13.3	14.2	15.1	16	16.9	17.8	18.7	19.6	20.5	21.4	22.3	23.2

有效行程 Stroke	1650	1750	1850	1950	2050	2150	2250	2350	2450	2550	2650	2750	2850	2950	3050
L	2180	2280	2380	2480	2580	2680	2780	2880	2980	3080	3180	3280	3380	3480	3580
KG	24.1	25	25.9	26.8	27.7	28.6	29.5	30.4	31.3	32.2	33.1	34	34.9	35.8	36.7

DR 电机右侧 Motor right side

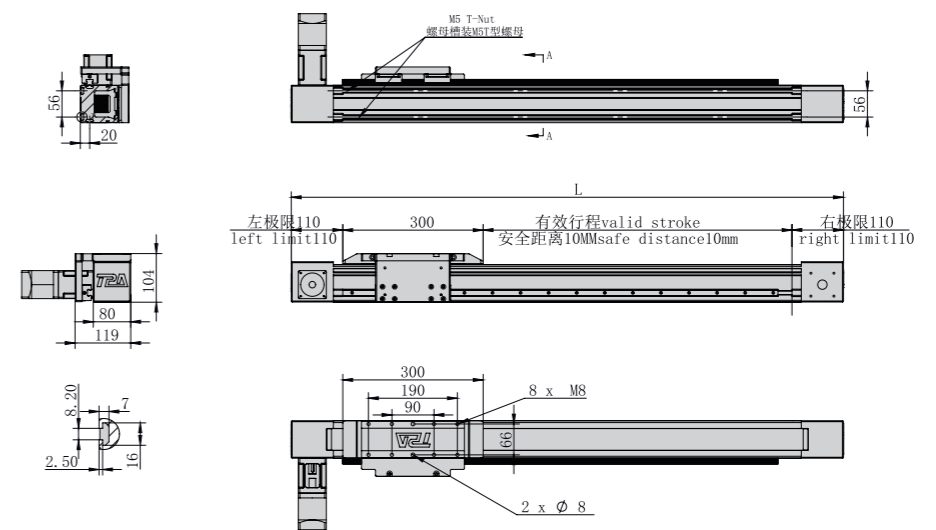

单位:Unit: mm

*不含电机和安装板重量 *Excluding motor and mounting plate weight

有效行程 Stroke	150	250	350	450	550	650	750	850	950	1050	1150	1250	1350	1450	1550
L	680	780	880	980	1080	1180	1280	1380	1480	1580	1680	1780	1880	1980	2080
KG	12.1	13.2	14.3	15.4	16.5	17.6	18.7	19.8	20.9	22	23.1	24.2	25.3	26.4	27.5

有效行程 Stroke	1650	1750	1850	1950	2050	2150	2250	2350	2450	2550	2650	2750	2850	2950	3050
L	2180	2280	2380	2480	2580	2680	2780	2880	2980	3080	3180	3280	3380	3480	3580
KG	28.6	29.7	30.8	31.9	33	34.1	35.2	36.3	37.4	38.5	39.6	40.7	41.8	42.9	44

重复精度
Repeat Accuracy
±0.05
mm



此图仅供参考, 出货规格详见尺寸图面
This picture for reference only, specs details according with the drawing.

最大行程
Max Stroke 3050mm

最高速度
Max Speed 5000mm/s

马达容量
Motor Output 400W

皮带宽度
Belt Width 30mm

直线导轨
Linear Guide 20X17.5-1支

型号表达方式 Ordering method

TPA-OCB-80S-140-L3050-DL-Y-P40B-N3-F

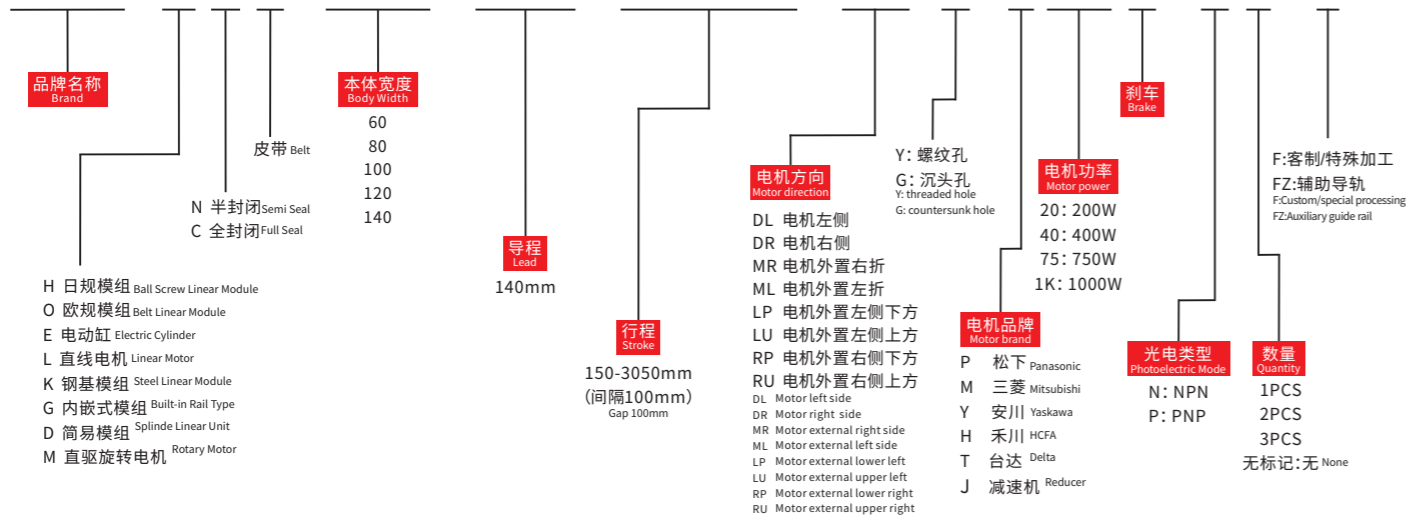

产品性能参数如下 Product performance parameters are as follows

规格 Spec	重复定位精度 (mm) Repeated positioning accuracy (mm)	±0.05					
	马达转速 (rpm/min) Rated Speed (rpm/min)	500	1000	1000	20	20	20
	最高速度 (mm/s) Maximum speed (mm/s)	1160	2300	3500	5600	5800	7000
	最大可搬重量 Maximum Payload	水平使用 (kg) Horizontal (kg)					
部品 Parts	导程 (mm) lead (mm)	140					
	定格推力 (N) Rated thrust (N)	71					
	标准行程 (mm) Stroke pitch (mm)	150~3050mm/100 间隔 100 mm Pitch					
	AC伺服马达容量 (W) AC servo motor output (w)	400					
	皮带宽度 (mm) Belt Width (mm)	30					
	高刚性直线导轨 (mm) High rigidity linear guide (mm)	20X17.5					
原点感应器 Home sensor	外挂 Outside	672 (NPN)					

※1 马达加减速设定0.4秒。
※1 Acceleration and deceleration value is set 0.4 second.

容许负载力矩表 N.m Allowable overhang

各行程M5后装螺帽数量 M5 nuts Qty.(by stroke)		150~950	150~1450	150~1950	2050~2450	2500~3050
有效行程 Stroke	数量 Quantity	6	8	10	12	14

※滑台标准固定方式为下锁式, 使用M5后装螺帽固定。
※Standard mounting method is fix from the bottom, using the M5 bolt and nut.

容许负载力矩表 N.m Allowable overhang



		水平安装 Horizontal installation			侧面安装 Side installation				
		线速度 Speed Maximum	A	B	线速度 Speed Maximum	A	B	C	
导程 140 Lead	4kg	7000mm/s	-	-	4kg	7000mm/s	-	-	
	6kg	5800mm/s	-	-	6kg	5800mm/s	-	-	
	9kg	5600mm/s	-	-	9kg	5600mm/s	-	-	
	13kg	3500mm/s	174	76	13kg	3500mm/s	42	76	174
	18kg	2300mm/s	225	71	18kg	2300mm/s	42	71	225
	22kg	1160mm/s	270	73	22kg	1160mm/s	42	73	270

搭配伺服马达一览表 Suitable motor brand

品牌 Brand	马达记号 Mark	刹车有无 Brake	马达容量 Motor capacity	电源电压 AC-Voltage	伺服马达型号 Servo motor model	驱动器型号 Driver Model
三菱 Mitsubishi	M	无刹车(水平式样) No brake (horizontal type)	750	220	HG-KR73	MR-J4-70A
松下 Panasonic	P	无刹车(水平式样) No brake (horizontal type)	750	220	MHMD082G1U	MBDHT3520
台达 Delta	T	无刹车(水平式样) No brake (horizontal type)	750	220	ECMA-C20807ES	ASD-B20721-B

速度-荷重曲线图 Acceleration-payload relationship

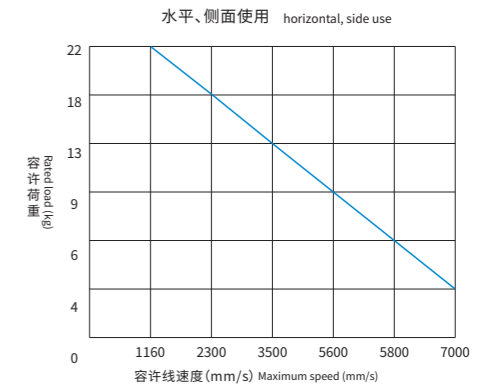

*以上使用条件请参考下方力矩表(最大值不可同时存在)。
*Please refer to the moment diagram below.(Do not reach all maximum value at same time.)

安装示意图 Installation diagram

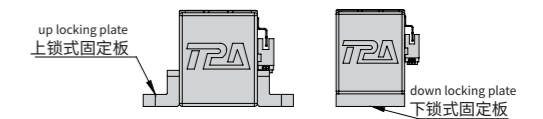

※上锁式固定板非标准品, 若有需求请另外追加选购。
※Top fixing plate is optional.

静态容许负载质量 Static loading moment

		静态容许负载质量 Static loading moment	
		MY	MP
MY	71		
MP	71		
MR	20		

*力矩表所表示的数据, 代表重心。
The torque value in the chart indicate the center of gravity.
*符合型录规范的正常试用下, 保证寿命为10000公里。
Operation life is 10,000km when the product is using under the specified conditions.
*侧吊使用无法套用标准规范, 如有需求请咨询我司业务。
The standard specification cannot be applied to the use of inverted crane.
Please consult our business if necessary.

电机左侧/电机右侧
Motor left side / Motor right side

DL 电机左侧 Motor left side

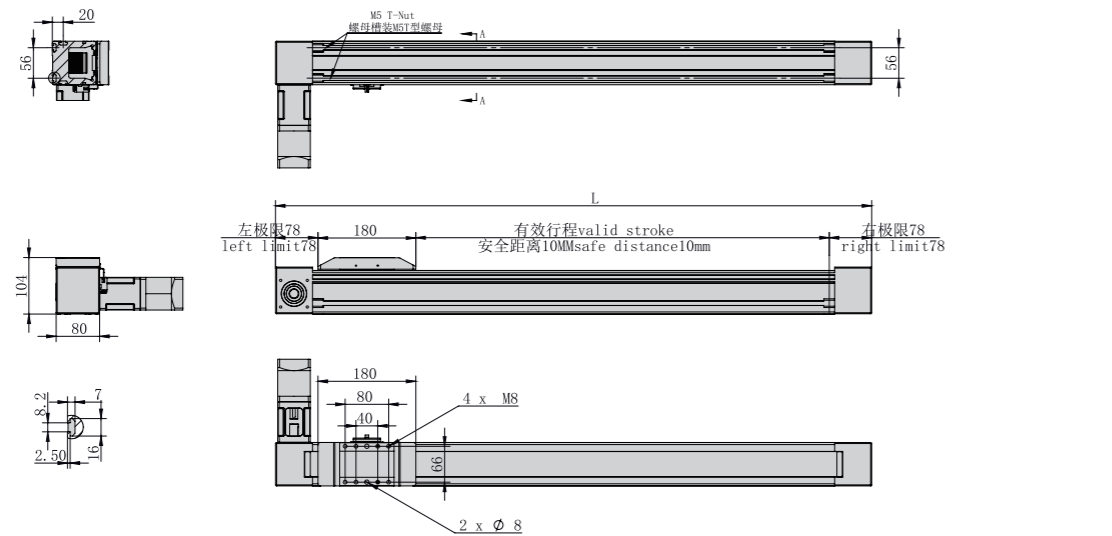

单位:Unit: mm

*不含电机和安装板重量 *Excluding motor and mounting plate weight

有效行程 Stroke	150	250	350	450	550	650	750	850	950	1050	1150	1250	1350	1450	1550
L	496	596	696	796	896	996	1096	1196	1296	1396	1496	1596	1696	1796	1896
KG	9.8	10.7	11.6	12.5	13.4	14.3	15.2	16.1	17	17.9	18.8	19.7	20.6	21.5	22.4

有效行程 Stroke	1650	1750	1850	1950	2050	2150	2250	2350	2450	2550	2650	2750	2850	2950	3050
L	1996	2096	2196	2296	2396	2496	2596	2696	2796	2896	2996	3096	3196	3296	3396
KG	23.3	24.2	25.1	26	26.9	27.8	28.7	29.6	30.5	31.4	32.3	33.2	34.1	35	35.9

OCB80S-FZ 辅助导轨
OCB80S-FZ Auxiliary guide rail

DL 电机左侧 Motor left side

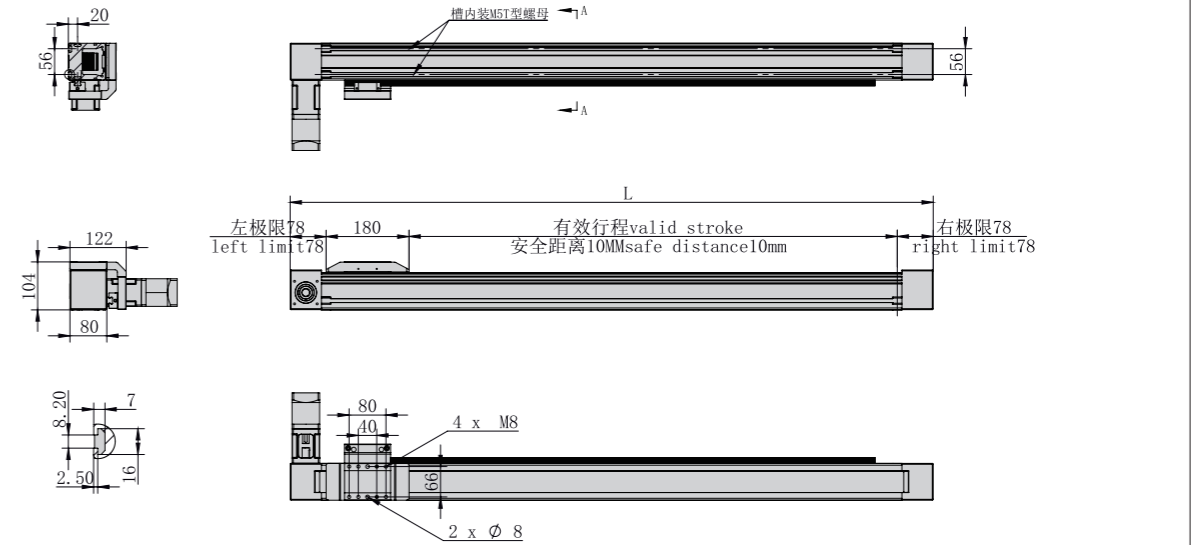

单位:Unit: mm

*不含电机和安装板重量 *Excluding motor and mounting plate weight

有效行程 Stroke	150	250	350	450	550	650	750	850	950	1050	1150	1250	1350	1450	1550
L	596	696	796	896	996	1096	1196	1296	1396	1496	1596	1696	1796	1896	1996
KG	10.8	11.9	13	14.1	15.2	16.3	17.4	18.5	19.6	20.7	21.8	22.9	24	25.1	26.2

有效行程 Stroke	1650	1750	1850	1950	2050	2150	2250	2350	2450	2550	2650	2750	2850	2950	3050
L	2096	2196	2296	2396	2496	2596	2696	2796	2896	2996	3096	3196	3296	3396	3496
KG	27.3	28.4	29.5	30.6	31.7	32.8	33.9	35	36.1	37.2	38.3	39.4	40.5	41.6	42.7

DR 电机右侧 Motor right side

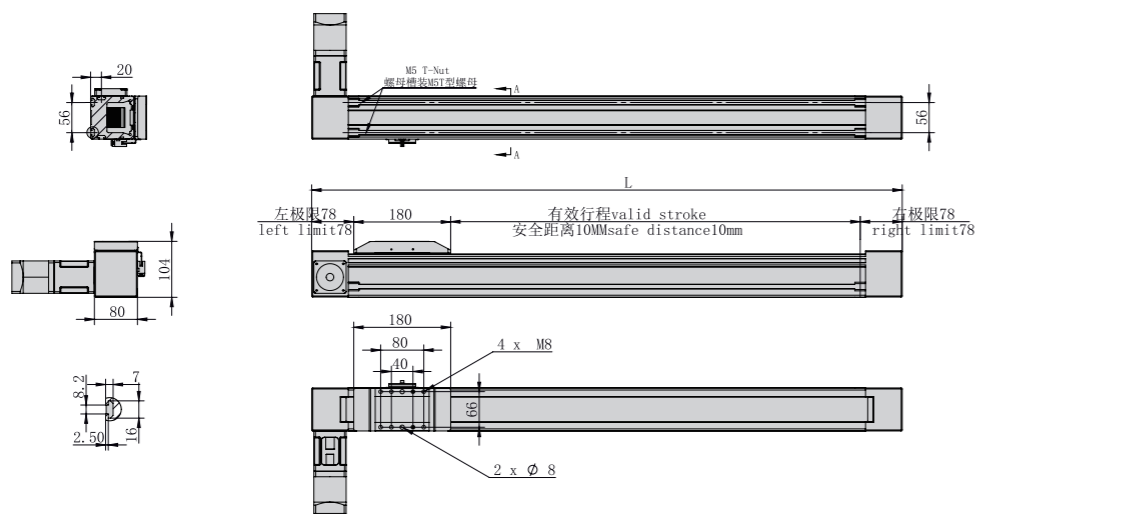

单位:Unit: mm

*不含电机和安装板重量 *Excluding motor and mounting plate weight

有效行程 Stroke	150	250	350	450	550	650	750	850	950	1050	1150	1250	1350	1450	1550
L	496	596	696	796	896	996	1096	1196	1296	1396	1496	1596	1696	1796	1896
KG	9.8	10.7	11.6	12.5	13.4	14.3	15.2	16.1	17	17.9	18.8	19.7	20.6	21.5	22.4

有效行程 Stroke	1650	1750	1850	1950	2050	2150	2250	2350	2450	2550	2650	2750	2850	2950	3050
L	1996	2096	2196	2296	2396	2496	2596	2696	2796	2896	2996	3096	3196	3296	3396
KG	23.3	24.2	25.1	26	26.9	27.8	28.7	29.6	30.5	31.4	32.3	33.2	34.1	35	35.9

DR 电机右侧 Motor right side

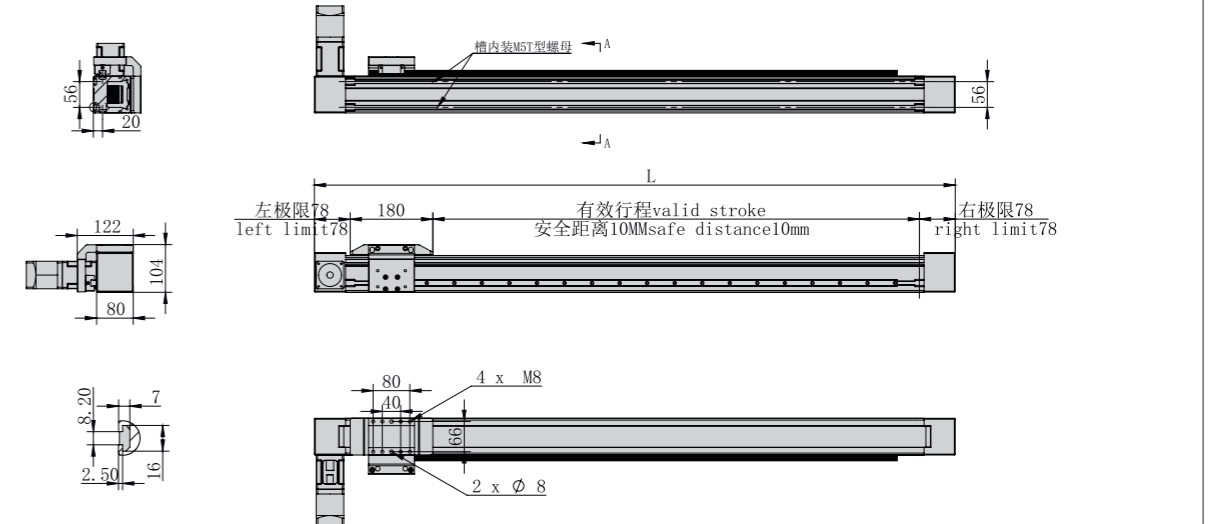

单位:Unit: mm

*不含电机和安装板重量 *Excluding motor and mounting plate weight

有效行程 Stroke	150	250	350	450	550	650	750	850	950	1050	1150	1250	1350	1450	1550
L	596	696	796	896	996	1096	1196	1296	1396	1496	1596	1696	1796	1896	1996
KG	10.8	11.9	13	14.1	15.2	16.3	17.4	18.5	19.6	20.7	21.8	22.9	24	25.1	26.2

有效行程 Stroke	1650	1750	1850	1950	2050	2150	2250	2350	2450	2550	2650	2750	2850	2950	3050
L	2096	2196	2296	2396	2496	2596	2696	2796	2896	2996	3096	3196	3296	3396	3496
KG	27.3	28.4	29.5	30.6	31.7	32.8	33.9	35	36.1	37.2	38.3	39.4	40.5	41.6	42.7

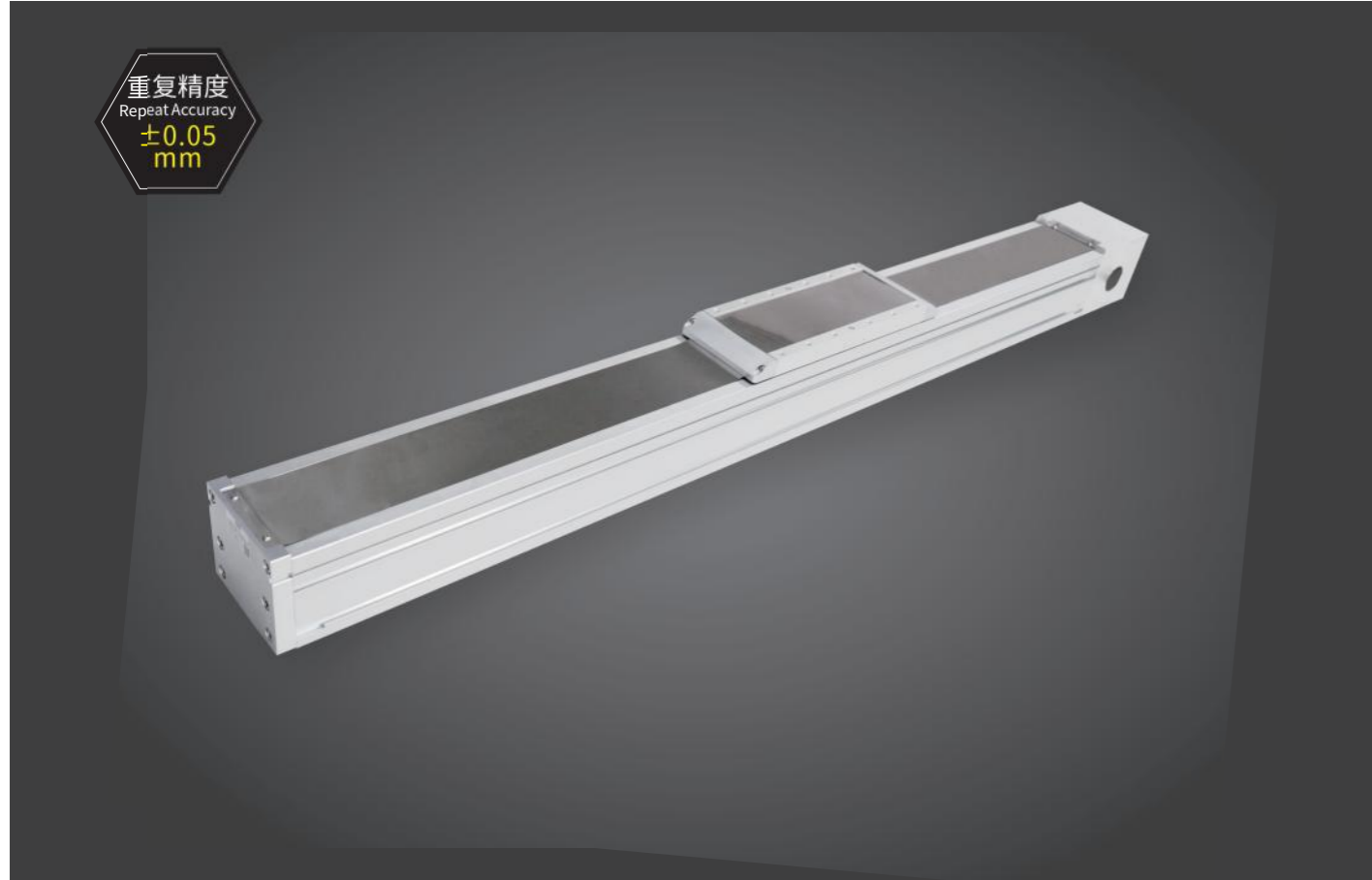

此图仅供参考, 出货规格详见尺寸图面
This picture for reference only, specs details according with the drawing.

最大行程 Max Stroke	3050mm	最高速度 Max Speed	9600mm/s	马达容量 Motor Output	750W	皮带宽度 Belt Width	50mm	直线滑轨 Linear Guide	30X23-1支
--------------------	--------	-------------------	----------	----------------------	------	--------------------	------	----------------------	----------

型号表达方式 Ordering method

TPA-OCB-100-192-L3050-DL-Y-P75B-N3-F

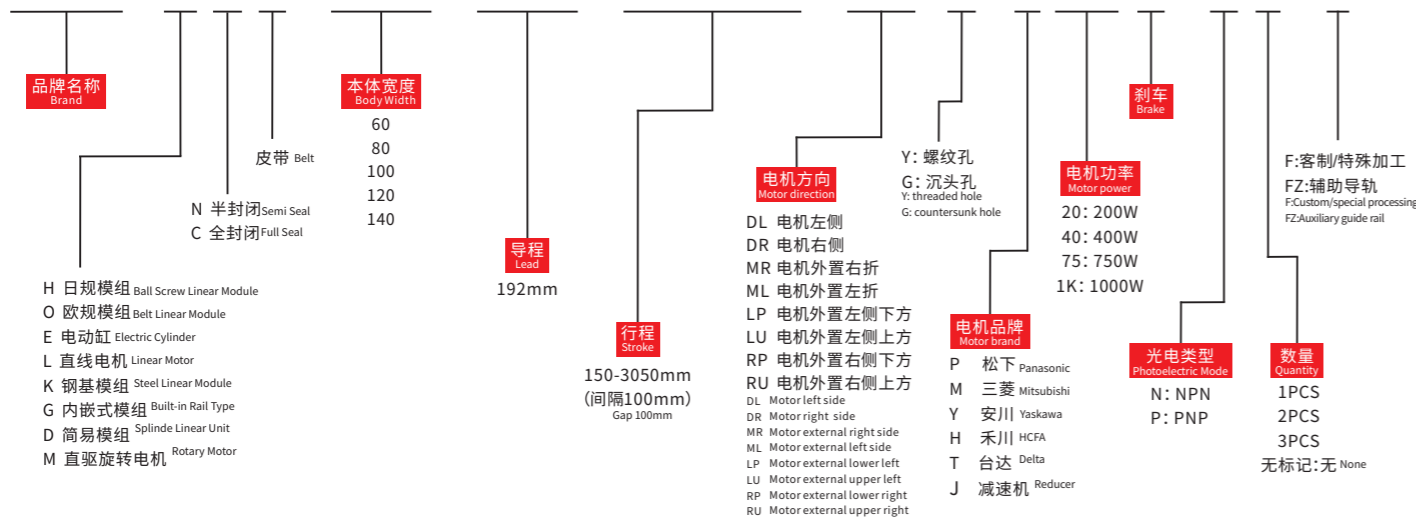

产品性能参数如下 Product performance parameters are as follows

规格 Spec	重复定位精度 (mm) Repeated positioning accuracy (mm)	±0.05					
	马达转速 (rpm/min) Rated Speed (rpm/min)	500	1000	1050	2000	2500	3000
	最高速度 (mm/s) Maximum speed (mm/s)	1600	3200	4800	6400	8000	9600
	最大可搬重量 Maximum Payload	水平使用 (kg) Horizontal (kg)					
部品 Parts	导程 (mm) lead (mm)	192					
	定格推力 (N) Rated thrust (N)	63					
	标准行程 (mm) Stroke pitch (mm)	150~3050mm/100 间隔 100 mm Pitch					
	AC伺服马达容量 (W) AC servo motor output (w)	750					
	皮带宽度 (mm) Belt Width (mm)	50					
	高刚性直线滑轨 (mm) High rigidity linear guide (mm)	30X23					
原点感应器 Home sensor	外挂 Outside	672 (NPN)					

※1 马达加速度设定0.4秒。
※1 Acceleration and deceleration value is set 0.4 second.

容许负载力矩表 N.m Allowable overhang

各行程M5后装螺帽数量 M5 nuts Qty.(by stroke)		150~950	150~1450	150~1950	2050~2450	2550~3050
有效行程 Stroke	数量 Quantity	6	8	10	12	14

※滑台标准固定方式为下锁式, 使用M5后装螺帽固定。
※Standard mounting method is fix from the bottom, using the M5 bolt and nut.

容许负载力矩表 N.m Allowable overhang



水平安装 Horizontal installation		线速度 Speed Maximum	A	B	C	侧面安装 Horizontal installation		线速度 Speed Maximum	A	B	C
导程 192 Lead	2kg	9600mm/s	-	-	-	导程 192 Lead	2kg	9600mm/s	-	-	-
	5kg	8000mm/s	-	-	-		5kg	8000mm/s	-	-	-
	12kg	6400mm/s	-	-	-		12kg	6400mm/s	-	-	-
	20kg	4800mm/s	-	-	-		20kg	4800mm/s	-	-	-
	26kg	3200mm/s	200	45	50		26kg	3200mm/s	50	45	200
	33kg	1600mm/s	120	30	40		33kg	1600mm/s	40	30	120

搭配伺服马达一览表 Suitable motor brand

品牌 Brand	马达记号 Mark	刹车有无 Brake	马达容量 Motor capacity	电源电压 AC-Voltage	伺服马达型号 Servo motor model	驱动器型号 Driver Model
三菱 Mitsubishi	M	无刹车(水平式样) No brake (horizontal type)	750	220	HG-KR73	MR-J4-70A
松下 Panasonic	P	无刹车(水平式样) No brake (horizontal type)	750	220	MHMD082G1U	MBDHT3520
台达 Delta	T	无刹车(水平式样) No brake (horizontal type)	750	220	ECMA-C20807ES	ASD-B20721-B

速度-荷重曲线图 Acceleration-payload relationship

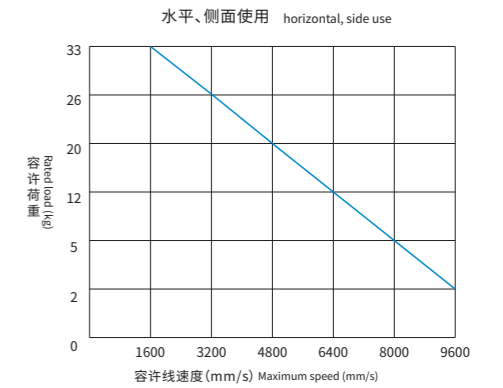

*以上使用条件请参考下方力矩表(最大值不可同时存在)。
*Please refer to the moment diagram below.(Do not reach all maximum value at same time.)

安装示意图 Installation diagram

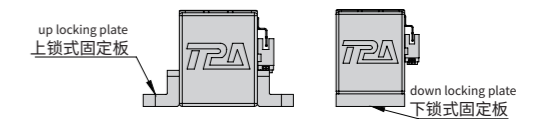

※上锁式固定板非标准品, 若有需求请另追加选购。
※Top fixing plate is optional.

静态容许负载惯量 Static loading moment

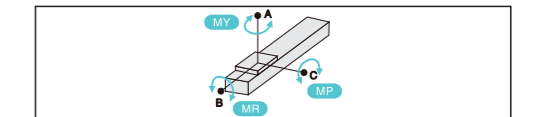

品牌	静态容许负载惯量 (单位Unit:N.m)
MY	63
MP	63
MR	25

*力矩表所表示的数据, 代表重心。
The torque value in the chart indicate the center of gravity.
*符合型录规范的正常试用下, 保证寿命为10000公里。
Operation life is 10,000km when the product is using under the specified conditions.
*倒吊使用无法套用标准规范, 如有需求请咨询我司业务。
The standard specification cannot be applied to the use of inverted crane.
Please consult our business if necessary.



电机左侧/电机右侧
Motor left side / Motor right side

DL 电机左侧 Motor left side

单位:Unit: mm

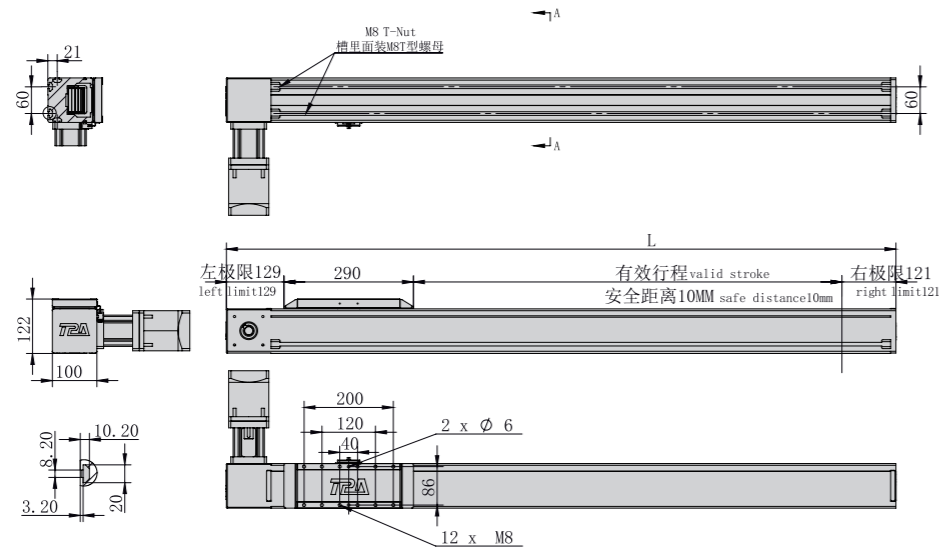

*不含电机和安装板重量 *Excluding motor and mounting plate weight

有效行程 Stroke	150	250	350	450	550	650	750	850	950	1050	1150	1250	1350	1450	1550
L	700	800	900	1000	1100	1200	1300	1400	1500	1600	1700	1800	1900	2000	2100
KG	15.6	17.1	18.6	20.1	21.6	23.1	24.6	26.1	27.6	29.1	30.6	32.1	33.6	35.1	36.6

有效行程 Stroke	1650	1750	1850	1950	2050	2150	2250	2350	2450	2550	2650	2750	2850	2950	3050
L	2200	2300	2400	2500	2600	2700	2800	2900	3000	3100	3200	3300	3400	3500	3600
KG	38.1	39.6	41.1	42.6	44.1	45.6	47.1	48.6	50.1	51.6	53.1	54.6	56.1	57.6	59.1

OCB100-FZ 辅助导轨
OCB100-FZ Auxiliary guide rail

DL 电机左侧 Motor left side

单位:Unit: mm

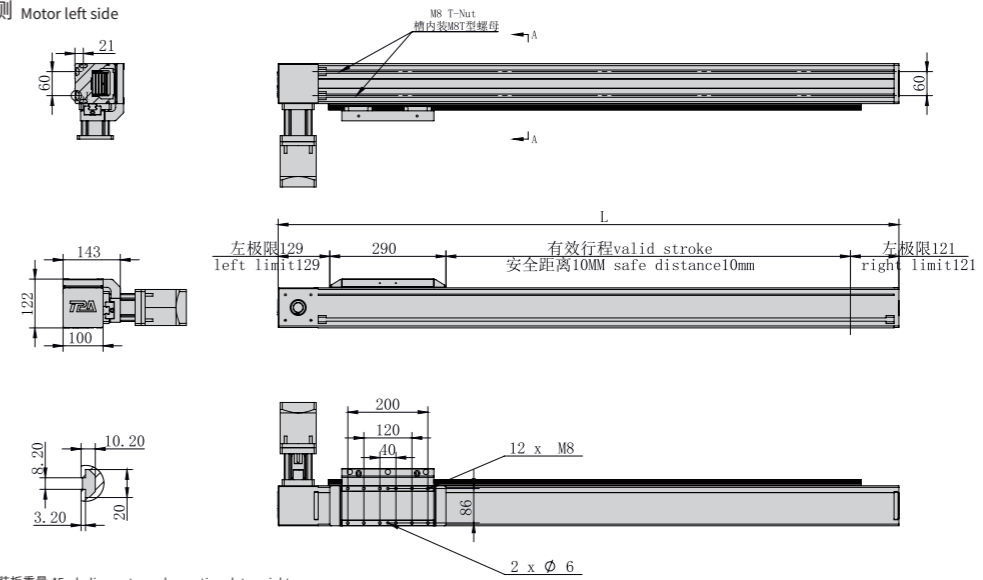

*不含电机和安装板重量 *Excluding motor and mounting plate weight

有效行程 Stroke	150	250	350	450	550	650	750	850	950	1050	1150	1250	1350	1450	1550
L	700	800	900	1000	1100	1200	1300	1400	1500	1600	1700	1800	1900	2000	2100
KG	18.1	19.7	21.3	22.9	24.5	26.1	27.7	29.3	30.9	32.5	34.1	35.7	37.3	38.9	40.5

有效行程 Stroke	1650	1750	1850	1950	2050	2150	2250	2350	2450	2550	2650	2750	2850	2950	3050
L	2200	2300	2400	2500	2600	2700	2800	2900	3000	3100	3200	3300	3400	3500	3600
KG	42.1	43.7	45.3	46.9	48.5	50.1	51.7	53.3	54.9	56.5	58.1	59.7	61.3	62.9	64.5

DR 电机右侧 Motor right side

单位:Unit: mm

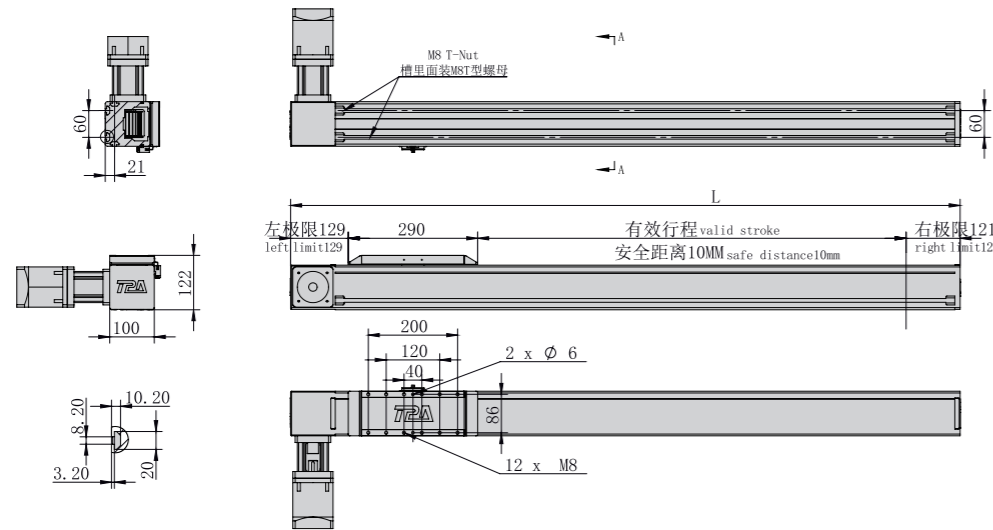

*不含电机和安装板重量 *Excluding motor and mounting plate weight

有效行程 Stroke	150	250	350	450	550	650	750	850	950	1050	1150	1250	1350	1450	1550
L	700	800	900	1000	1100	1200	1300	1400	1500	1600	1700	1800	1900	2000	2100
KG	15.6	17.1	18.6	20.1	21.6	23.1	24.6	26.1	27.6	29.1	30.6	32.1	33.6	35.1	36.6

有效行程 Stroke	1650	1750	1850	1950	2050	2150	2250	2350	2450	2550	2650	2750	2850	2950	3050
L	2200	2300	2400	2500	2600	2700	2800	2900	3000	3100	3200	3300	3400	3500	3600
KG	38.1	39.6	41.1	42.6	44.1	45.6	47.1	48.6	50.1	51.6	53.1	54.6	56.1	57.6	59.1

DR 电机右侧 Motor right side

单位:Unit: mm

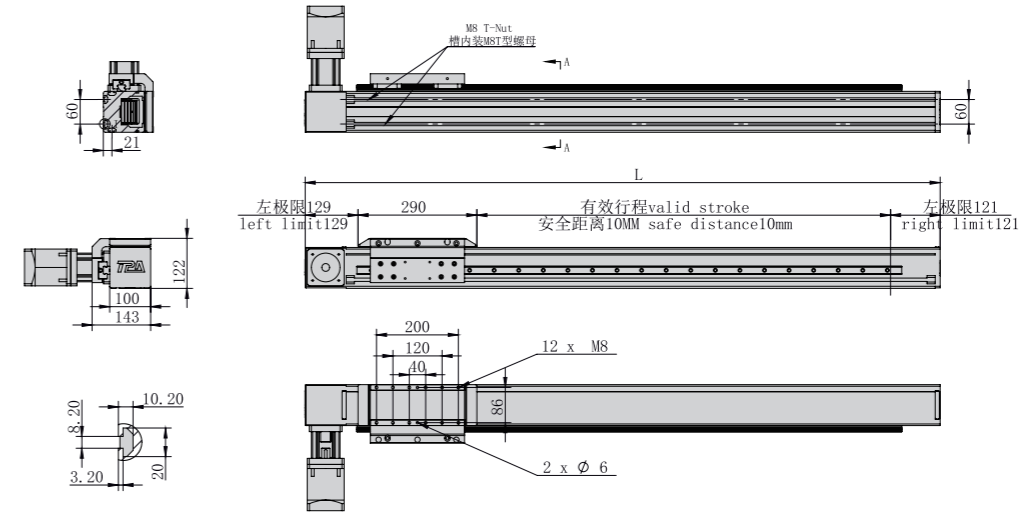

*不含电机和安装板重量 *Excluding motor and mounting plate weight

有效行程 Stroke	150	250	350	450	550	650	750	850	950	1050	1150	1250	1350	1450	1550
L	700	800	900	1000	1100	1200	1300	1400	1500	1600	1700	1800	1900	2000	2100
KG	18.1	19.7	21.3	22.9	24.5	26.1	27.7	29.3	30.9	32.5	34.1	35.7	37.3	38.9	40.5

有效行程 Stroke	1650	1750	1850	1950	2050	2150	2250	2350	2450	2550	2650	2750	2850	2950	3050
L	2200	2300	2400	2500	2600	2700	2800	2900	3000	3100	3200	3300	3400	3500	3600
KG	42.1	43.7	45.3	46.9	48.5	50.1	51.7	53.3	54.9	56.5	58.1	59.7	61.3	62.9	64.5

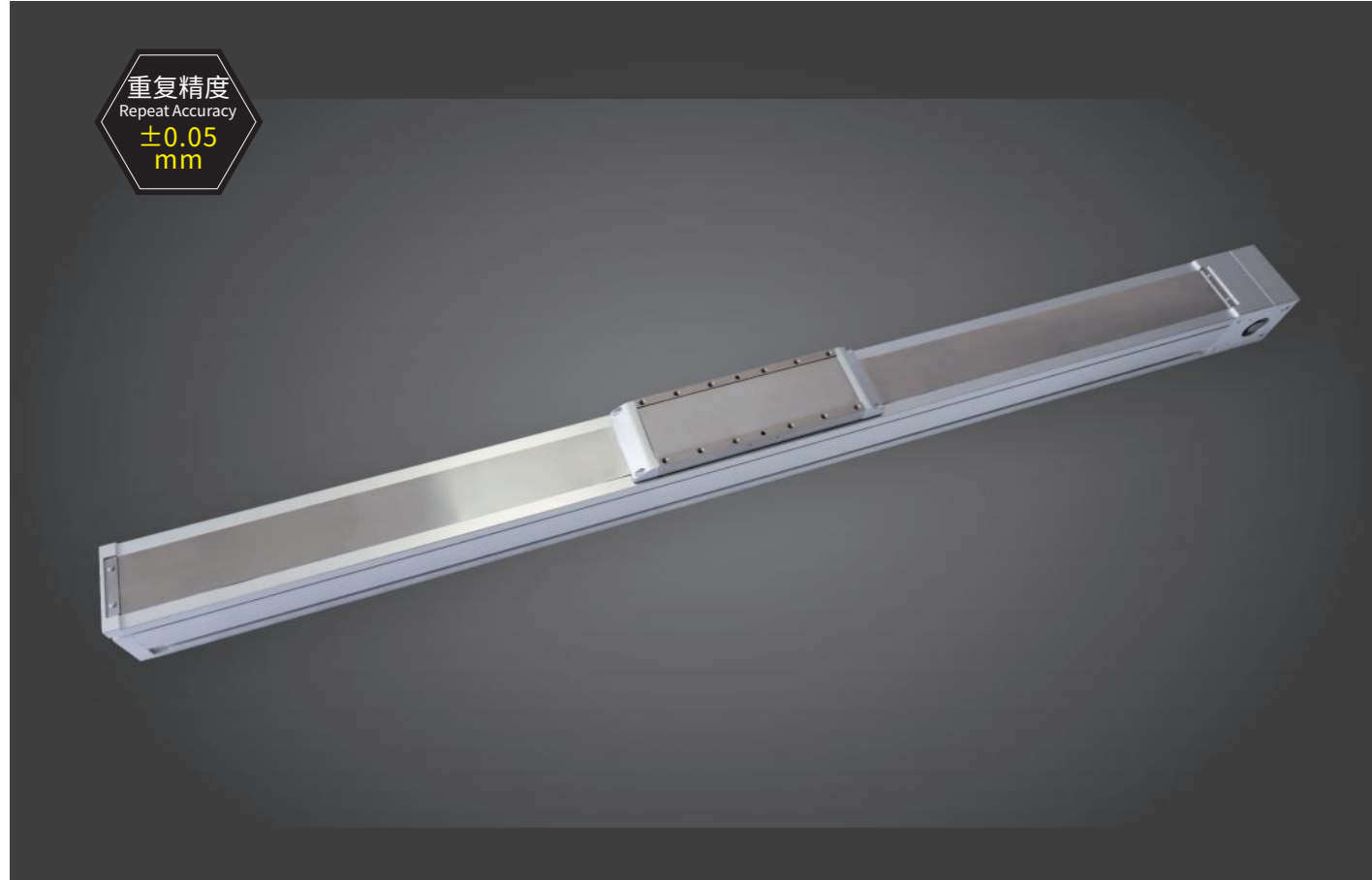

重复精度
Repeat Accuracy
±0.05 mm

此图仅供参考, 出货规格详见尺寸图面
This picture for reference only, specs details according with the drawing.

- 最大行程 Max Stroke: 4050mm
- 最高速度 Max Speed: 5000mm/s
- 马达容量 Motor Output: 750W
- 皮带宽度 Belt Width: 50mm
- 直线滑轨 Linear Guide: 30X26-1支

型号表达方式 Ordering method

TPA-OCB-120-224-L4050-DL-Y-P75B-N3-F

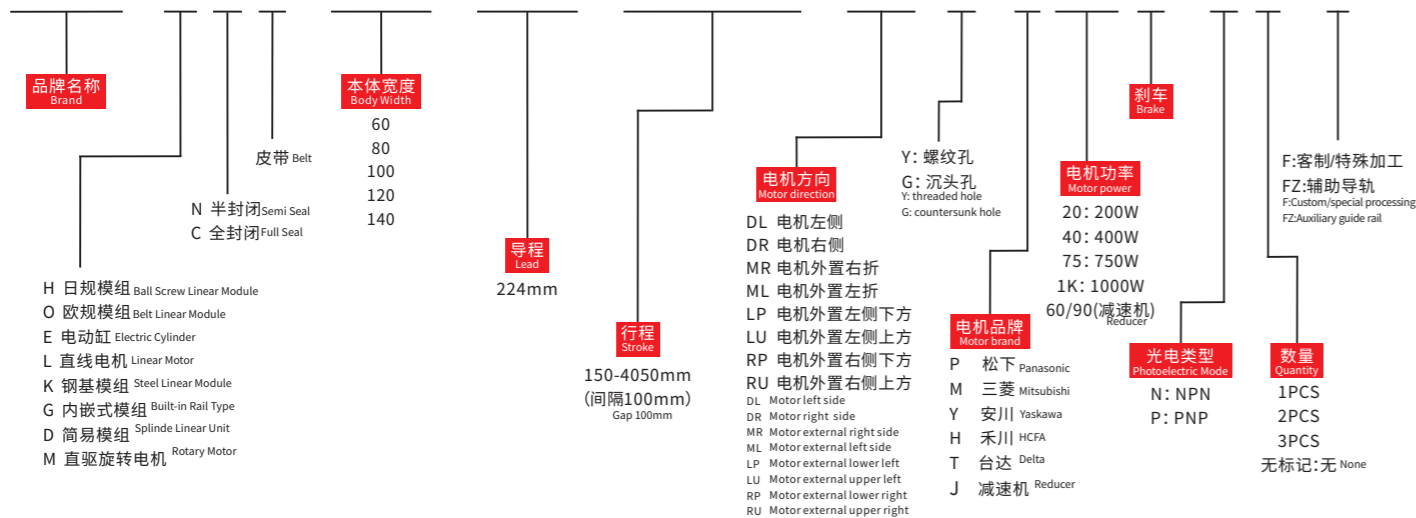

产品性能参数如下 Product performance parameters are as follows

规格 Spec	重复定位精度 (mm) Repeated positioning accuracy (mm)	±0.05					
	马达转速 (rpm/min) Rated Speed (rpm/min)	500	1000	1500	2000	2500	3000
	最高速度 (mm/s) Maximum speed (mm/s)	1870	3700	5600	7470	9300	11200
	最大可搬重量 Maximum Payload	水平使用 (kg) Horizontal (kg)					
部品 Parts	导程 (mm) lead (mm)	224					
	定格推力 (N) Rated thrust (N)	55					
	标准行程 (mm) Stroke pitch (mm)	150~4050mm/100 间隔 100 mm Pitch					
	AC伺服马达容量 (W) AC servo motor output (w)	750					
	皮带宽度 (mm) Belt Width (mm)	50					
	高刚性直线滑轨 (mm) High rigidity linear guide (mm)	30X26					
原点球型感应器 Home sensor	外挂 Outside	672 (NPN)					

※1 马达加减速设定0.4秒。
※1 Acceleration and deceleration value is set 0.4 second.

容许负载力矩表 N.m Allowable overhang

有效行程 Stroke	150-950	150-1450	150-1950	2050-2450	2550-4050
数量 Quantity	6	8	10	12	20

※滑台标准固定方式为下锁式, 使用M5后装螺帽固定。
※Standard mounting method is fix from the bottom, using the M5 bolt and nut.

容许负载力矩表 N.m Allowable overhang



导程 224 Lead	水平安装 Horizontal installation			侧面安装 Side installation		
	线速度 Speed Maximum	A	B	线速度 Speed Maximum	A	B
2kg	11200mm/s	-	-	2kg	11200mm/s	-
4kg	9300mm/s	-	-	4kg	9300mm/s	-
8kg	7470mm/s	-	-	8kg	7470mm/s	-
12kg	5600mm/s	-	-	12kg	5600mm/s	-
22kg	3700mm/s	240	80	22kg	3700mm/s	20
38kg	1870mm/s	200	60	38kg	1870mm/s	10

搭配伺服马达一览表 Suitable motor brand

品牌 Brand	马达记号 Mark	刹车有无 Brake	马达容量 Motor capacity	电源电压 AC-Voltage	伺服马达型号 Servo motor model	驱动器型号 Driver Model
三菱 Mitsubishi	M	无刹车(水平式样) No brake (horizontal type)	750	220	HG-KR73	MR-J4-70A
松下 Panasonic	P	无刹车(水平式样) No brake (horizontal type)	750	220	MHMD082G1U	MBDHT3520
台达 Delta	T	无刹车(水平式样) No brake (horizontal type)	750	220	ECMA-C20807ES	ASD-B20721-B

速度-荷重曲线图 Acceleration-payload relationship

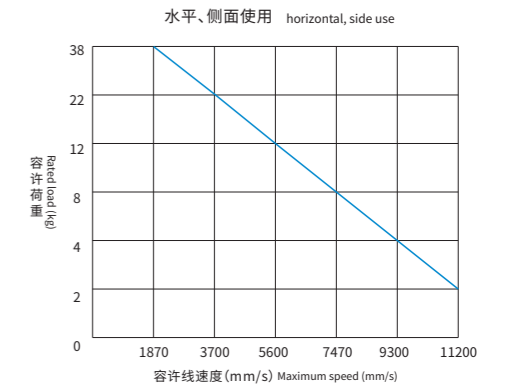

*以上使用条件请参考下方力矩表(最大值不可同时存在)。
*Please refer to the moment diagram below.(Do not reach all maximum value at same time.)

安装示意图 Installation diagram

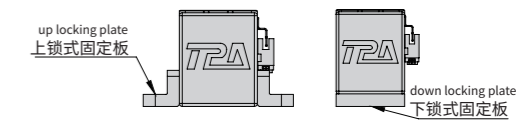

※上锁式固定板非标准品, 若有需求请另追加选购。
※Top fixing plate is optional.

静态容许负载惯量 Static loading moment

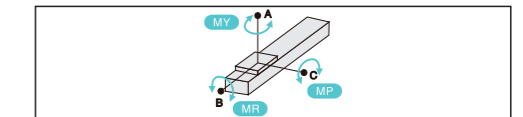

点 Point	惯量 Inertia (N.m)
MY	55
MP	55
MR	30

*力矩表所表示的数据, 代表重心。
The torque value in the chart indicate the center of gravity.
*符合型录规范的正常试用下, 保证寿命为10000公里。
Operation life is 10,000km when the product is using under the specified conditions.
*倒吊使用无法套用标准规范, 如有需求请咨询我司业务。
The standard specification cannot be applied to the use of inverted crane.
Please consult our business if necessary.



电机左侧/电机右侧
Motor left side / Motor right side

DL 电机左侧 Motor left side

单位:Unit: mm

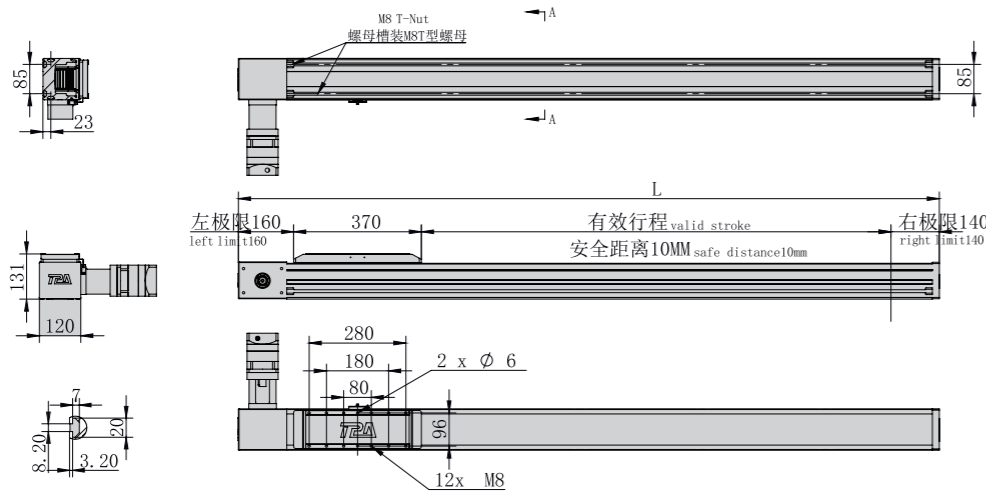

*不含电机和安装板重量 *Excluding motor and mounting plate weight

有效行程 Stroke	150	250	350	450	550	650	750	850	950	1050	1150	1250	1350	1450	1550	1650	1750	1850	1950	2050
L	830	930	1030	1130	1230	1330	1430	1530	1630	1730	1830	1930	2030	2130	2230	2330	2430	2530	2630	2730
KG	20.9	22.5	24.1	25.7	27.3	28.9	30.5	32.1	33.7	35.3	36.9	38.5	40.1	41.7	43.3	44.9	46.5	48.1	49.7	51.3

有效行程 Stroke	2150	2250	2350	2450	2550	2650	2750	2850	2950	3050	3150	3250	3350	3450	3550	3650	3750	3850	3950	4050
L	2830	2930	3030	3130	3230	3330	3430	3530	3630	3730	3830	3930	4030	4130	4230	4330	4430	4530	4630	4730
KG	52.9	54.5	56.1	57.7	59.3	60.9	62.5	64.1	65.7	67.3	68.9	70.5	72.1	73.7	75.3	76.9	78.5	80.1	81.7	83.3

OCB120-FZ 辅助导轨
OCB120-FZ Auxiliary guide rail

DL 电机左侧 Motor left side

单位:Unit: mm

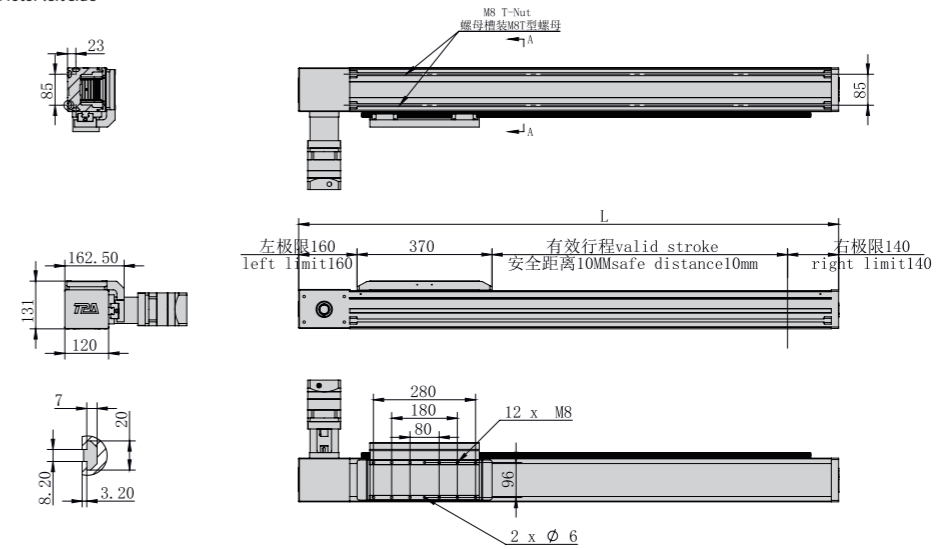

*不含电机和安装板重量 *Excluding motor and mounting plate weight

有效行程 Stroke	150	250	350	450	550	650	750	850	950	1050	1150	1250	1350	1450	1550	1650	1750	1850	1950	2050
L	830	930	1030	1130	1230	1330	1430	1530	1630	1730	1830	1930	2030	2130	2230	2330	2430	2530	2630	2730
KG	24.1	25.8	27.5	29.2	30.9	32.6	34.3	36	37.7	39.4	41.1	42.8	44.5	46.2	47.9	49.6	51.3	53	54.7	56.4

有效行程 Stroke	2150	2250	2350	2450	2550	2650	2750	2850	2950	3050	3150	3250	3350	3450	3550	3650	3750	3850	3950	4050
L	2830	2930	3030	3130	3230	3330	3430	3530	3630	3730	3830	3930	4030	4130	4230	4330	4430	4530	4630	4730
KG	58.1	59.8	61.5	63.2	64.9	66.6	68.3	70	71.7	73.4	75.1	76.8	78.5	80.2	81.9	83.6	85.3	87	88.7	90.4

DR 电机右侧 Motor right side

单位:Unit: mm

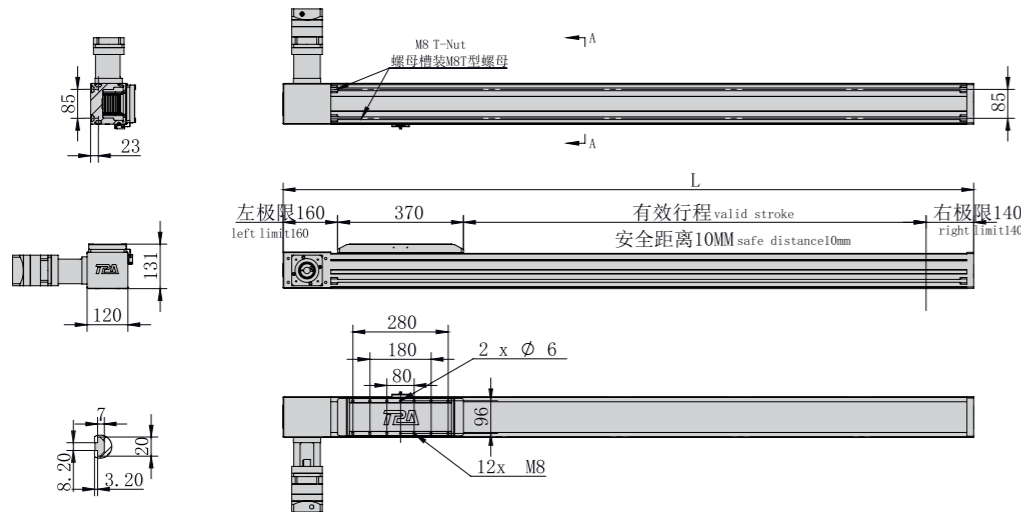

*不含电机和安装板重量 *Excluding motor and mounting plate weight

有效行程 Stroke	150	250	350	450	550	650	750	850	950	1050	1150	1250	1350	1450	1550	1650	1750	1850	1950	2050
L	830	930	1030	1130	1230	1330	1430	1530	1630	1730	1830	1930	2030	2130	2230	2330	2430	2530	2630	2730
KG	20.9	22.5	24.1	25.7	27.3	28.9	30.5	32.1	33.7	35.3	36.9	38.5	40.1	41.7	43.3	44.9	46.5	48.1	49.7	51.3

有效行程 Stroke	2150	2250	2350	2450	2550	2650	2750	2850	2950	3050	3150	3250	3350	3450	3550	3650	3750	3850	3950	4050
L	2830	2930	3030	3130	3230	3330	3430	3530	3630	3730	3830	3930	4030	4130	4230	4330	4430	4530	4630	4730
KG	52.9	54.5	56.1	57.7	59.3	60.9	62.5	64.1	65.7	67.3	68.9	70.5	72.1	73.7	75.3	76.9	78.5	80.1	81.7	83.3

DR 电机右侧 Motor right side

单位:Unit: mm

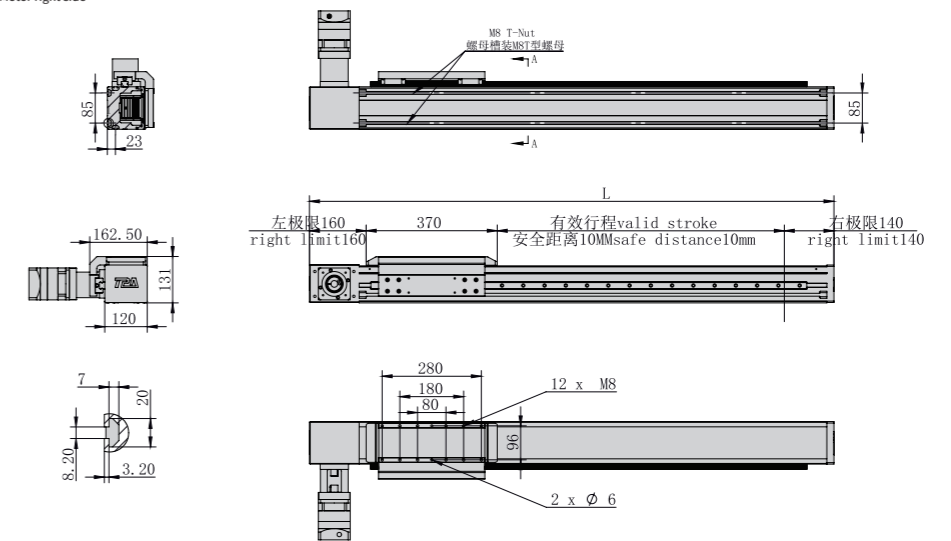

*不含电机和安装板重量 *Excluding motor and mounting plate weight

有效行程 Stroke	150	250	350	450	550	650	750	850	950	1050	1150	1250	1350	1450	1550	1650	1750	1850	1950	2050
L	830	930	1030	1130	1230	1330	1430	1530	1630	1730	1830	1930	2030	2130	2230	2330	2430	2530	2630	2730
KG	24.1	25.8	27.5	29.2	30.9	32.6	34.3	36	37.7	39.4	41.1	42.8	44.5	46.2	47.9	49.6	51.3	53	54.7	56.4

有效行程 Stroke	2150	2250	2350	2450	2550	2650	2750	2850	2950	3050	3150	3250	3350	3450	3550	3650	3750	3850	3950	4050
L	2830	2930	3030	3130	3230	3330	3430	3530	3630	3730	3830	3930	4030	4130	4230	4330	4430	4530	4630	4730
KG	58.1	59.8	61.5	63.2	64.9	66.6	68.3	70	71.7	73.4	75.1	76.8	78.5	80.2	81.9	83.6	85.3	87	88.7	90.4

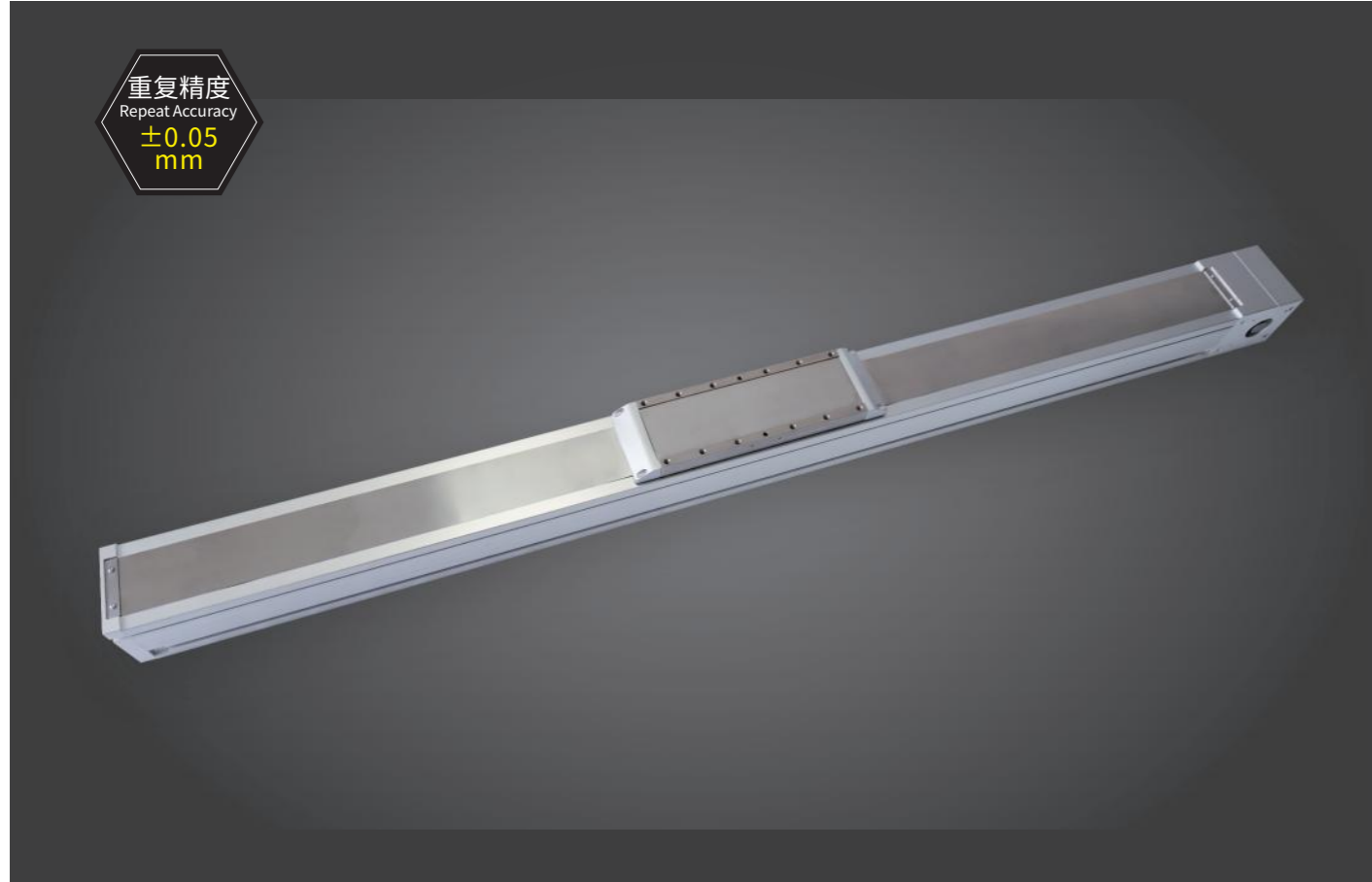

重复精度
Repeat Accuracy
±0.05
mm

此图仅供参考, 出货规格详见尺寸图面
This picture for reference only, specs details according with the drawing.

- 最大行程 Max Stroke: 5050mm
- 最高速度 Max Speed: 5000mm/s
- 马达容量 Motor Output: 750W
- 皮带宽度 Belt Width: 60mm
- 直线滑轨 Linear Guide: 35X29-1支

型号表达方式 Ordering method

TPA-OCB-140-256-L5050-DL-Y-P75B-N3-F

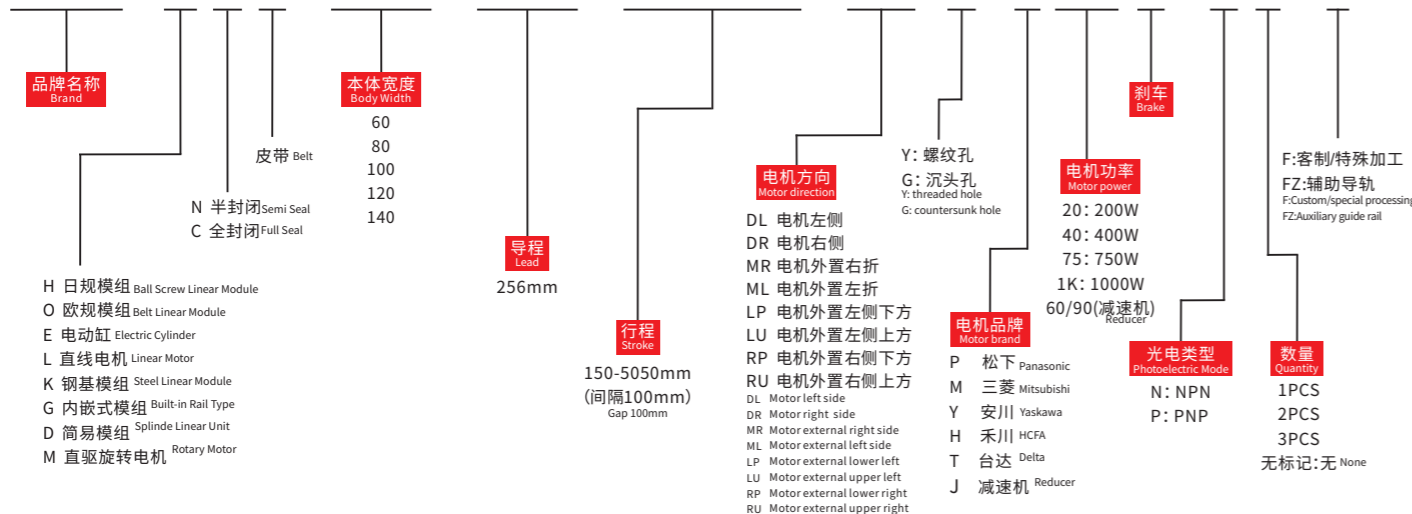

产品性能参数如下 Product performance parameters are as follows

规格 Spec	重复定位精度 (mm) Repeated positioning accuracy (mm)	±0.05					
	马达转速 (rpm/min) Rated Speed (rpm/min)	500	1000	1050	2000	2500	3000
	最高速度 (mm/s) Maximum speed (mm/s)	2133	4270	6400	8530	10630	12800
	最大可搬重量 Maximum Payload	水平使用 (kg) Horizontal (kg)					
部品 Parts	导程 (mm) lead (mm)	256					
	定格推力 (N) Rated thrust (N)	47					
	标准行程 (mm) Stroke pitch (mm)	150~5050mm/100 间隔 100 mm Pitch					
	AC伺服马达容量 (W) AC servo motor output (w)	750					
	皮带宽度 (mm) Belt Width (mm)	60					
	高刚性直线滑轨 (mm) High rigidity linear guide (mm)	35X29					
原点球型传感器 Home sensor	外挂 Outside	672 (NPN)					

※1 马达加减速设定0.4秒。
※1 Acceleration and deceleration value is set 0.4 second.

容许负载力矩表 N.m Allowable overhang

有效行程 Stroke	150-950	150-1450	150-1950	2050-2450	2550-5050
数量 Quantity	6	8	10	12	30

※滑台标准固定方式为下锁式, 使用M5后装螺帽固定。
※Standard mounting method is fix from the bottom, using the M5 bolt and nut.

容许负载力矩表 N.m Allowable overhang



导程 256 Lead	水平安装 Horizontal installation					侧面安装 Side installation				
	重量 Weight	线速度 Speed Maximum	A	B	C	重量 Weight	线速度 Speed Maximum	A	B	C
256 Lead	2kg	12800mm/s	-	-	-	2kg	12800mm/s	-	-	-
	6kg	10630mm/s	-	-	-	6kg	10630mm/s	-	-	-
	10kg	8530mm/s	-	-	-	10kg	8530mm/s	-	-	-
	15kg	6400mm/s	-	-	-	15kg	6400mm/s	-	-	-
	35kg	4270mm/s	-	-	-	35kg	4270mm/s	-	-	-
	45kg	2133mm/s	100	60	30	45kg	2133mm/s	30	60	100

搭配伺服马达一览表 Suitable motor brand

品牌 Brand	马达记号 Mark	刹车有无 Brake	马达容量 Motor capacity	电源电压 AC-Voltage	伺服马达型号 Servo motor model	驱动器型号 Driver Model
三菱 Mitsubishi	M	无刹车(水平式样) No brake (horizontal type)	750	220	HG-KR73	MR-J4-70A
松下 Panasonic	P	无刹车(水平式样) No brake (horizontal type)	750	220	MHMD082G1U	MBDHT3520
台达 Delta	T	无刹车(水平式样) No brake (horizontal type)	750	220	ECMA-C20807ES	ASD-B20721-B

速度-荷重曲线图 Acceleration-payload relationship

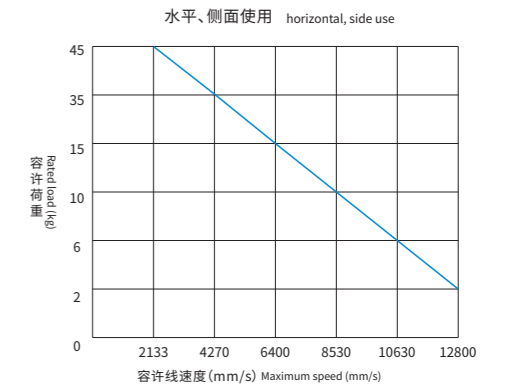

*以上使用条件请参考下方力矩表(最大值不可同时存在)。
*Please refer to the moment diagram below. (Do not reach all maximum value at same time.)

安装示意图 Installation diagram

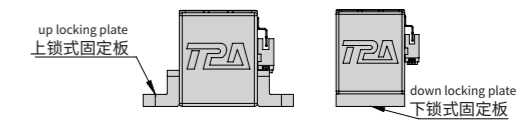

※上锁式固定板非标准品, 若有需求请另追加选购。
※Top fixing plate is optional.

静态容许负载惯量 Static loading moment

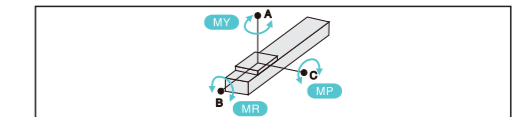

点	惯量 (N.m)
MY	47
MP	47
MR	20

*力矩表所表示的数据, 代表重心。
The torque value in the chart indicate the center of gravity.
*符合型录规范的正常试用下, 保证寿命为10000公里。
Operation life is 10,000km when the product is using under the specified conditions.
*侧吊使用无法套用标准规范, 如有需求请咨询我司业务。
The standard specification cannot be applied to the use of inverted crane.
Please consult our business if necessary.

电机左侧/电机右侧
Motor left side / Motor right side

DL 电机左侧 Motor left side

单位:Unit: mm

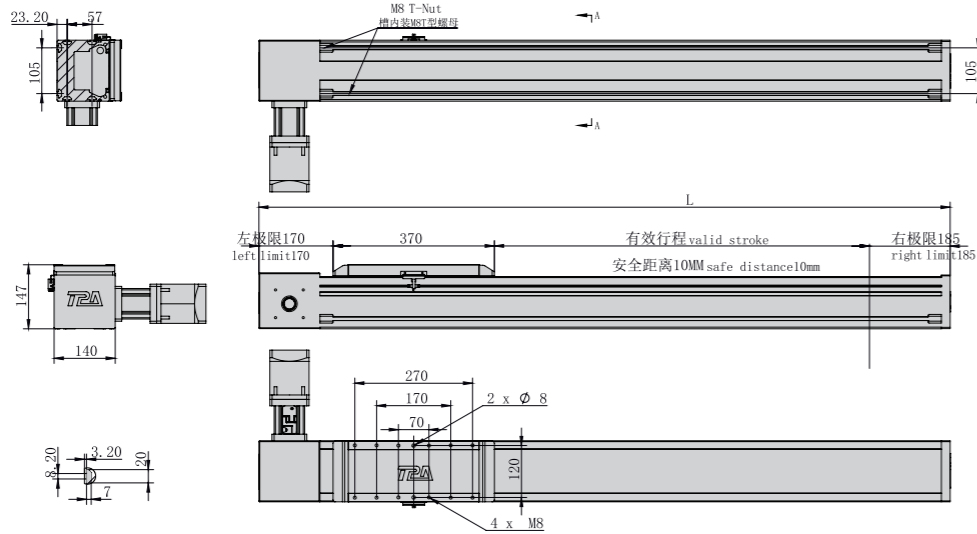

*不含电机和安装板重量 *Excluding motor and mounting plate weight

有效行程 Stroke	150	250	350	450	550	650	750	850	950	1050	1150	1250	1350	1450	1550	1650	1750	1850	1950	2050	2150	2250	2350	2450	2550
L	885	985	1085	1185	1285	1385	1485	1585	1685	1785	1885	1985	2085	2185	2285	2385	2485	2585	2685	2785	2885	2985	3085	3185	3285
KG	27.5	29.7	31.9	34.1	36.3	38.5	40.7	42.9	45.1	47.3	49.5	51.7	53.9	56.1	58.3	60.5	62.7	64.9	67.1	69.3	71.5	73.7	75.9	78.1	80.3

有效行程 Stroke	2650	2750	2850	2950	3050	3150	3250	3350	3450	3550	3650	3750	3850	3950	4050	4150	4250	4350	4450	4550	4650	4750	4850	4950	5050
L	3385	3485	3585	3685	3785	3885	3985	4085	4185	4285	4385	4485	4585	4685	4785	4885	4985	5085	5185	5285	5385	5485	5585	5685	5785
KG	82.5	84.7	86.9	89.1	91.3	93.5	95.7	97.9	100.1	102.3	104.5	106.7	108.9	111.1	113.3	115.5	117.7	119.9	122.1	124.3	126.5	128.7	130.9	133.1	135.3

OCB140-FZ 辅助导轨
OCB140-FZ Auxiliary guide rail

DL 电机左侧 Motor left side

单位:Unit: mm

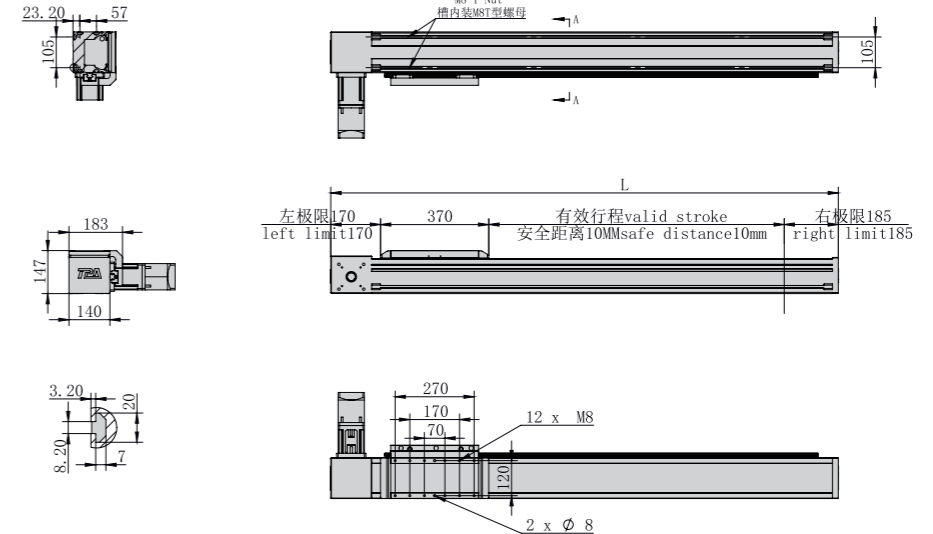

*不含电机和安装板重量 *Excluding motor and mounting plate weight

有效行程 Stroke	150	250	350	450	550	650	750	850	950	1050	1150	1250	1350	1450	1550	1650	1750	1850	1950	2050	2150	2250	2350	2450	2550
L	885	985	1085	1185	1285	1385	1485	1585	1685	1785	1885	1985	2085	2185	2285	2385	2485	2585	2685	2785	2885	2985	3085	3185	3285
KG	29.9	32.4	34.9	37.4	39.9	42.4	44.9	47.4	49.9	52.4	54.9	57.4	59.9	62.4	64.9	67.4	69.9	72.4	74.9	77.4	79.9	82.4	84.9	87.4	89.9

有效行程 Stroke	2650	2750	2850	2950	3050	3150	3250	3350	3450	3550	3650	3750	3850	3950	4050	4150	4250	4350	4450	4550	4650	4750	4850	4950	5050
L	3385	3485	3585	3685	3785	3885	3985	4085	4185	4285	4385	4485	4585	4685	4785	4885	4985	5085	5185	5285	5385	5485	5585	5685	5785
KG	92.4	94.9	97.4	99.9	102.4	104.9	107.4	109.9	112.4	114.9	117.4	119.9	122.4	124.9	127.4	129.9	132.4	134.9	137.4	139.9	142.4	144.9	147.4	149.9	152.4

DR 电机右侧 Motor right side

单位:Unit: mm

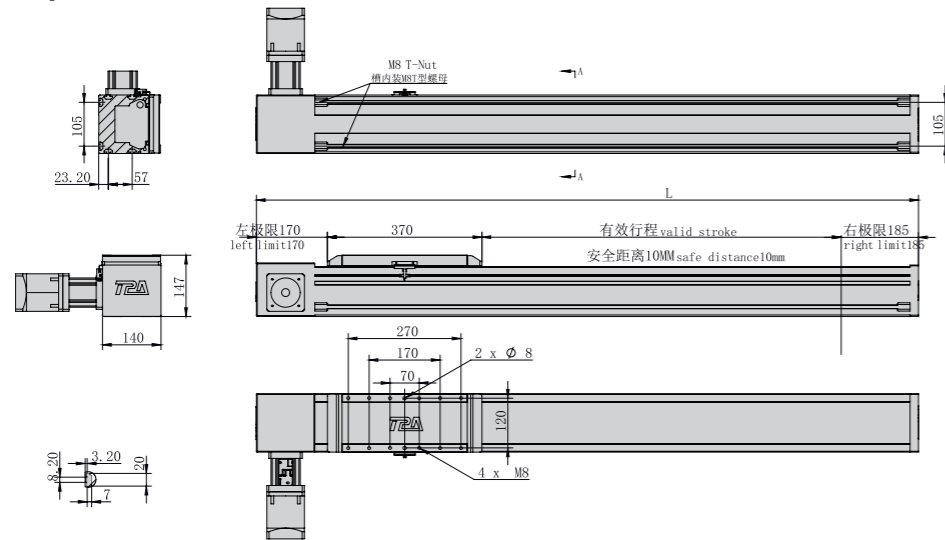

*不含电机和安装板重量 *Excluding motor and mounting plate weight

有效行程 Stroke	150	250	350	450	550	650	750	850	950	1050	1150	1250	1350	1450	1550	1650	1750	1850	1950	2050	2150	2250	2350	2450	2550
L	885	985	1085	1185	1285	1385	1485	1585	1685	1785	1885	1985	2085	2185	2285	2385	2485	2585	2685	2785	2885	2985	3085	3185	3285
KG	27.5	29.7	31.9	34.1	36.3	38.5	40.7	42.9	45.1	47.3	49.5	51.7	53.9	56.1	58.3	60.5	62.7	64.9	67.1	69.3	71.5	73.7	75.9	78.1	80.3

有效行程 Stroke	2650	2750	2850	2950	3050	3150	3250	3350	3450	3550	3650	3750	3850	3950	4050	4150	4250	4350	4450	4550	4650	4750	4850	4950	5050
L	3385	3485	3585	3685	3785	3885	3985	4085	4185	4285	4385	4485	4585	4685	4785	4885	4985	5085	5185	5285	5385	5485	5585	5685	5785
KG	82.5	84.7	86.9	89.1	91.3	93.5	95.7	97.9	100.1	102.3	104.5	106.7	108.9	111.1	113.3	115.5	117.7	119.9	122.1	124.3	126.5	128.7	130.9	133.1	135.3

DR 电机右侧 Motor right side

单位:Unit: mm

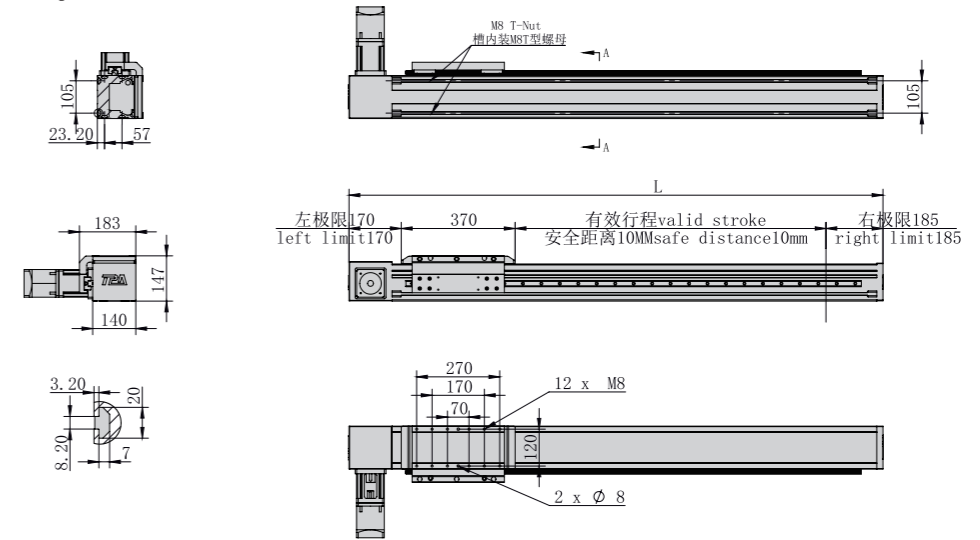

*不含电机和安装板重量 *Excluding motor and mounting plate weight

有效行程 Stroke	150	250	350	450	550	650	750	850	950	1050	1150	1250	1350	1450	1550	1650	1750	1850	1950	2050	2150	2250	2350	2450	2550
L	885	985	1085	1185	1285	1385	1485	1585	1685	1785	1885	1985	2085	2185	2285	2385	2485	2585	2685	2785	2885	2985	3085	3185	3285
KG	29.9	32.4	34.9	37.4	39.9	42.4	44.9	47.4	49.9	52.4	54.9	57.4	59.9	62.4	64.9	67.4	69.9	72.4	74.9	77.4	79.9	82.4	84.9	87.4	89.9

有效行程 Stroke	2650	2750	2850	2950	3050	3150	3250	3350	3450	3550	3650	3750	3850	3950	4050	4150	4250	4350	4450	4550	4650	4750	4850	4950	5050
L	3385	3485	3585	3685	3785	3885	3985	4085	4185	4285	4385	4485	4585	4685	4785	4885	4985	5085	5185	5285	5385	5485	5585	5685	5785
KG	92.4	94.9	97.4	99.9	102.4	104.9	107.4	109.9	112.4	114.9	117.4	119.9	122.4	124.9	127.4	129.9	132.4	134.9	137.4	139.9	142.4	144.9	147.4	149.9	152.4



此图仅供参考, 出货规格详见尺寸图面
This picture for reference only, specs details according with the drawing.

- 最大行程 Max Stroke: 3050mm
- 最高速度 Max Speed: 3900mm/s
- 马达容量 Motor Output: 400W
- 皮带宽度 Belt Width: 25mm
- 直线滑轨 Linear Guide: 15X12.5-1支

型号表达方式 Ordering method

TPA-OCB-60-140-L3050-MR-Y-P40B-N3-F

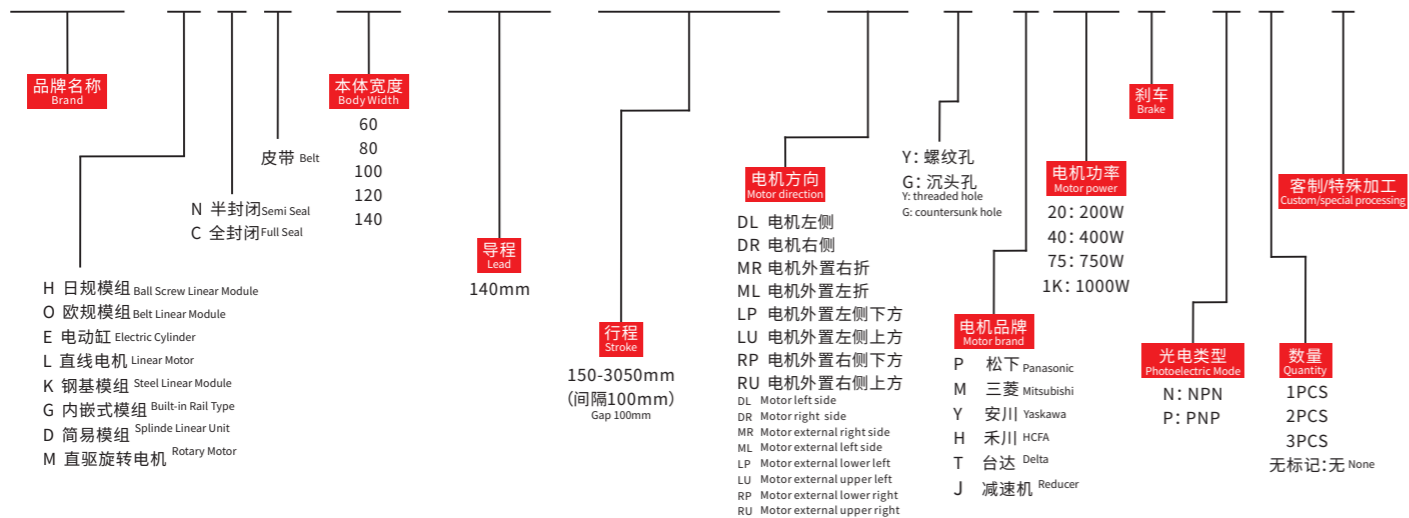

产品性能参数如下 Product performance parameters are as follows

规格 Spec	重复定位精度 (mm) Repeated positioning accuracy (mm)	±0.05			
	马达转速 (rpm) Rated Speed (rpm/min)	3:1	5:1	7:1	10:1
最大可搬重量 Maximum Payload	最高速度 (mm/s) Maximum speed (mm/s)	2333	1400	1000	700
	水平使用 (kg) Horizontal (kg)	32	47	58	63
	垂直使用 (kg) Vertical (kg) ^{※2}	11	17	18	20
	导程 (mm) lead (mm)	140			
部品 Parts	定格推力 (N) Rated thrust (N)	320			
	标准行程 (mm) Stroke pitch (mm) ^{※3}	150~3050mm/100 间隔 100 mm Pitch			
	AC伺服马达容量 (W) AC servo motor output (w)	400			
	皮带宽度 (mm) Belt Width (mm)	25			
	高刚性直线滑轨 (mm) High rigidity linear guide (mm)	15X12.5			
	原点感应器 Home sensor	外挂 Outside 672(NPN)			

※1 马达加速设定0.4秒。※1 Acceleration and deceleration value is set 0.4 second.
 ※2 垂直使用时, 若皮带断裂, 承载物会有掉落危险, 请注意。
 ※3 滑台未安装减速机时, 导程为110。※3 Lead is 110mm without gearbox.

速度-荷重曲线图 Acceleration-payload relationship

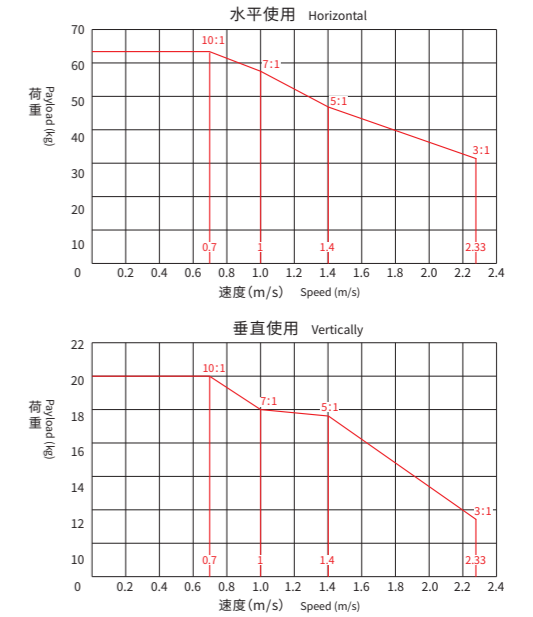

容许负载力矩表 N.m Allowable overhang

各行程M5后装螺帽数量 M5 nuts Qty.(by stroke)			
有效行程 Stroke	数量 Quantity	有效行程 Stroke	数量 Quantity
150-500	4	2600-3050	14

※滑台标准固定方式为下锁式, 使用M5后装螺帽固定。
 ※Standard mounting method is fix from the bottom, using the M5 bolt and nut.

安装示意图 Installation diagram

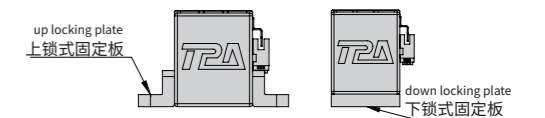

※上锁式固定板非标准品, 若有需求请另外追加选购。
 ※Top fixing plate is optional.

容许负载力矩表 N.m Allowable overhang

(单位Unit:mm)				
水平安装 Horizontal installation	A	B	C	
3:1	10kg	935	235	27
	20kg	405	90	18
	32kg	258	40	10
5:1	25kg	235	125	24
	35kg	610	75	15
	47kg	435	40	10
7:1	28kg	1285	130	25
	40kg	835	75	15
	58kg	535	35	10
10:1	30kg	1835	130	25
	45kg	1235	75	15
	63kg	785	35	10

(单位Unit:mm)				
侧面安装 Side mounting	A	B	C	
3:1	10kg	27	235	935
	20kg	18	90	405
	32kg	10	40	258
5:1	25kg	24	125	235
	35kg	15	75	610
	47kg	10	40	435
7:1	28kg	25	130	1285
	40kg	15	75	835
	58kg	10	35	535
10:1	30kg	25	130	1835
	45kg	15	75	1235
	63kg	10	35	785

(单位Unit:mm)				
垂直安装 Vertical installation	A	C		
3:1	3kg	885	885	
	6kg	435	435	
	11kg	285	285	
5:1	5kg	885	885	
	10kg	435	435	
	17kg	285	285	
7:1	6kg	885	885	
	12kg	435	435	
	18kg	285	285	
10:1	6kg	885	885	
	13kg	435	435	
	20kg	315	315	

静态容许负载惯量 Static loading moment

	(单位Unit:N.m)
MY	340
MP	340
MR	62

*力矩表所表示的数据, 代表重心。
 The torque value in the chart indicate the center of gravity.
 *符合型录规范的正常试用下, 保证寿命为10000公里。
 Operation life is 10,000km when the product is using under the specified conditions.
 *倒吊使用无法套用标准规范, 如有需求请咨询我司业务。
 The standard specification cannot be applied to the use of inverted crane. Please consult our business if necessary.



电机外置左侧/电机外置右侧
Motor external left side / Motor external right side

ML 电机外置左侧 Motor external left side

单位:Unit: mm

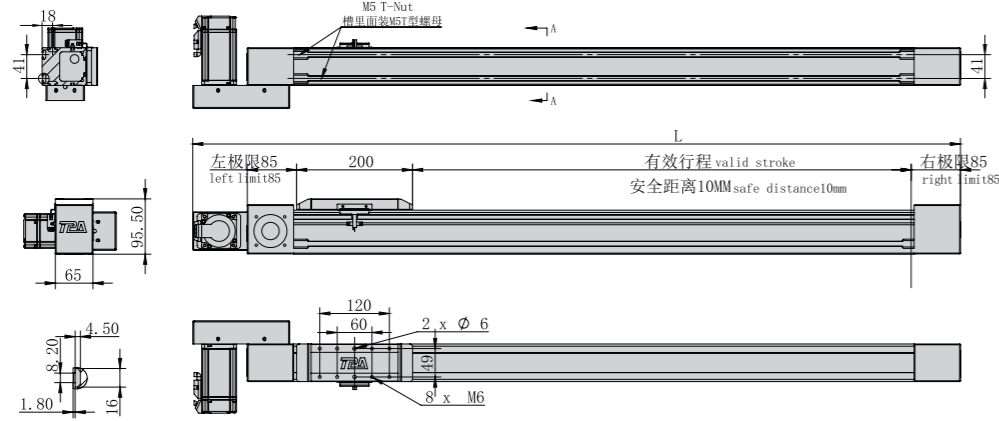

*不含电机和安装板重量 *Excluding motor and mounting plate weight

有效行程 Stroke	150	250	350	450	550	650	750	850	950	1050	1150	1250	1350	1450	1550
L	624	724	824	924	1024	1124	1224	1324	1424	1524	1624	1724	1824	1924	2024
KG	7.5	8	8.5	9	9.5	10	10.5	11	11.5	12	12.5	13	13.5	14	14.5

有效行程 Stroke	1650	1750	1850	1950	2050	2150	2250	2350	2450	2550	2650	2750	2850	2950	3050
L	2124	2224	2324	2424	2524	2624	2724	2824	2924	3024	3124	3224	3324	3424	3524
KG	15	15.5	16	16.5	17	17.5	18	18.5	19	19.5	20	20.5	21	21.5	22

电机外置左下/电机外置左上
Motor external lower left / Motor external upper left

LP 电机外置左下 Motor external lower left

单位:Unit: mm

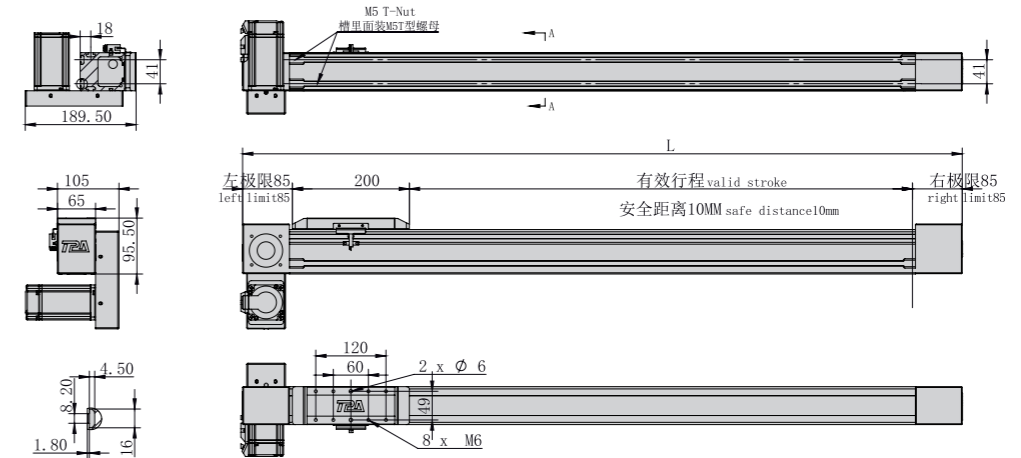

*不含电机和安装板重量 *Excluding motor and mounting plate weight

有效行程 Stroke	150	250	350	450	550	650	750	850	950	1050	1150	1250	1350	1450	1550
L	530	630	730	830	930	1030	1130	1230	1330	1430	1530	1630	1730	1830	1930
KG	7.5	8	8.5	9	9.5	10	10.5	11	11.5	12	12.5	13	13.5	14	14.5

有效行程 Stroke	1650	1750	1850	1950	2050	2150	2250	2350	2450	2550	2650	2750	2850	2950	3050
L	2030	2130	2230	2330	2430	2530	2630	2730	2830	2930	3030	3130	3230	3330	3430
KG	15	15.5	16	16.5	17	17.5	18	18.5	19	19.5	20	20.5	21	21.5	22

MR 电机外置右侧 Motor external right side

单位:Unit: mm

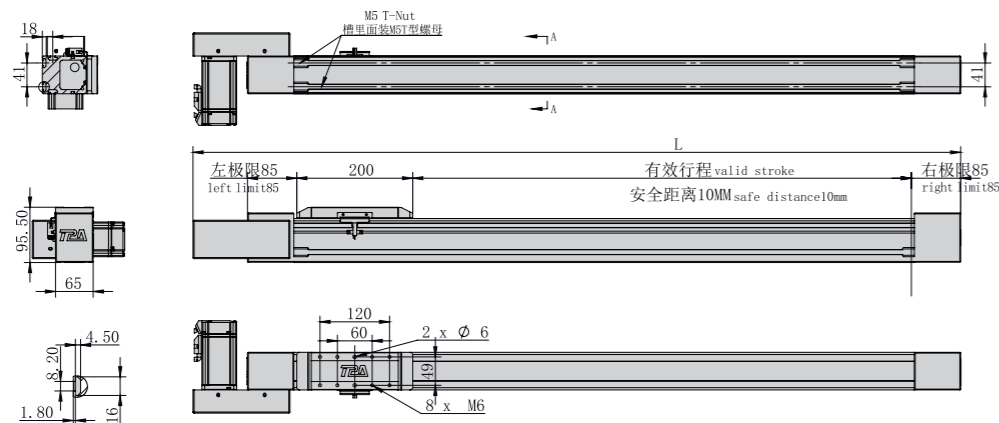

*不含电机和安装板重量 *Excluding motor and mounting plate weight

有效行程 Stroke	150	250	350	450	550	650	750	850	950	1050	1150	1250	1350	1450	1550
L	624	724	824	924	1024	1124	1224	1324	1424	1524	1624	1724	1824	1924	2024
KG	7.5	8	8.5	9	9.5	10	10.5	11	11.5	12	12.5	13	13.5	14	14.5

有效行程 Stroke	1650	1750	1850	1950	2050	2150	2250	2350	2450	2550	2650	2750	2850	2950	3050
L	2124	2224	2324	2424	2524	2624	2724	2824	2924	3024	3124	3224	3324	3424	3524
KG	15	15.5	16	16.5	17	17.5	18	18.5	19	19.5	20	20.5	21	21.5	22

LU 电机外置左上 Motor external upper left

单位:Unit: mm

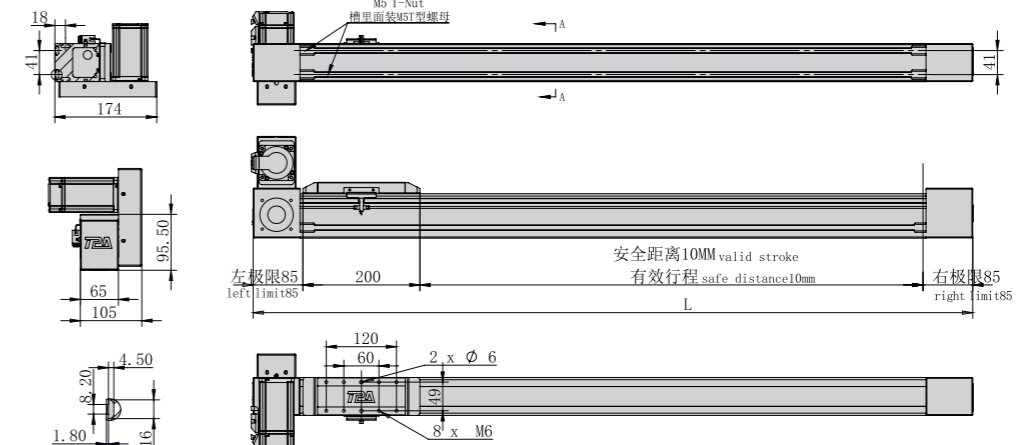

*不含电机和安装板重量 *Excluding motor and mounting plate weight

有效行程 Stroke	150	250	350	450	550	650	750	850	950	1050	1150	1250	1350	1450	1550
L	530	630	730	830	930	1030	1130	1230	1330	1430	1530	1630	1730	1830	1930
KG	7.5	8	8.5	9	9.5	10	10.5	11	11.5	12	12.5	13	13.5	14	14.5

有效行程 Stroke	1650	1750	1850	1950	2050	2150	2250	2350	2450	2550	2650	2750	2850	2950	3050
L	2030	2130	2230	2330	2430	2530	2630	2730	2830	2930	3030	3130	3230	3330	3430
KG	15	15.5	16	16.5	17	17.5	18	18.5	19	19.5	20	20.5	21	21.5	22



电机外置右下/电机外置右上
Motor external lower right / Motor external upper right

RP 电机外置右下 Motor external lower right

单位:Unit: mm

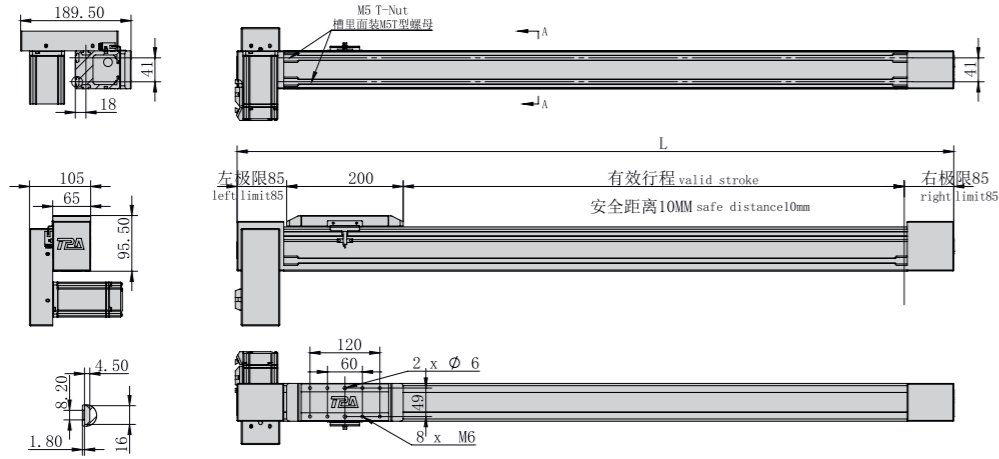

*不含电机和安装板重量 *Excluding motor and mounting plate weight

有效行程 Stroke	150	250	350	450	550	650	750	850	950	1050	1150	1250	1350	1450	1550
L	530	630	730	830	930	1030	1130	1230	1330	1430	1530	1630	1730	1830	1930
KG	7.5	8	8.5	9	9.5	10	10.5	11	11.5	12	12.5	13	13.5	14	14.5

有效行程 Stroke	1650	1750	1850	1950	2050	2150	2250	2350	2450	2550	2650	2750	2850	2950	3050
L	2030	2130	2230	2330	2430	2530	2630	2730	2830	2930	3030	3130	3230	3330	3430
KG	15	15.5	16	16.5	17	17.5	18	18.5	19	19.5	20	20.5	21	21.5	22

RU 电机外置右上 Motor external upper right

单位:Unit: mm

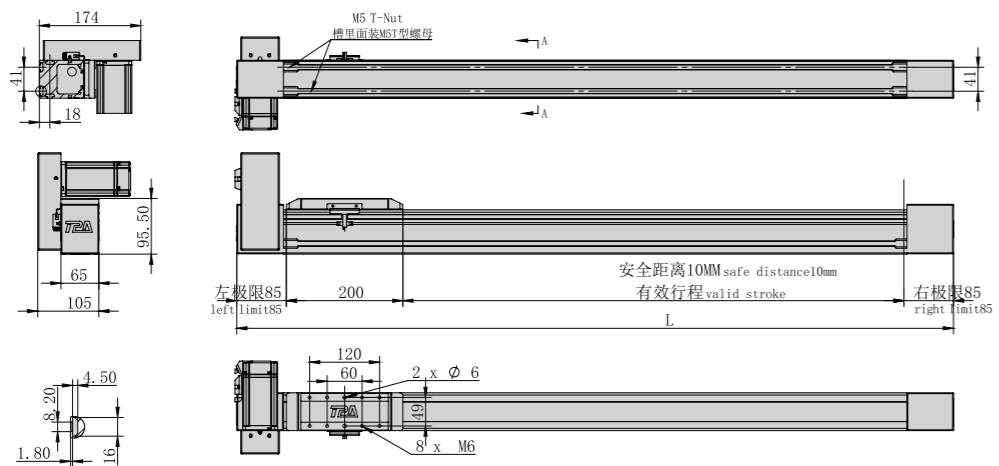

*不含电机和安装板重量 *Excluding motor and mounting plate weight

有效行程 Stroke	150	250	350	450	550	650	750	850	950	1050	1150	1250	1350	1450	1550
L	530	630	730	830	930	1030	1130	1230	1330	1430	1530	1630	1730	1830	1930
KG	7.5	8	8.5	9	9.5	10	10.5	11	11.5	12	12.5	13	13.5	14	14.5

有效行程 Stroke	1650	1750	1850	1950	2050	2150	2250	2350	2450	2550	2650	2750	2850	2950	3050
L	2030	2130	2230	2330	2430	2530	2630	2730	2830	2930	3030	3130	3230	3330	3430
KG	15	15.5	16	16.5	17	17.5	18	18.5	19	19.5	20	20.5	21	21.5	22

MEMO

ONB

OCB

参考资料
Reference
data



重复精度
Repeat Accuracy
±0.05
mm

此图仅供参考, 出货规格详见尺寸图面
This picture for reference only, specs details according with the drawing.

最大行程
Max Stroke 3050mm

最高速度
Max Speed 5000mm/s

马达容量
Motor Output 750W

皮带宽度
Belt Width 30mm

直线滑轨
Linear Guide 20X17.5-1支

型号表达方式 Ordering method

TPA-OCB-80-140-L3050-DL-Y-P40B-N3-F

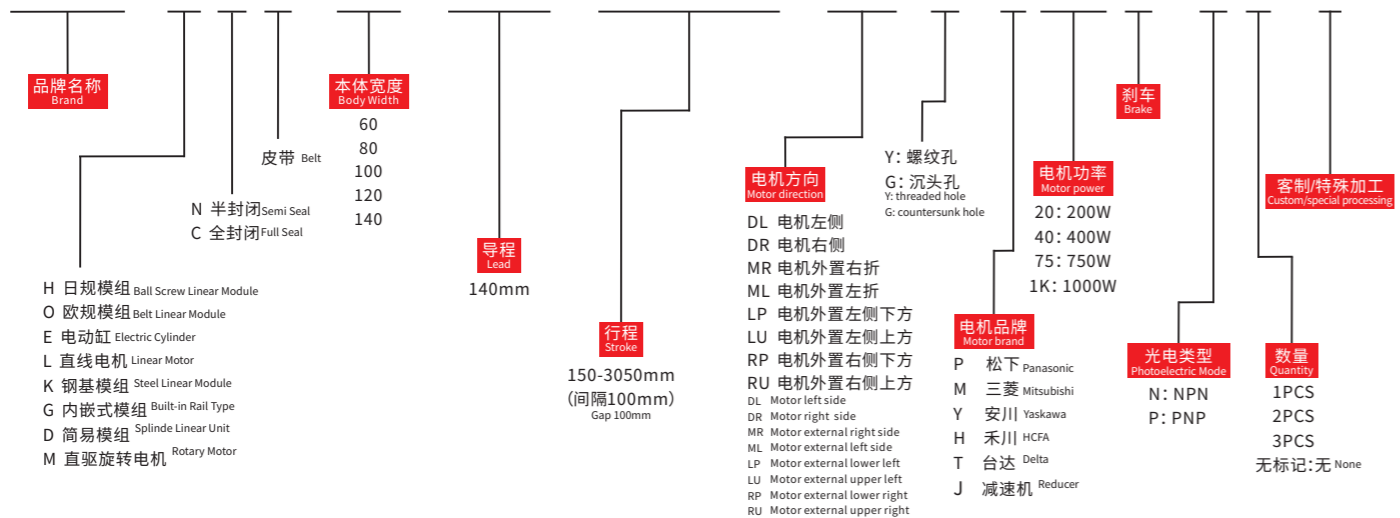

产品性能参数如下 Product performance parameters are as follows

规格 Spec	重复定位精度 (mm) Repeated positioning accuracy (mm)	±0.05		
	马达转速 (mm) Rated Speed (rpm/min)	5:1	7:1	10:1
	最高速度 (mm/s) Maximum speed (mm/s)	1400	1000	700
	最大可搬重量 Maximum Payload	水平使用 (kg) Horizontal (kg)	40	55
部品 Parts	垂直使用 (kg) Vertical (kg) ^{※2}	15	18	20
	导程 (mm) lead (mm)	140		
	定格推力 (N) Rated thrust (N)	320		
	标准行程 (mm) Stroke pitch (mm) ^{※3}	150~3050mm/100 间隔 100 mm Pitch		
	AC伺服马达容量 (W) AC servo motor output (w)	750		
皮带宽度 (mm) Belt Width(mm)	30			
高刚性直线滑轨 (mm) High rigidity linear guide(mm)	20X17.5			
原点感应器 Home sensor	外挂 Outside	672(NPN)		

※1 马达加速设定0.4秒。※1 Acceleration and deceleration value is set 0.4 second.
 ※2 垂直使用时,若皮带断裂,承载物会有掉落危险,请留意。
 ※2 Notice, if the belt breaks, the moving parts will fall when the application is vertical.
 ※3 滑台未安装减速机时,导程为110。※3 Lead is 110mm without gearbox.

速度-荷重曲线图 Acceleration-payload relationship

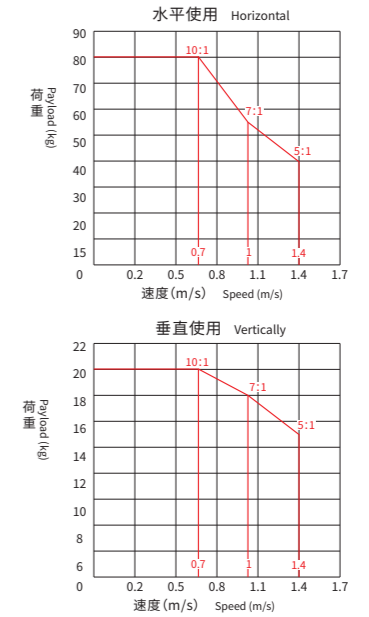

容许负载力矩表 N.m Allowable overhang

各行程M5后装螺帽数量 M5 nuts Qty.(by stroke)			
有效行程 Stroke	数量 Quantity	有效行程 Stroke	数量 Quantity
150-500	4	2600-3050	14

※滑台标准固定方式为下锁式,使用M5后装螺帽固定。
 ※Standard mounting method is fix from the bottom, using the M5 bolt and nut.

安装示意图 Installation diagram

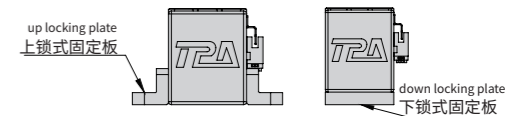

※上锁式固定板非标准品,若有需求请另外追加选购。
 ※Top fixing plate is optional.

容许负载力矩表 N.m Allowable overhang

(单位Unit:mm)				
水平安装 Horizontal installation	A	B	C	
5:1	10kg	908	288	48
	20kg	558	168	30
	40kg	408	118	23
7:1	25kg	758	168	30
	35kg	575	123	24
	55kg	420	93	20
10:1	28kg	908	148	28
	40kg	708	113	23
	80kg	558	83	18

(单位Unit:mm)				
侧面安装 Side mounting	A	B	C	
5:1	10kg	48	288	908
	20kg	30	168	608
	40kg	23	118	408
7:1	25kg	30	168	758
	35kg	23	118	583
	55kg	20	88	458
10:1	28kg	28	148	958
	40kg	23	113	758
	80kg	18	83	608

(单位Unit:mm)				
垂直安装 Vertical installation	A	C		
5:1	3kg	1258	1258	
	6kg	658	658	
	15kg	458	458	
7:1	5kg	608	608	
	10kg	488	488	
	18kg	408	408	
10:1	6kg	558	558	
	12kg	458	458	
	20kg	358	358	

静态容许负载惯量 Static loading moment

(单位Unit:N.m)	
MY	760
MP	760
MR	100

*力矩表所表示的数据,代表重心。
 The torque value in the chart indicate the center of gravity.
 *符合型录规范的正常试用下,保证寿命为10000公里。
 Operation life is 10,000km when the product is using under the specified conditions.
 *倒吊使用无法套用标准规范,如有需求请咨询我司业务。
 The standard specification cannot be applied to the use of inverted crane.
 Please consult our business if necessary.

电机外置左侧/电机外置右侧
Motor external left side / Motor external right side

ML 电机外置左侧 Motor external left side

单位:Unit: mm

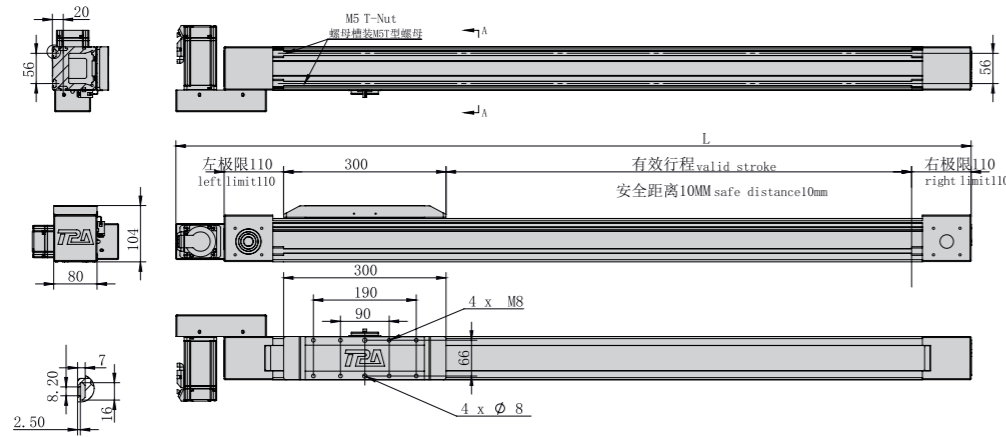

*不含电机和安装板重量 *Excluding motor and mounting plate weight

有效行程 Stroke	150	250	350	450	550	650	750	850	950	1050	1150	1250	1350	1450	1550
L	769	869	969	1069	1169	1269	1369	1469	1569	1669	1769	1869	1969	2069	2169
KG	10.9	11.8	12.7	13.6	14.5	15.4	16.3	17.2	18.1	19	19.9	20.8	21.7	22.6	23.5

有效行程 Stroke	1650	1750	1850	1950	2050	2150	2250	2350	2450	2550	2650	2750	2850	2950	3050
L	2269	2369	2469	2569	2669	2769	2869	2969	3069	3169	3269	3369	3469	3569	3669
KG	24.4	25.3	26.2	27.1	28	28.9	29.8	30.7	31.6	32.5	33.4	34.3	35.2	36.1	37

电机外置左下/电机外置左上
Motor external lower left / Motor external upper left

LP 电机外置左下 Motor external lower left

单位:Unit: mm

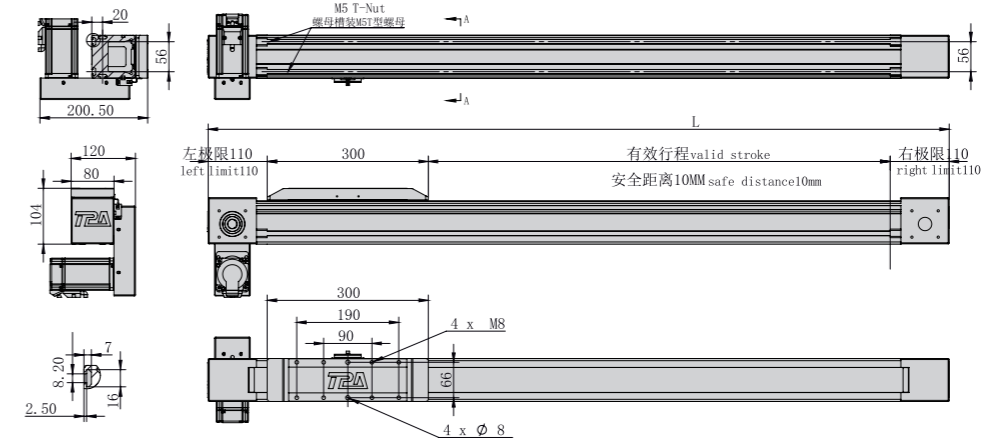

*不含电机和安装板重量 *Excluding motor and mounting plate weight

有效行程 Stroke	150	250	350	450	550	650	750	850	950	1050	1150	1250	1350	1450	1550
L	680	780	880	980	1080	1180	1280	1380	1480	1580	1680	1780	1880	1980	2080
KG	10.9	11.8	12.7	13.6	14.5	15.4	16.3	17.2	18.1	19	19.9	20.8	21.7	22.6	23.5

有效行程 Stroke	1650	1750	1850	1950	2050	2150	2250	2350	2450	2550	2650	2750	2850	2950	3050
L	2180	2280	2380	2480	2580	2680	2780	2880	2980	3080	3180	3280	3380	3480	3580
KG	24.4	25.3	26.2	27.1	28	28.9	29.8	30.7	31.6	32.5	33.4	34.3	35.2	36.1	37

MR 电机外置右侧 Motor external right side

单位:Unit: mm

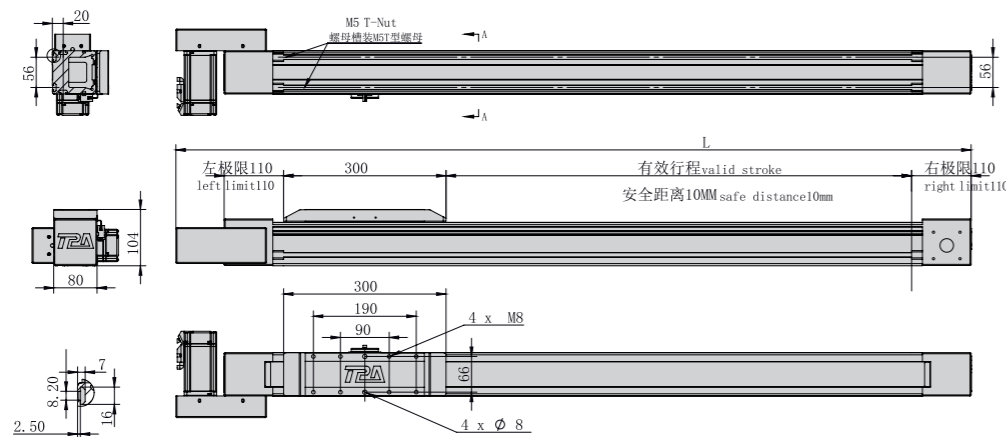

*不含电机和安装板重量 *Excluding motor and mounting plate weight

有效行程 Stroke	150	250	350	450	550	650	750	850	950	1050	1150	1250	1350	1450	1550
L	769	869	969	1069	1169	1269	1369	1469	1569	1669	1769	1869	1969	2069	2169
KG	10.9	11.8	12.7	13.6	14.5	15.4	16.3	17.2	18.1	19	19.9	20.8	21.7	22.6	23.5

有效行程 Stroke	1650	1750	1850	1950	2050	2150	2250	2350	2450	2550	2650	2750	2850	2950	3050
L	2269	2369	2469	2569	2669	2769	2869	2969	3069	3169	3269	3369	3469	3569	3669
KG	24.4	25.3	26.2	27.1	28	28.9	29.8	30.7	31.6	32.5	33.4	34.3	35.2	36.1	37

LU 电机外置左上 Motor external upper left

单位:Unit: mm

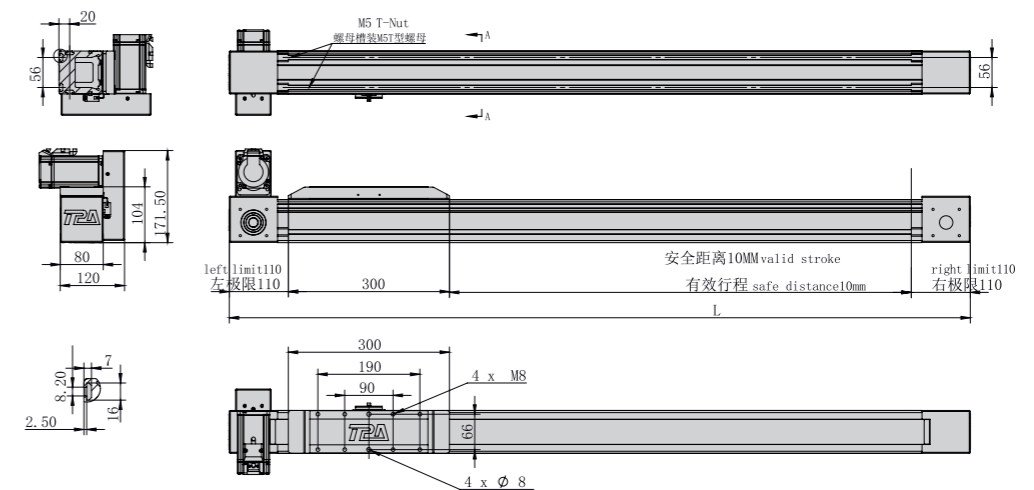

*不含电机和安装板重量 *Excluding motor and mounting plate weight

有效行程 Stroke	150	250	350	450	550	650	750	850	950	1050	1150	1250	1350	1450	1550
L	680	780	880	980	1080	1180	1280	1380	1480	1580	1680	1780	1880	1980	2080
KG	10.9	11.8	12.7	13.6	14.5	15.4	16.3	17.2	18.1	19	19.9	20.8	21.7	22.6	23.5

有效行程 Stroke	1650	1750	1850	1950	2050	2150	2250	2350	2450	2550	2650	2750	2850	2950	3050
L	2180	2280	2380	2480	2580	2680	2780	2880	2980	3080	3180	3280	3380	3480	3580
KG	24.4	25.3	26.2	27.1	28	28.9	29.8	30.7	31.6	32.5	33.4	34.3	35.2	36.1	37



电机外置右下/电机外置右上
Motor external lower right / Motor external upper right

RP 电机外置右下 Motor external lower right

单位:Unit: mm

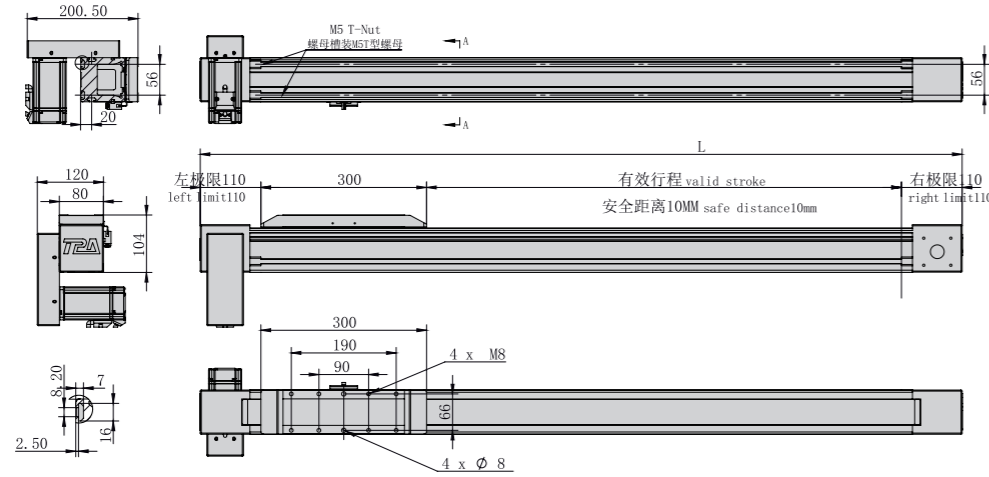

*不含电机和安装板重量 *Excluding motor and mounting plate weight

有效行程 Stroke	150	250	350	450	550	650	750	850	950	1050	1150	1250	1350	1450	1550
L	680	780	880	980	1080	1180	1280	1380	1480	1580	1680	1780	1880	1980	2080
KG	10.9	11.8	12.7	13.6	14.5	15.4	16.3	17.2	18.1	19	19.9	20.8	21.7	22.6	23.5

有效行程 Stroke	1650	1750	1850	1950	2050	2150	2250	2350	2450	2550	2650	2750	2850	2950	3050
L	2180	2280	2380	2480	2580	2680	2780	2880	2980	3080	3180	3280	3380	3480	3580
KG	24.4	25.3	26.2	27.1	28	28.9	29.8	30.7	31.6	32.5	33.4	34.3	35.2	36.1	37

RU 电机外置右上 Motor external upper right

单位:Unit: mm

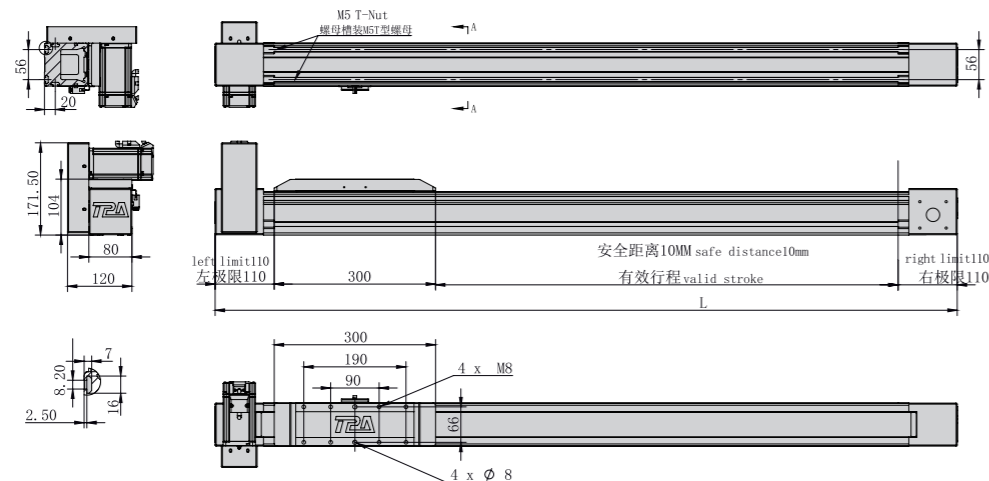

*不含电机和安装板重量 *Excluding motor and mounting plate weight

有效行程 Stroke	150	250	350	450	550	650	750	850	950	1050	1150	1250	1350	1450	1550
L	680	780	880	980	1080	1180	1280	1380	1480	1580	1680	1780	1880	1980	2080
KG	10.9	11.8	12.7	13.6	14.5	15.4	16.3	17.2	18.1	19	19.9	20.8	21.7	22.6	23.5

有效行程 Stroke	1650	1750	1850	1950	2050	2150	2250	2350	2450	2550	2650	2750	2850	2950	3050
L	2180	2280	2380	2480	2580	2680	2780	2880	2980	3080	3180	3280	3380	3480	3580
KG	24.4	25.3	26.2	27.1	28	28.9	29.8	30.7	31.6	32.5	33.4	34.3	35.2	36.1	37

MEMO

ONB

OCB

参考资料
Reference
data



重复精度
Repeat Accuracy
±0.05
mm

此图仅供参考, 出货规格详见尺寸图面
This picture for reference only, specs details according with the drawing.

- 最大行程 Max Stroke: 3050mm
- 最高速度 Max Speed: 5000mm/s
- 马达容量 Motor Output: 750W
- 皮带宽度 Belt Width: 30mm
- 直线滑轨 Linear Guide: 20X17.5-1支

型号表达方式 Ordering method

TPA-OCB-80S-140-L3050-DL-Y-P40B-N3-F

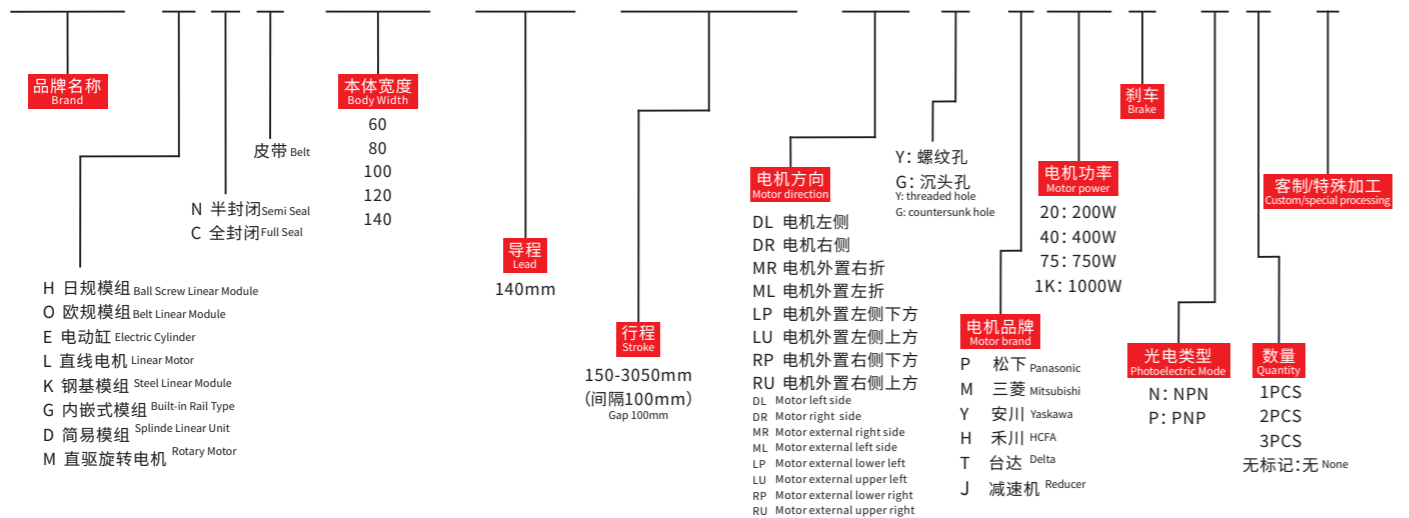

产品性能参数如下 Product performance parameters are as follows

规格 Spec	重复定位精度 (mm) Repeated positioning accuracy (mm)	±0.05		
	马达转速 (rpm) Rated Speed (rpm/min)	5:1	7:1	10:1
	最高速度 (mm/s) Maximum speed (mm/s)	1400	1000	700
	最大可搬重量 Maximum Payload	水平使用 (kg) Horizontal (kg)	30	45
垂直使用 (kg) Vertical (kg) ^{※2}		10	13	18
部品 Parts	导程 (mm) lead (mm)	140		
	定格推力 (N) Rated thrust (N)	320		
	标准行程 (mm) Stroke pitch (mm) ^{※3}	150~3050mm/100 间隔 100 mm Pitch		
	AC伺服马达容量 (W) AC servo motor output (w)	750		
	皮带宽度 (mm) Belt Width(mm)	30		
原点感应器 Home sensor	外挂 Outside	672(NPN)		
	高刚性直线滑轨 (mm) High rigidity linear guide(mm)	20X17.5		

※1 马达加速设定0.4秒。※1 Acceleration and deceleration value is set 0.4 second.
 ※2 垂直使用时, 若皮带断裂, 承载物会有掉落之危险, 请注意。
 ※2 Notice, if the belt breaks, the moving parts will fall when the application is vertical.
 ※3 滑台未安装减速机时, 导程为110。※3 Lead is 110mm without gearbox.

速度-荷重曲线图 Acceleration-payload relationship

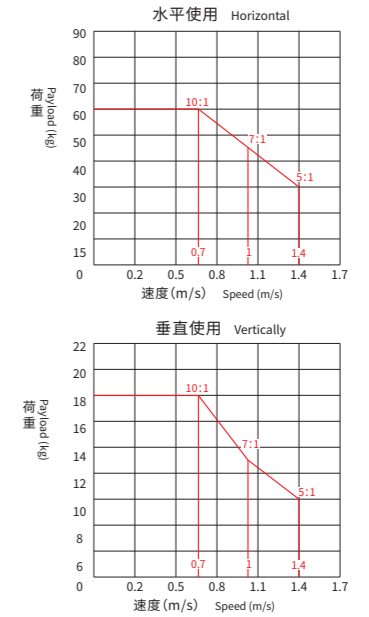

容许负载力矩表 N.m Allowable overhang

各行程M5后装螺帽数量 M5 nuts Qty.(by stroke)			
有效行程 Stroke	数量 Quantity	有效行程 Stroke	数量 Quantity
150-500	4	2600-3050	14

※滑台标准固定方式为下锁式, 使用M5后装螺帽固定。
 ※Standard mounting method is fix from the bottom, using the M5 bolt and nut.

安装示意图 Installation diagram

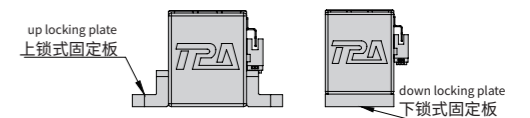

※上锁式固定板非标准品, 若有需求请另外加选购。
 ※Top fixing plate is optional.

容许负载力矩表 N.m Allowable overhang

水平安装 Horizontal installation	(单位Unit:mm)		
	A	B	C
5:1	10kg	908	288
	15kg	558	168
	30kg	408	118
7:1	15kg	758	168
	25kg	575	123
	45kg	420	93
10:1	18kg	908	148
	30kg	708	113
	60kg	558	83

侧面安装 Side mounting	(单位Unit:mm)		
	A	B	C
5:1	10kg	48	288
	15kg	30	168
	30kg	23	118
7:1	15kg	30	168
	25kg	23	118
	45kg	20	88
10:1	18kg	28	148
	30kg	23	113
	60kg	18	83

垂直安装 Vertical installation	(单位Unit:mm)		
	A	B	C
5:1	3kg	1258	1258
	6kg	658	658
	13kg	458	458
7:1	5kg	608	608
	8kg	488	488
	15kg	408	408
10:1	5kg	558	558
	10kg	458	458
	18kg	358	358

静态容许负载惯量 Static loading moment

(单位Unit:N.m)	
MY	760
MP	760
MR	100

*力矩表所表示的数据, 代表重心。
 The torque value in the chart indicate the center of gravity.
 *符合型录规范的正常试用下, 保证寿命为10000公里。
 Operation life is 10,000km when the product is using under the specified conditions.
 *倒吊使用无法套用标准规范, 如有需求请咨询我司业务。
 The standard specification cannot be applied to the use of inverted crane.
 Please consult our business if necessary.

电机外置左侧/电机外置右侧
Motor external left side / Motor external right side

ML 电机外置左侧 Motor external left side

单位:Unit: mm

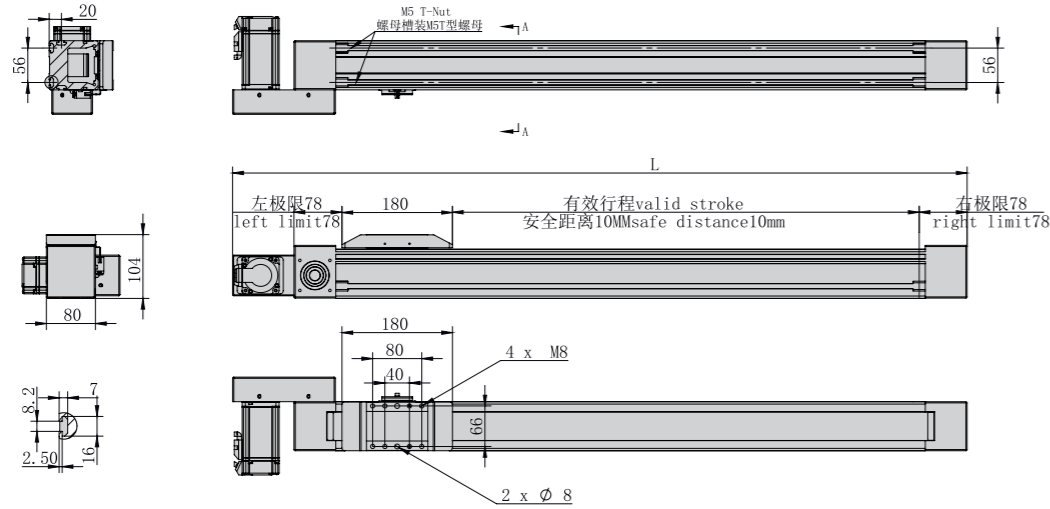

*不含电机和安装板重量 *Excluding motor and mounting plate weight

有效行程 Stroke	150	250	350	450	550	650	750	850	950	1050	1150	1250	1350	1450	1550
L	596	696	796	896	996	1096	1196	1296	1396	1496	1596	1696	1796	1896	1996
KG	10.1	11	11.9	12.8	13.7	14.6	15.5	16.4	17.3	18.2	19.1	20	20.9	21.8	22.7

有效行程 Stroke	1650	1750	1850	1950	2050	2150	2250	2350	2450	2550	2650	2750	2850	2950	3050
L	2096	2196	2296	2396	2496	2596	2696	2796	2896	2996	3096	3196	3296	3396	3496
KG	23.6	24.5	25.4	26.3	27.2	28.1	29	29.9	30.8	31.7	32.6	33.5	34.4	35.3	36.2

电机外置左下/电机外置左上
Motor external lower left / Motor external upper left

LP 电机外置左下 Motor external lower left

单位:Unit: mm

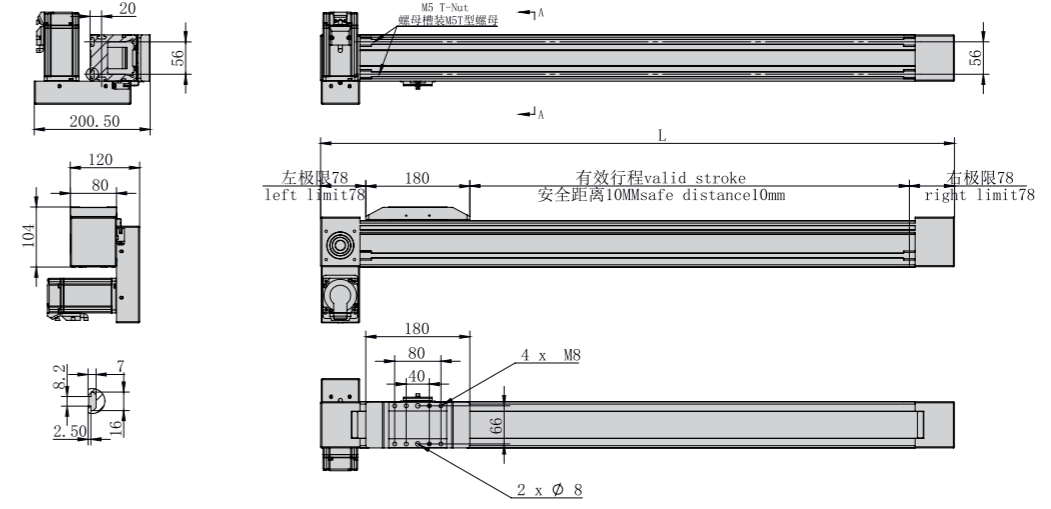

*不含电机和安装板重量 *Excluding motor and mounting plate weight

有效行程 Stroke	150	250	350	450	550	650	750	850	950	1050	1150	1250	1350	1450	1550
L	496	596	696	796	896	996	1096	1196	1296	1396	1496	1596	1696	1796	1896
KG	10.1	11	11.9	12.8	13.7	14.6	15.5	16.4	17.3	18.2	19.1	20	20.9	21.8	22.7

有效行程 Stroke	1650	1750	1850	1950	2050	2150	2250	2350	2450	2550	2650	2750	2850	2950	3050
L	1996	2096	2196	2296	2396	2496	2596	2696	2796	2896	2996	3096	3196	3296	3396
KG	23.6	24.5	25.4	26.3	27.2	28.1	29	29.9	30.8	31.7	32.6	33.5	34.4	35.3	36.2

MR 电机外置右侧 Motor external right side

单位:Unit: mm

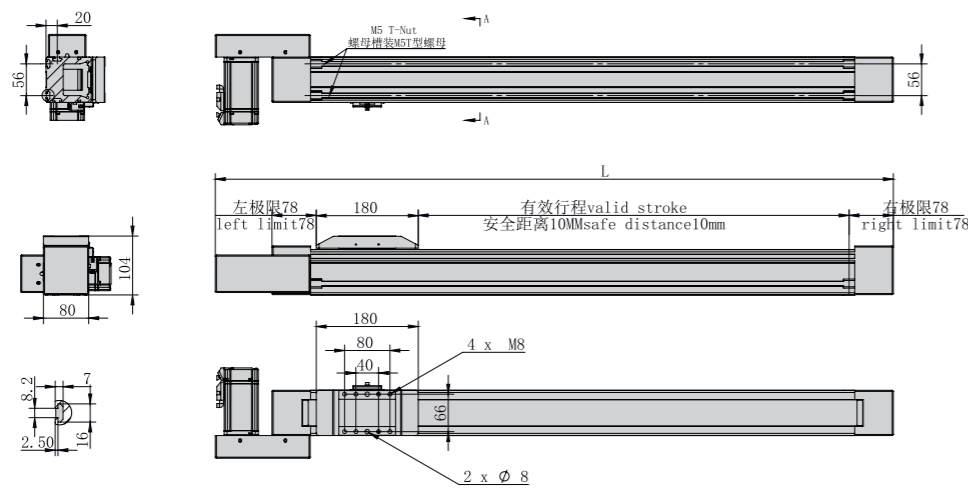

*不含电机和安装板重量 *Excluding motor and mounting plate weight

有效行程 Stroke	150	250	350	450	550	650	750	850	950	1050	1150	1250	1350	1450	1550
L	596	696	796	896	996	1096	1196	1296	1396	1496	1596	1696	1796	1896	1996
KG	10.1	11	11.9	12.8	13.7	14.6	15.5	16.4	17.3	18.2	19.1	20	20.9	21.8	22.7

有效行程 Stroke	1650	1750	1850	1950	2050	2150	2250	2350	2450	2550	2650	2750	2850	2950	3050
L	2096	2196	2296	2396	2496	2596	2696	2796	2896	2996	3096	3196	3296	3396	3496
KG	23.6	24.5	25.4	26.3	27.2	28.1	29	29.9	30.8	31.7	32.6	33.5	34.4	35.3	36.2

LU 电机外置左上 Motor external upper left

单位:Unit: mm

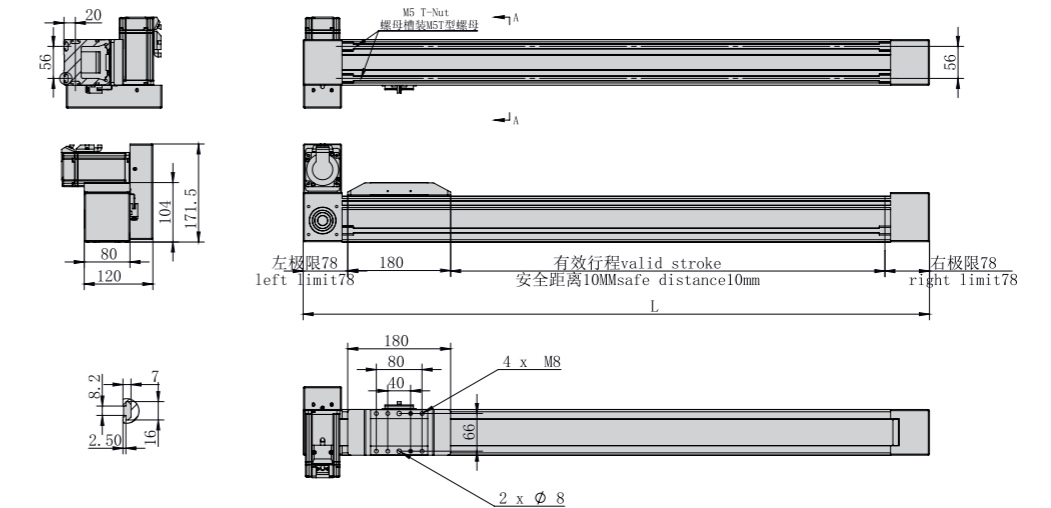

*不含电机和安装板重量 *Excluding motor and mounting plate weight

有效行程 Stroke	150	250	350	450	550	650	750	850	950	1050	1150	1250	1350	1450	1550
L	496	596	696	796	896	996	1096	1196	1296	1396	1496	1596	1696	1796	1896
KG	10.1	11	11.9	12.8	13.7	14.6	15.5	16.4	17.3	18.2	19.1	20	20.9	21.8	22.7

有效行程 Stroke	1650	1750	1850	1950	2050	2150	2250	2350	2450	2550	2650	2750	2850	2950	3050
L	1996	2096	2196	2296	2396	2496	2596	2696	2796	2896	2996	3096	3196	3296	3396
KG	23.6	24.5	25.4	26.3	27.2	28.1	29	29.9	30.8	31.7	32.6	33.5	34.4	35.3	36.2



电机外置右下/电机外置右上
Motor external lower right / Motor external upper right

RP 电机外置右下 Motor external lower right

单位:Unit: mm

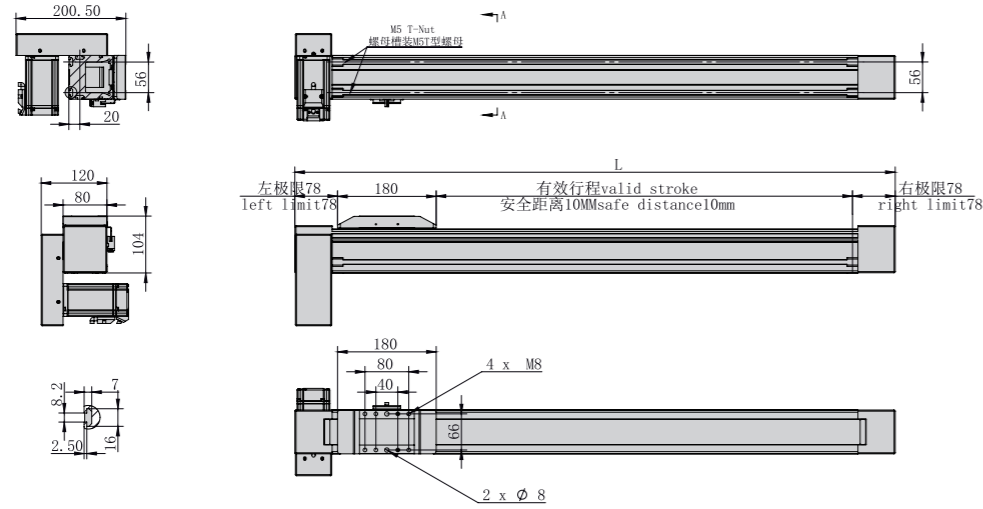

*不含电机和安装板重量 *Excluding motor and mounting plate weight

有效行程 Stroke	150	250	350	450	550	650	750	850	950	1050	1150	1250	1350	1450	1550
L	496	596	696	796	896	996	1096	1196	1296	1396	1496	1596	1696	1796	1896
KG	10.1	11	11.9	12.8	13.7	14.6	15.5	16.4	17.3	18.2	19.1	20	20.9	21.8	22.7

有效行程 Stroke	1650	1750	1850	1950	2050	2150	2250	2350	2450	2550	2650	2750	2850	2950	3050
L	1996	2096	2196	2296	2396	2496	2596	2696	2796	2896	2996	3096	3196	3296	3396
KG	23.6	24.5	25.4	26.3	27.2	28.1	29	29.9	30.8	31.7	32.6	33.5	34.4	35.3	36.2

RU 电机外置右上 Motor external upper right

单位:Unit: mm

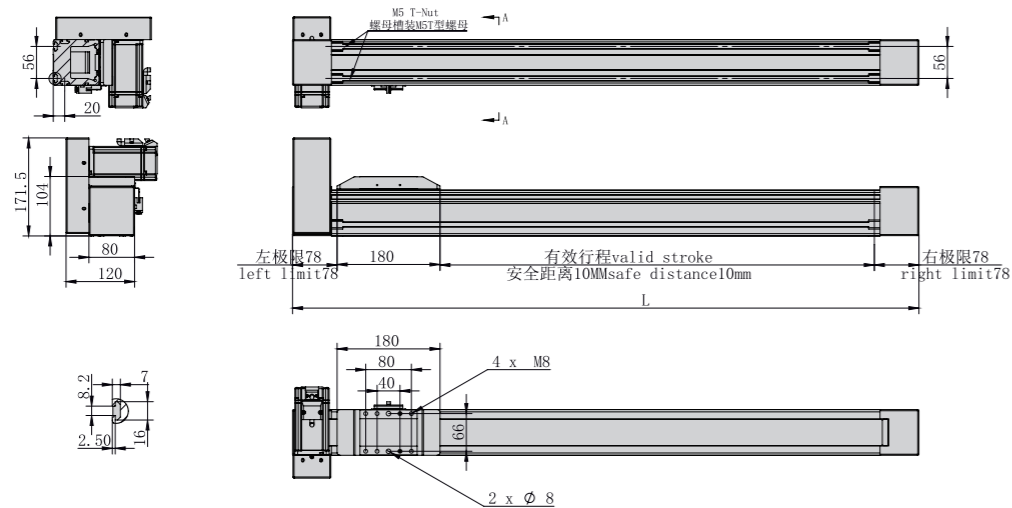

*不含电机和安装板重量 *Excluding motor and mounting plate weight

有效行程 Stroke	150	250	350	450	550	650	750	850	950	1050	1150	1250	1350	1450	1550
L	496	596	696	796	896	996	1096	1196	1296	1396	1496	1596	1696	1796	1896
KG	10.1	11	11.9	12.8	13.7	14.6	15.5	16.4	17.3	18.2	19.1	20	20.9	21.8	22.7

有效行程 Stroke	1650	1750	1850	1950	2050	2150	2250	2350	2450	2550	2650	2750	2850	2950	3050
L	1996	2096	2196	2296	2396	2496	2596	2696	2796	2896	2996	3096	3196	3296	3396
KG	23.6	24.5	25.4	26.3	27.2	28.1	29	29.9	30.8	31.7	32.6	33.5	34.4	35.3	36.2

MEMO

ONB

OCB

参考资料
Reference
data

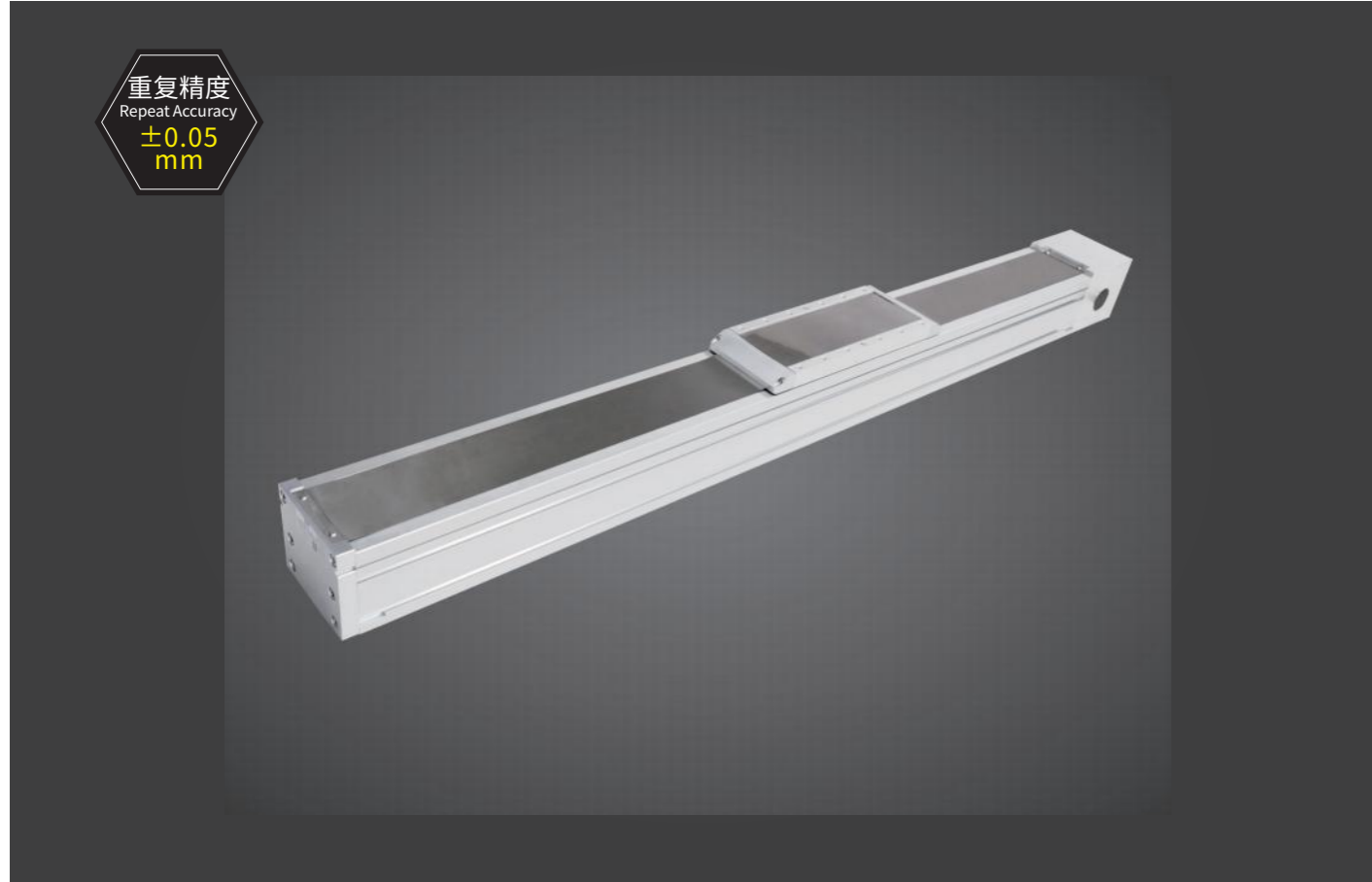

重复精度
Repeat Accuracy
±0.05
mm

此图仅供参考, 出货规格详见尺寸图面
This picture for reference only, specs details according with the drawing.

- 最大行程 Max Stroke: 3050mm
- 最高速度 Max Speed: 5000mm/s
- 马达容量 Motor Output: 750W
- 皮带宽度 Belt Width: 50mm
- 直线滑轨 Linear Guide: 30X23-1支

型号表达方式 Ordering method

TPA-OCB-100-192-L3050-MR-Y-P75B-N3-F

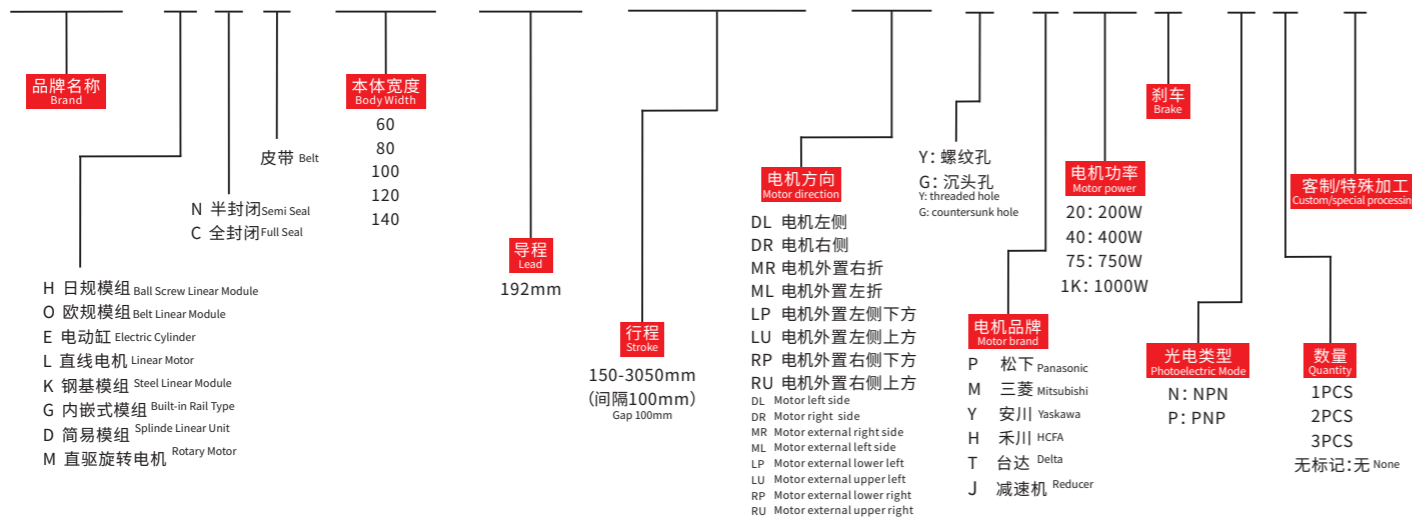

产品性能参数如下 Product performance parameters are as follows

规格 Spec	重复定位精度 (mm) Repeated positioning accuracy (mm)	±0.05			
	马达转速 (rpm) Rated Speed (rpm/min)	5:1	7:1	10:1	
	最高速度 (mm/s) Maximum speed (mm/s)	1920	1371	960	
	最大可搬重量 Maximum Payload	水平使用 (kg) Horizontal (kg)	50	70	90
部品 Parts		垂直使用 (kg) Vertical (kg) ※2	20	40	50
	导程 (mm) lead (mm)	192			
	定格推力 (N) Rated thrust (N)	420			
	标准行程 (mm) Stroke pitch (mm) ※3	150~3050mm/100 间隔 100 mm Pitch			
	AC伺服马达容量 (W) AC servo motor output (w)	750			
	皮带宽度 (mm) Belt Width (mm)	50			
	高刚性直线滑轨 (mm) High rigidity linear guide (mm)	30X23			
	原点感应器 Home sensor	外挂 Outside	672 (NPN)		

※1 马达加速设定0.4秒。※1 Acceleration and deceleration value is set 0.4 second.
 ※2 垂直使用时, 若皮带断裂, 承载物会有掉落之危险, 请注意。
 ※2 Notice, if the belt breaks, the moving parts will fall when the application is vertical.
 ※3 滑台未安装减速机时, 导程为110。※3 Lead is 110mm without gearbox.

速度-荷重曲线图 Acceleration-payload relationship

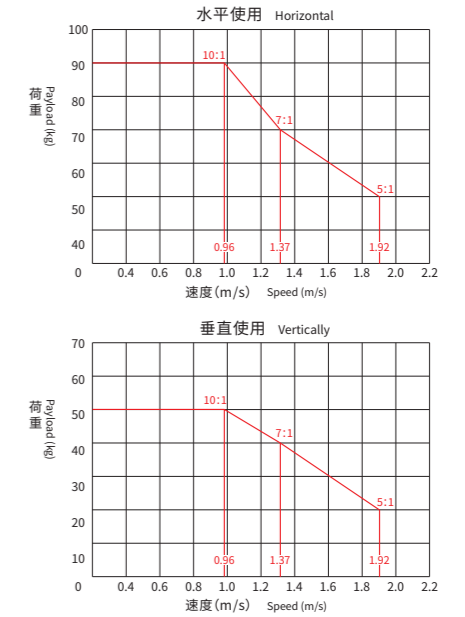

容许负载力矩表 N.m Allowable overhang

各行程M5后装螺帽数量 M5 nuts Qty.(by stroke)			
有效行程 Stroke	数量 Quantity	有效行程 Stroke	数量 Quantity
150-500	4	2600-3050	14

※滑台标准固定方式为下锁式, 使用M5后装螺帽固定。
 ※Standard mounting method is fix from the bottom, using the M5 bolt and nut.

安装示意图 Installation diagram

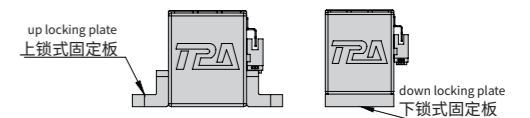

※上锁式固定板非标准品, 若有需求请另外追加选购。
 ※Top fixing plate is optional.

容许负载力矩表 N.m Allowable overhang

速度比	水平安装 Horizontal installation			侧面安装 Side mounting			垂直安装 Vertical installation		
	A	B	C	A	B	C	A	B	C
5:1	25kg	908	288	48	288	908	5kg	1258	1258
	35kg	558	168	30	168	608	10kg	658	658
	50kg	408	118	23	118	408	20kg	458	458
7:1	28kg	758	168	30	168	758	6kg	608	608
	40kg	575	123	24	118	583	12kg	488	488
	70kg	420	93	20	88	458	40kg	408	408
10:1	30kg	908	148	28	148	958	6kg	558	558
	45kg	708	113	23	113	758	13kg	458	458
	90kg	558	83	18	83	608	50kg	358	358

静态容许负载惯量 Static loading moment

惯量	容许值 (单位Unit:N.m)
MY	900
MP	900
MR	200

*力矩表所表示的数据, 代表重心。
 The torque value in the chart indicate the center of gravity.
 *符合型录规范的正常试用下, 保证寿命为10000公里。
 Operation life is 10,000km when the product is using under the specified conditions.
 *倒吊使用无法套用标准规范, 如有需求请咨询我司业务。
 The standard specification cannot be applied to the use of inverted crane. Please consult our business if necessary.



电机外置左侧/电机外置右侧
Motor external left side / Motor external right side

ML 电机外置左侧 Motor external left side

单位:Unit: mm

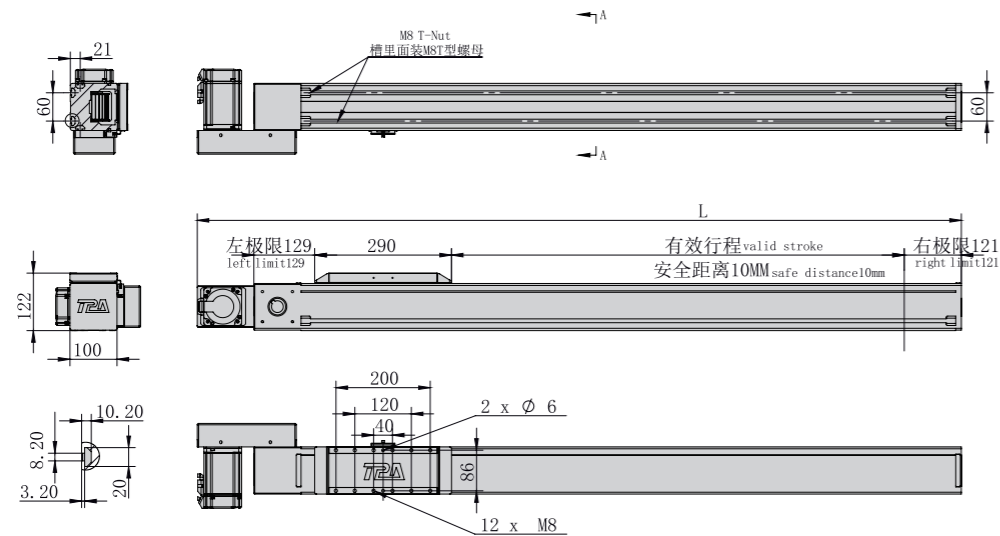

*不含电机和安装板重量 *Excluding motor and mounting plate weight

有效行程 Stroke	150	250	350	450	550	650	750	850	950	1050	1150	1250	1350	1450	1550
L	820	920	1020	1120	1220	1320	1420	1520	1620	1720	1820	1920	2020	2120	2220
KG	16	17.5	19	20.5	22	23.5	25	26.5	28	29.5	31	32.5	34	35.5	37

有效行程 Stroke	1650	1750	1850	1950	2050	2150	2250	2350	2450	2550	2650	2750	2850	2950	3050
L	2320	2420	2520	2620	2720	2820	2920	3020	3120	3220	3320	3420	3520	3620	3720
KG	38.5	40	41.5	43	44.5	46	47.5	49	50.5	52	53.5	55	56.5	58	59.5

电机外置左下/电机外置左上
Motor external lower left / Motor external upper left

LP 电机外置左下 Motor external lower left

单位:Unit: mm

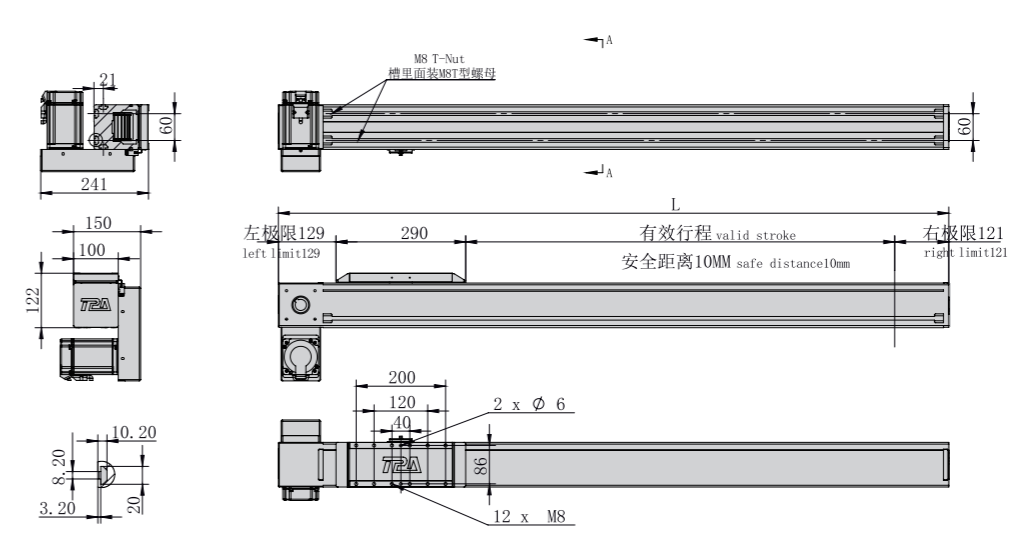

*不含电机和安装板重量 *Excluding motor and mounting plate weight

有效行程 Stroke	150	250	350	450	550	650	750	850	950	1050	1150	1250	1350	1450	1550
L	700	800	900	1000	1100	1200	1300	1400	1500	1600	1700	1800	1900	2000	2100
KG	16	17.5	19	20.5	22	23.5	25	26.5	28	29.5	31	32.5	34	35.5	37

有效行程 Stroke	1650	1750	1850	1950	2050	2150	2250	2350	2450	2550	2650	2750	2850	2950	3050
L	2200	2300	2400	2500	2600	2700	2800	2900	3000	3100	3200	3300	3400	3500	3600
KG	38.5	40	41.5	43	44.5	46	47.5	49	50.5	52	53.5	55	56.5	58	59.5

MR 电机外置右侧 Motor external right side

单位:Unit: mm

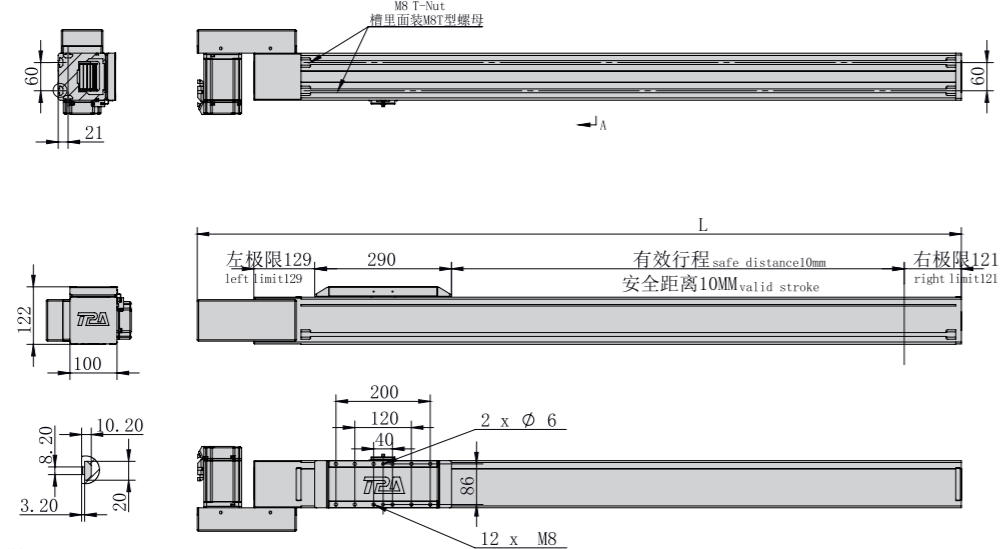

*不含电机和安装板重量 *Excluding motor and mounting plate weight

有效行程 Stroke	150	250	350	450	550	650	750	850	950	1050	1150	1250	1350	1450	1550
L	820	920	1020	1120	1220	1320	1420	1520	1620	1720	1820	1920	2020	2120	2220
KG	16	17.5	19	20.5	22	23.5	25	26.5	28	29.5	31	32.5	34	35.5	37

有效行程 Stroke	1650	1750	1850	1950	2050	2150	2250	2350	2450	2550	2650	2750	2850	2950	3050
L	2320	2420	2520	2620	2720	2820	2920	3020	3120	3220	3320	3420	3520	3620	3720
KG	38.5	40	41.5	43	44.5	46	47.5	49	50.5	52	53.5	55	56.5	58	59.5

LU 电机外置左上 Motor external upper left

单位:Unit: mm

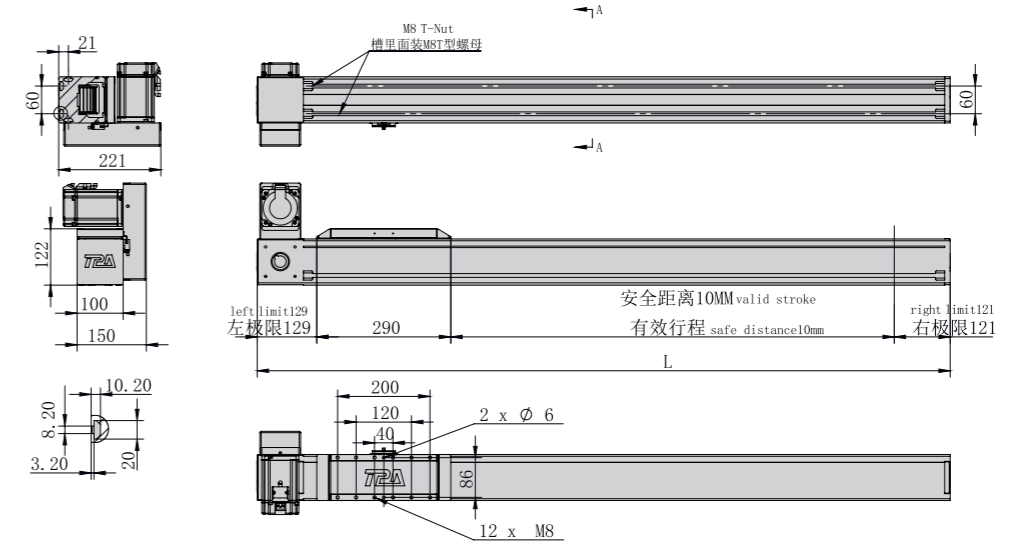

*不含电机和安装板重量 *Excluding motor and mounting plate weight

有效行程 Stroke	150	250	350	450	550	650	750	850	950	1050	1150	1250	1350	1450	1550
L	700	800	900	1000	1100	1200	1300	1400	1500	1600	1700	1800	1900	2000	2100
KG	16	17.5	19	20.5	22	23.5	25	26.5	28	29.5	31	32.5	34	35.5	37

有效行程 Stroke	1650	1750	1850	1950	2050	2150	2250	2350	2450	2550	2650	2750	2850	2950	3050
L	2200	2300	2400	2500	2600	2700	2800	2900	3000	3100	3200	3300	3400	3500	3600
KG	38.5	40	41.5	43	44.5	46	47.5	49	50.5	52	53.5	55	56.5	58	59.5



电机外置右下/电机外置右上
Motor external lower right / Motor external upper right

RP 电机外置右下 Motor external lower right

单位:Unit: mm

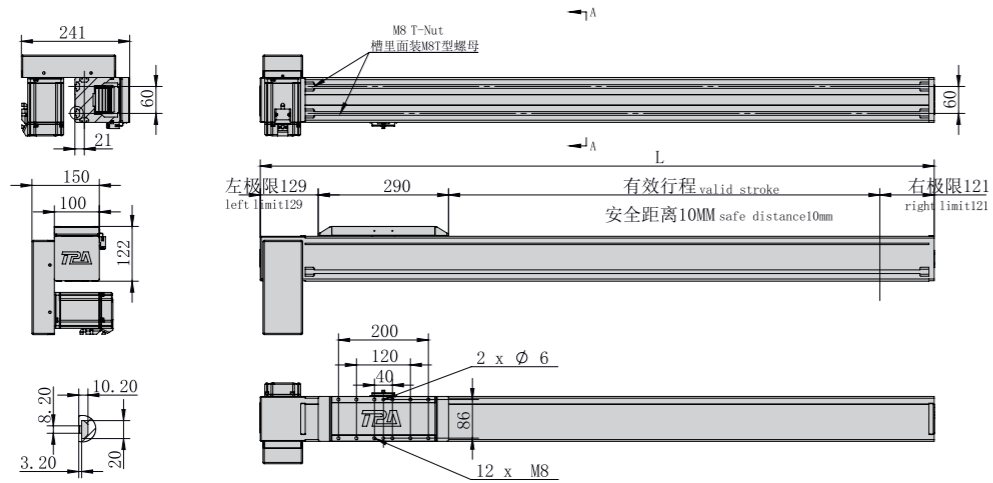

*不含电机和安装板重量 *Excluding motor and mounting plate weight

有效行程 Stroke	150	250	350	450	550	650	750	850	950	1050	1150	1250	1350	1450	1550
L	700	800	900	1000	1100	1200	1300	1400	1500	1600	1700	1800	1900	2000	2100
KG	16	17.5	19	20.5	22	23.5	25	26.5	28	29.5	31	32.5	34	35.5	37

有效行程 Stroke	1650	1750	1850	1950	2050	2150	2250	2350	2450	2550	2650	2750	2850	2950	3050
L	2200	2300	2400	2500	2600	2700	2800	2900	3000	3100	3200	3300	3400	3500	3600
KG	38.5	40	41.5	43	44.5	46	47.5	49	50.5	52	53.5	55	56.5	58	59.5

RU 电机外置右上 Motor external upper right

单位:Unit: mm

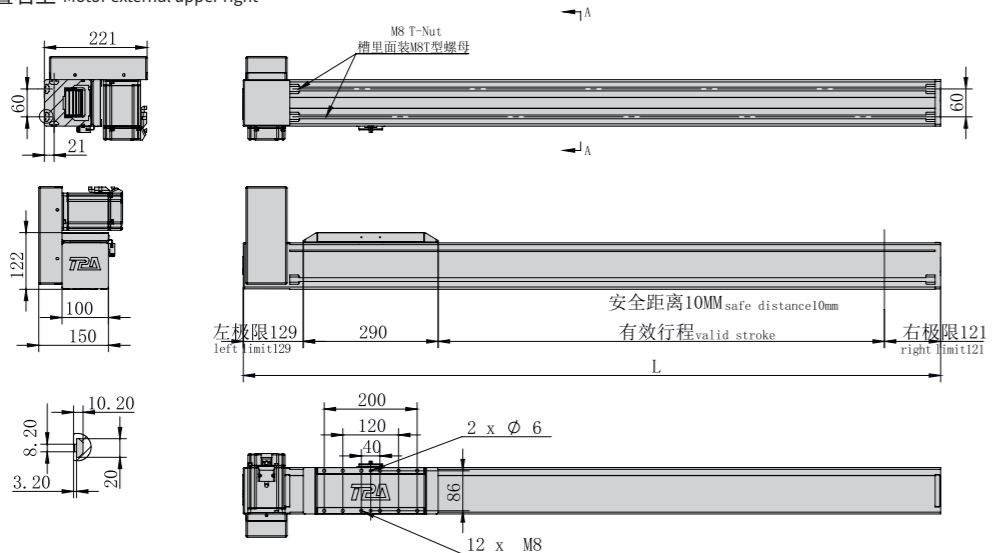

*不含电机和安装板重量 *Excluding motor and mounting plate weight

有效行程 Stroke	150	250	350	450	550	650	750	850	950	1050	1150	1250	1350	1450	1550
L	700	800	900	1000	1100	1200	1300	1400	1500	1600	1700	1800	1900	2000	2100
KG	16	17.5	19	20.5	22	23.5	25	26.5	28	29.5	31	32.5	34	35.5	37

有效行程 Stroke	1650	1750	1850	1950	2050	2150	2250	2350	2450	2550	2650	2750	2850	2950	3050
L	2200	2300	2400	2500	2600	2700	2800	2900	3000	3100	3200	3300	3400	3500	3600
KG	38.5	40	41.5	43	44.5	46	47.5	49	50.5	52	53.5	55	56.5	58	59.5

MEMO

ONB

OCB

参考资料
Reference
data

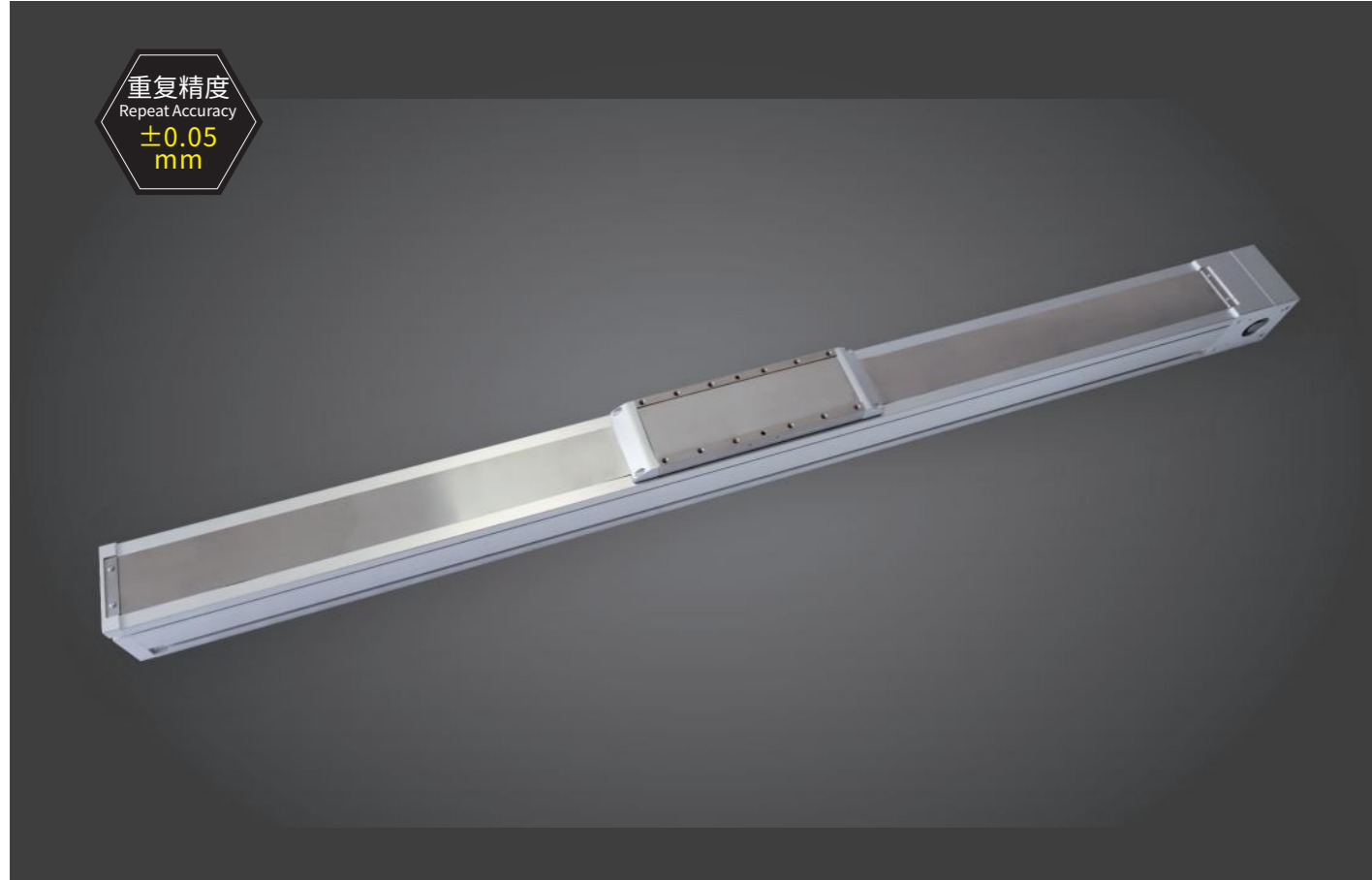

重复精度
Repeat Accuracy
±0.05 mm

此图仅供参考, 出货规格详见尺寸图面
This picture for reference only, specs details according with the drawing.

- 最大行程 Max Stroke: 4050mm
- 最高速度 Max Speed: 5000mm/s
- 马达容量 Motor Output: 750W
- 皮带宽度 Belt Width: 50mm
- 直线滑轨 Linear Guide: 30X26-1支

型号表达方式 Ordering method

TPA-OCB-120-224-L4050-MR-Y-P75B-N3-F

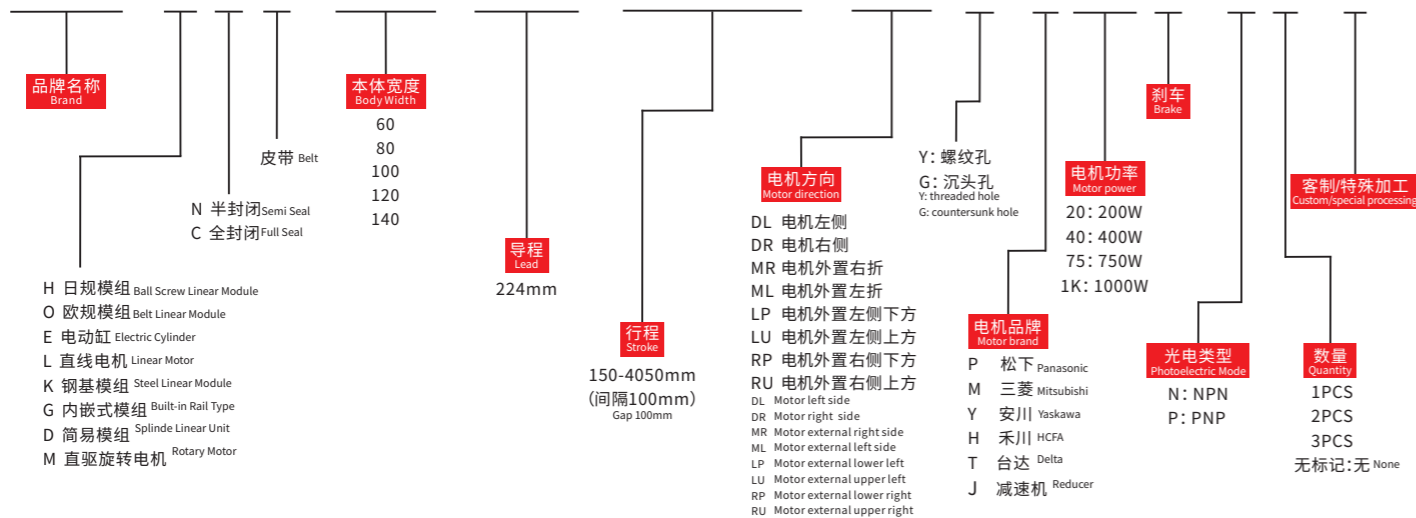

产品性能参数如下 Product performance parameters are as follows

规格 Spec	重复定位精度 (mm) Repeated positioning accuracy (mm)	±0.05		
	马达转速 (rpm/min) Rated Speed (rpm/min)	10:1	15:1	20:1
	最高速度 (mm/s) Maximum speed (mm/s)	1120	750	560
	最大可搬重量 Maximum Payload	水平使用 (kg) Horizontal (kg)	100	150
垂直使用 (kg) Vertical (kg) ^{※2}		20	40	60
部品 Parts	导程 (mm) lead (mm)	224		
	定格推力 (N) Rated thrust (N)	900		
	标准行程 (mm) Stroke pitch (mm) ^{※3}	150~4050mm/100 间隔 100 mm Pitch		
	AC伺服马达容量 (W) AC servo motor output (w)	750		
	皮带宽度 (mm) Belt Width(mm)	50		
原 点 感 应 器 Home sensor	外挂 Outside	672(NPN)		
	高刚性直线滑轨 (mm) High rigidity linear guide(mm)	30X26		

※1 马达加速设定0.4秒。※1 Acceleration and deceleration value is set 0.4 second.
 ※2 垂直使用时, 若皮带断裂, 承载物会有掉落危险, 请注意。
 ※2 Notice, if the belt breaks, the moving parts will fall when the application is vertical.
 ※3 滑台未安装减速机时, 导程为110。※3 Lead is 110mm without gearbox.

速度-荷重曲线图 Acceleration-payload relationship

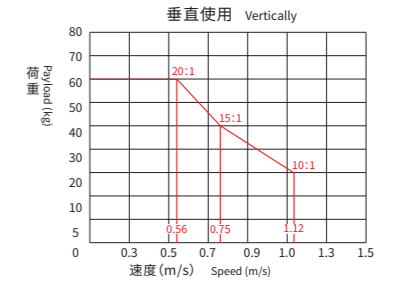
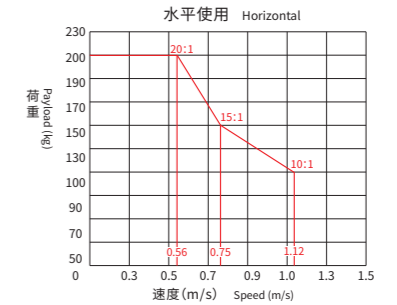

容许负载力矩表 N.m Allowable overhang

各行程M5后装螺帽数量 M5 nuts Qty.(by stroke)	
有效行程 Stroke	数量 Quantity
100~500	4
600~1000	6
1100~1500	8

※滑台标准固定方式为下锁式, 使用M5后装螺帽固定。
 ※Standard mounting method is fix from the bottom, using the M5 bolt and nut.

安装示意图 Installation diagram

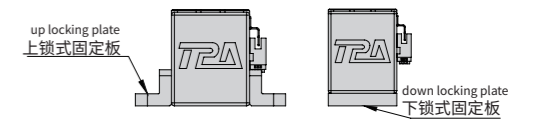

※上锁式固定板非标准品, 若有需求请另外追加选购。
 ※Top fixing plate is optional.

容许负载力矩表 N.m Allowable overhang

水平安装 Horizontal installation	(单位Unit:mm)		
	A	B	C
10:1	10kg	618	95
	20kg	418	45
	100kg	257	25
15:1	25kg	570	185
	35kg	335	85
	150kg	238	52
20:1	28kg	304	130
	40kg	209	80
	200kg	166	60

静态容许负载惯量 Static loading moment

(单位Unit:N.m)	
MY	1700
MP	1700
MR	500

*力矩表所表示的数据, 代表重心。
 The torque value in the chart indicate the center of gravity.
 *符合型录规范的正常试用下, 保证寿命为10000公里。
 Operation life is 10,000km when the product is using under the specified conditions.
 *倒吊使用无法套用标准规范, 如有需求请咨询我司业务。
 The standard specification cannot be applied to the use of inverted crane. Please consult our business if necessary.



电机外置左侧/电机外置右侧
Motor external left side / Motor external right side

ML 电机外置左侧 Motor external left side

单位:Unit: mm

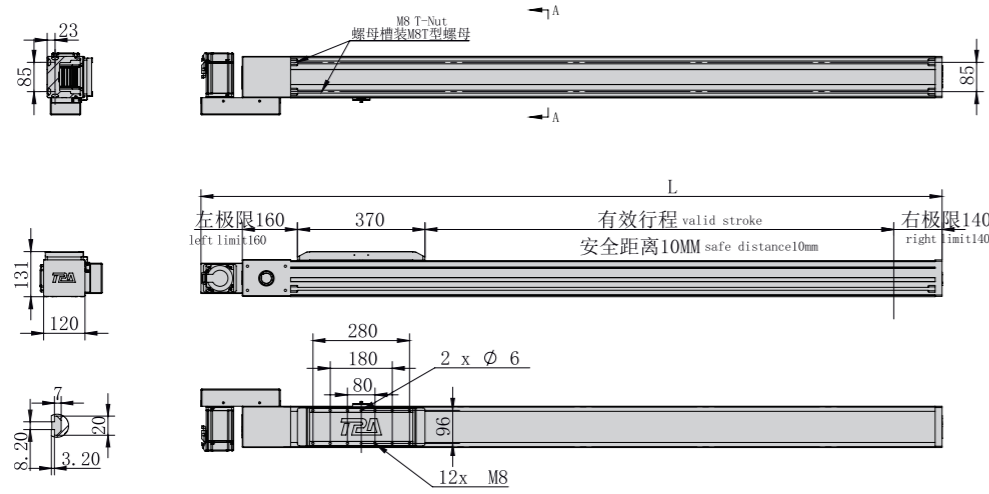

*不含电机和安装板重量 *Excluding motor and mounting plate weight

有效行程 Stroke	150	250	350	450	550	650	750	850	950	1050	1150	1250	1350	1450	1550	1650	1750	1850	1950	2050
L	950	1050	1150	1250	1350	1450	1550	1650	1750	1850	1950	2050	2150	2250	2350	2450	2550	2650	2750	2850
KG	21.4	23	24.6	26.2	27.8	29.4	31	32.6	34.2	35.8	37.4	39	40.6	42.2	43.8	45.4	47	48.6	50.2	51.8

有效行程 Stroke	2150	2250	2350	2450	2550	2650	2750	2850	2950	3050	3150	3250	3350	3450	3550	3650	3750	3850	3950	4050
L	2950	3050	3150	3250	3350	3450	3550	3650	3750	3850	3950	4050	4150	4250	4350	4450	4550	4650	4750	4850
KG	53.4	55	56.6	58.2	59.8	61.4	63	64.6	66.2	67.8	69.4	71	72.6	74.2	75.8	77.4	79	80.6	82.2	83.8

电机外置左下/电机外置左上
Motor external lower left / Motor external upper left

LP 电机外置左下 Motor external lower left

单位:Unit: mm

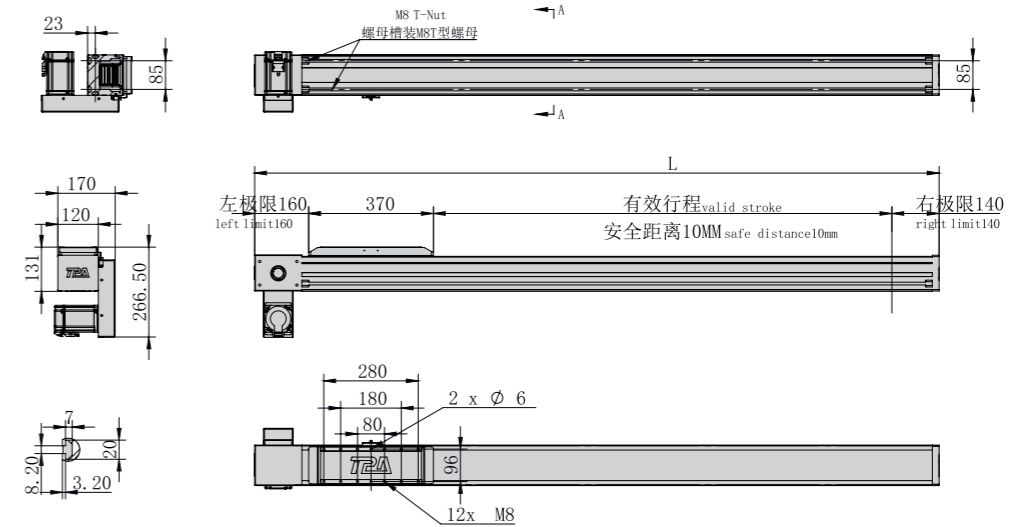

*不含电机和安装板重量 *Excluding motor and mounting plate weight

有效行程 Stroke	150	250	350	450	550	650	750	850	950	1050	1150	1250	1350	1450	1550	1650	1750	1850	1950	2050
L	830	930	1030	1130	1230	1330	1430	1530	1630	1730	1830	1930	2030	2130	2230	2330	2430	2530	2630	2730
KG	21.4	23	24.6	26.2	27.8	29.4	31	32.6	34.2	35.8	37.4	39	40.6	42.2	43.8	45.4	47	48.6	50.2	51.8

有效行程 Stroke	2150	2250	2350	2450	2550	2650	2750	2850	2950	3050	3150	3250	3350	3450	3550	3650	3750	3850	3950	4050
L	2830	2930	3030	3130	3230	3330	3430	3530	3630	3730	3830	3930	4030	4130	4230	4330	4430	4530	4630	4730
KG	53.4	55	56.6	58.2	59.8	61.4	63	64.6	66.2	67.8	69.4	71	72.6	74.2	75.8	77.4	79	80.6	82.2	83.8

MR 电机外置右侧 Motor external right side

单位:Unit: mm

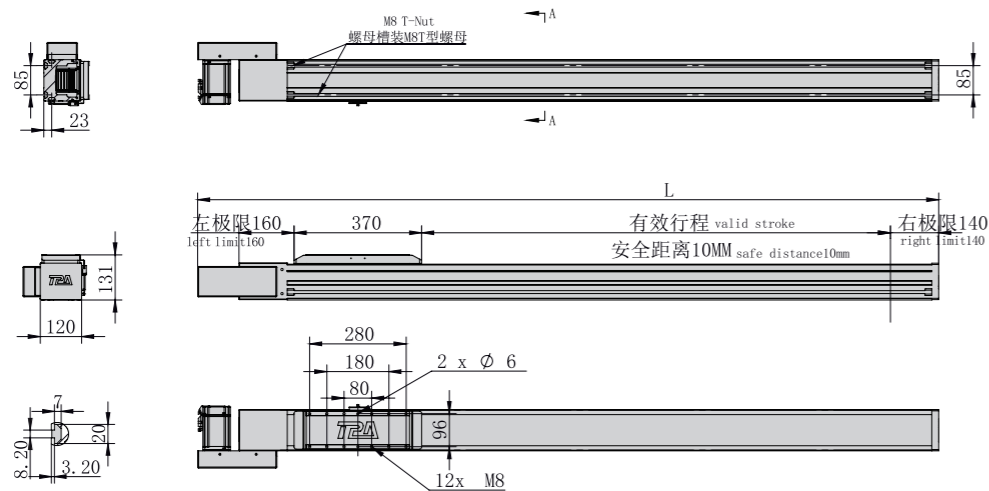

*不含电机和安装板重量 *Excluding motor and mounting plate weight

有效行程 Stroke	150	250	350	450	550	650	750	850	950	1050	1150	1250	1350	1450	1550	1650	1750	1850	1950	2050
L	950	1050	1150	1250	1350	1450	1550	1650	1750	1850	1950	2050	2150	2250	2350	2450	2550	2650	2750	2850
KG	21.4	23	24.6	26.2	27.8	29.4	31	32.6	34.2	35.8	37.4	39	40.6	42.2	43.8	45.4	47	48.6	50.2	51.8

有效行程 Stroke	2150	2250	2350	2450	2550	2650	2750	2850	2950	3050	3150	3250	3350	3450	3550	3650	3750	3850	3950	4050
L	2950	3050	3150	3250	3350	3450	3550	3650	3750	3850	3950	4050	4150	4250	4350	4450	4550	4650	4750	4850
KG	53.4	55	56.6	58.2	59.8	61.4	63	64.6	66.2	67.8	69.4	71	72.6	74.2	75.8	77.4	79	80.6	82.2	83.8

LU 电机外置左上 Motor external upper left

单位:Unit: mm

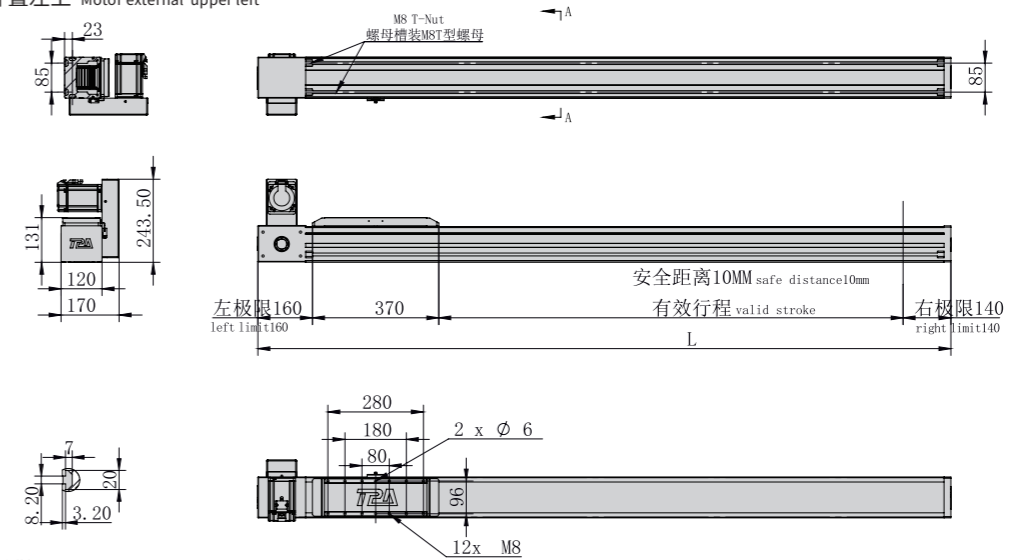

*不含电机和安装板重量 *Excluding motor and mounting plate weight

有效行程 Stroke	150	250	350	450	550	650	750	850	950	1050	1150	1250	1350	1450	1550	1650	1750	1850	1950	2050
L	830	930	1030	1130	1230	1330	1430	1530	1630	1730	1830	1930	2030	2130	2230	2330	2430	2530	2630	2730
KG	21.4	23	24.6	26.2	27.8	29.4	31	32.6	34.2	35.8	37.4	39	40.6	42.2	43.8	45.4	47	48.6	50.2	51.8

有效行程 Stroke	2150	2250	2350	2450	2550	2650	2750	2850	2950	3050	3150	3250	3350	3450	3550	3650	3750	3850	3950	4050
L	2830	2930	3030	3130	3230	3330	3430	3530	3630	3730	3830	3930	4030	4130	4230	4330	4430	4530	4630	4730
KG	53.4	55	56.6	58.2	59.8	61.4	63	64.6	66.2	67.8	69.4	71	72.6	74.2	75.8	77.4	79	80.6	82.2	83.8



电机外置右下/电机外置右上
Motor external lower right / Motor external upper right

RP 电机外置右下 Motor external lower right

单位:Unit: mm

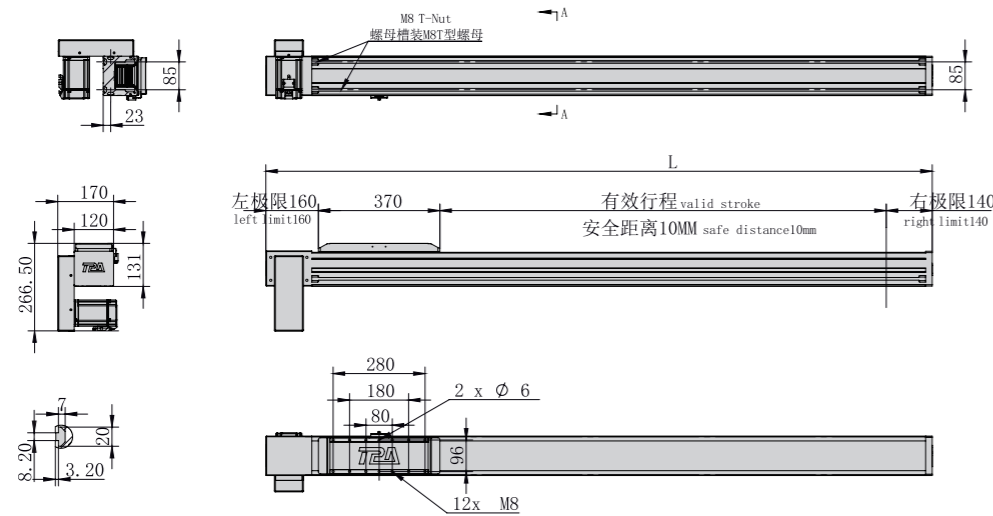

*不含电机和安装板重量 *Excluding motor and mounting plate weight

有效行程 Stroke	150	250	350	450	550	650	750	850	950	1050	1150	1250	1350	1450	1550	1650	1750	1850	1950	2050
L	830	930	1030	1130	1230	1330	1430	1530	1630	1730	1830	1930	2030	2130	2230	2330	2430	2530	2630	2730
KG	21.4	23	24.6	26.2	27.8	29.4	31	32.6	34.2	35.8	37.4	39	40.6	42.2	43.8	45.4	47	48.6	50.2	51.8

有效行程 Stroke	2150	2250	2350	2450	2550	2650	2750	2850	2950	3050	3150	3250	3350	3450	3550	3650	3750	3850	3950	4050
L	2830	2930	3030	3130	3230	3330	3430	3530	3630	3730	3830	3930	4030	4130	4230	4330	4430	4530	4630	4730
KG	53.4	55	56.6	58.2	59.8	61.4	63	64.6	66.2	67.8	69.4	71	72.6	74.2	75.8	77.4	79	80.6	82.2	83.8

RU 电机外置右上 Motor external upper right

单位:Unit: mm

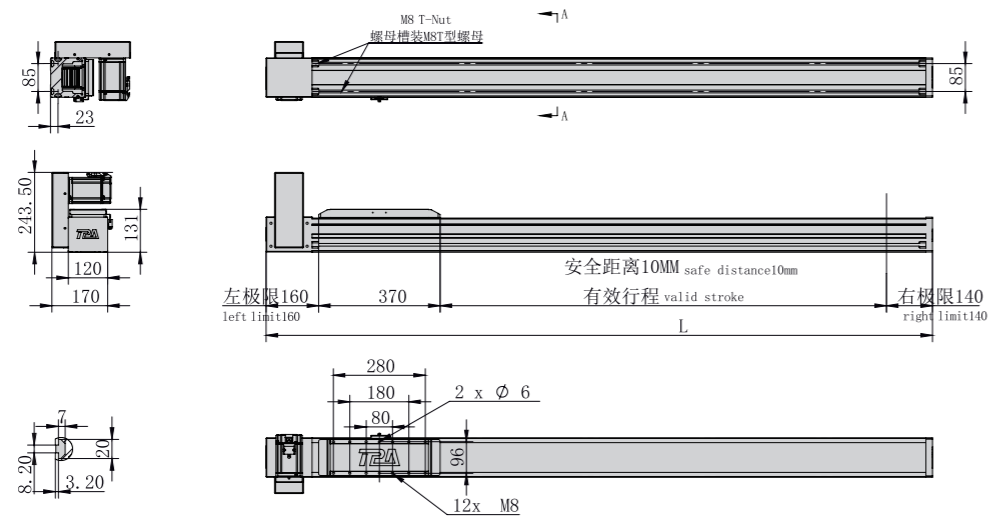

*不含电机和安装板重量 *Excluding motor and mounting plate weight

有效行程 Stroke	150	250	350	450	550	650	750	850	950	1050	1150	1250	1350	1450	1550	1650	1750	1850	1950	2050
L	830	930	1030	1130	1230	1330	1430	1530	1630	1730	1830	1930	2030	2130	2230	2330	2430	2530	2630	2730
KG	21.4	23	24.6	26.2	27.8	29.4	31	32.6	34.2	35.8	37.4	39	40.6	42.2	43.8	45.4	47	48.6	50.2	51.8

有效行程 Stroke	2150	2250	2350	2450	2550	2650	2750	2850	2950	3050	3150	3250	3350	3450	3550	3650	3750	3850	3950	4050
L	2830	2930	3030	3130	3230	3330	3430	3530	3630	3730	3830	3930	4030	4130	4230	4330	4430	4530	4630	4730
KG	53.4	55	56.6	58.2	59.8	61.4	63	64.6	66.2	67.8	69.4	71	72.6	74.2	75.8	77.4	79	80.6	82.2	83.8

MEMO

ONB

OCB

参考资料
Reference
data

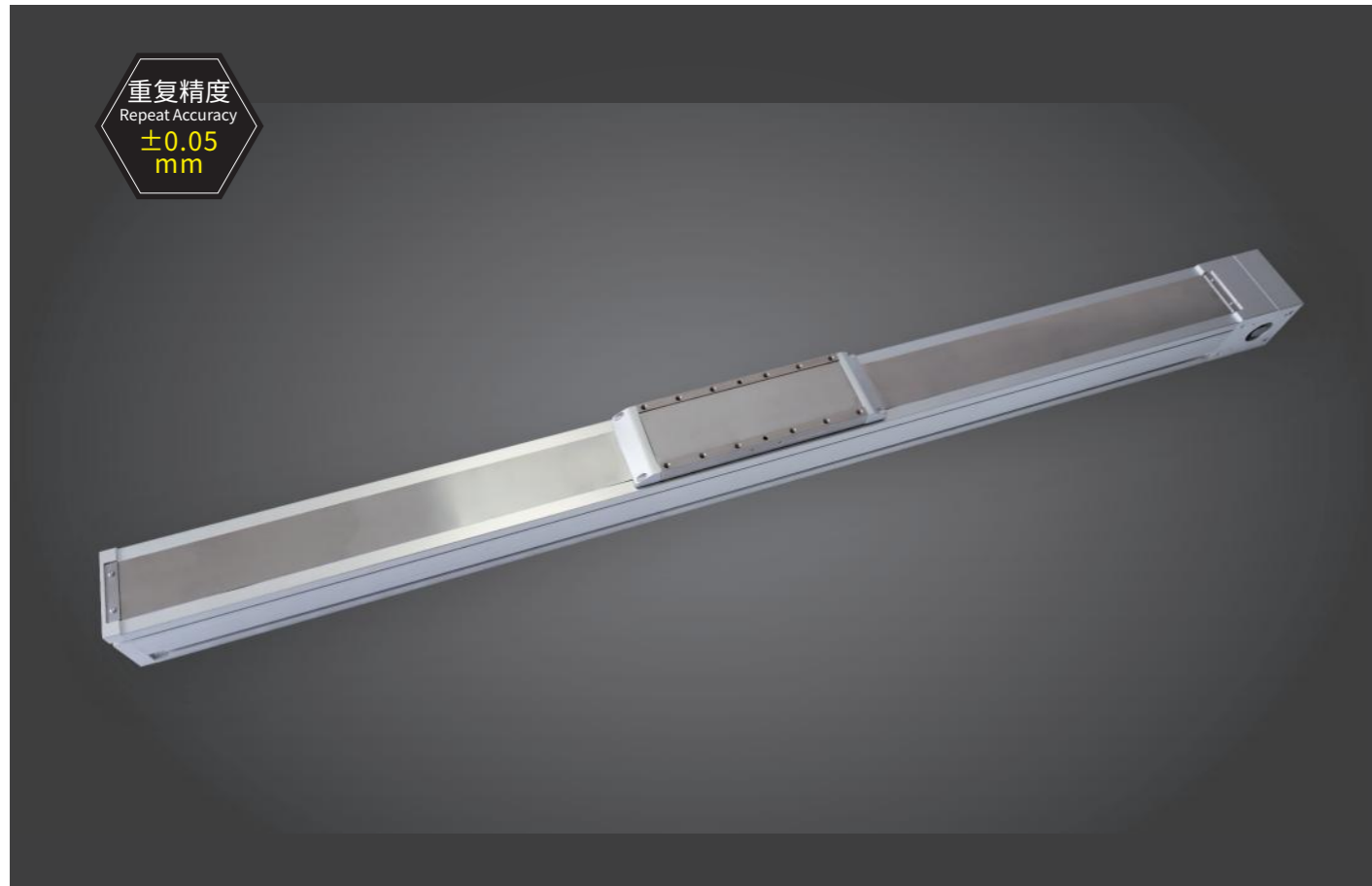

重复精度
Repeat Accuracy
±0.05 mm

此图仅供参考, 出货规格详见尺寸图面
This picture for reference only, specs details according with the drawing.

最大行程
Max Stroke **5050mm**

最高速度
Max Speed **5000mm/s**

马达容量
Motor Output **750W**

皮带宽度
Belt Width **60mm**

直线滑轨
Linear Guide **35X29-1支**

型号表达方式 Ordering method

TPA-OCB-140-256-L5050-MR-Y-J75B-N3-F

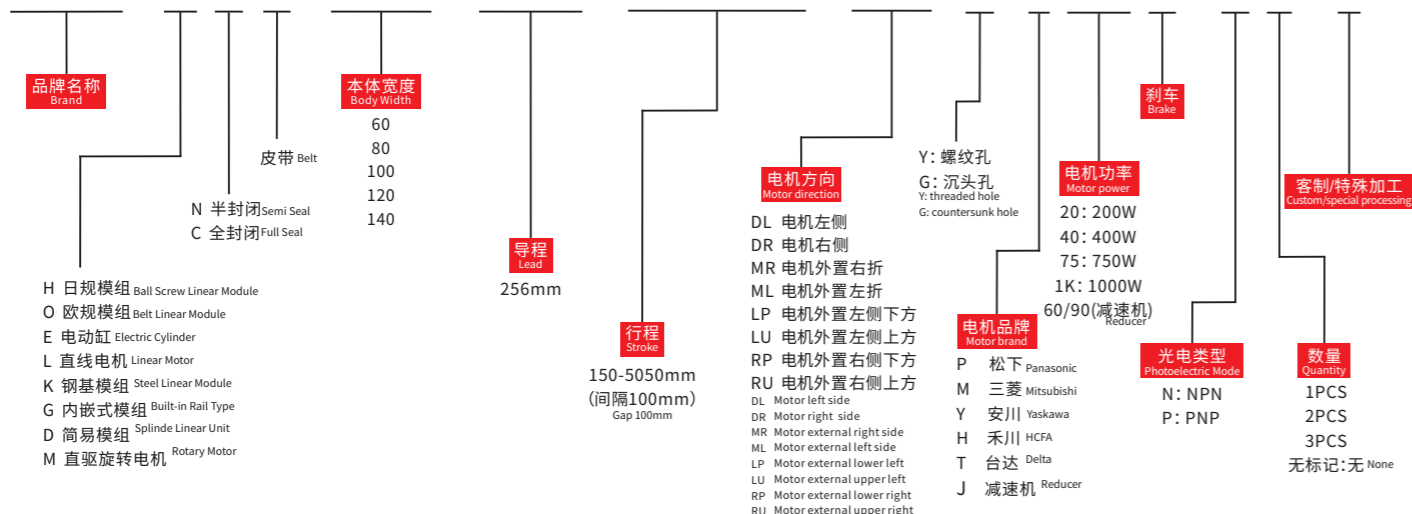

产品性能参数如下 Product performance parameters are as follows

规格 Spec	重复定位精度 (mm) Repeated positioning accuracy (mm)	±0.05		
	马达转速 (rpm) Rated Speed (rpm/min)	10:1	15:1	20:1
	最高速度 (mm/s) Maximum speed (mm/s)	700	470	350
	最大可搬重量 Maximum Payload	水平使用 (kg) Horizontal (kg)	100	160
垂直使用 (kg) Vertical (kg) ^{**2}		35	50	80
部品 Parts	导程 (mm) lead (mm)	256		
	定格推力 (N) Rated thrust (N)	1200		
	标准行程 (mm) Stroke pitch (mm) ^{**3}	150~5050mm/100 间隔 100 mm Pitch		
	AC伺服马达容量 (W) AC servo motor output (w)	750		
	皮带宽度 (mm) Belt Width(mm)	60		
原传感器 Home sensor	外挂 Outside	672(NPN)		
	高刚性直线滑轨 (mm) High rigidity linear guide(mm)	35X29		

^{**1} 马达加速设定0.4秒。 ^{**1} Acceleration and deceleration value is set 0.4 second.
^{**2} 垂直使用时, 若皮带断裂, 承载物会有掉落之危险, 请注意。
^{**2} Notice, if the belt breaks, the moving parts will fall when the application is vertical.
^{**3} 滑台未安装减速机时, 导程为110。 ^{**3} Lead is 110mm without gearbox.

容许负载力矩表 N.m Allowable overhang

各行程M5后装螺帽数量 M5 nuts Qty.(by stroke)			
有效行程 Stroke	数量 Quantity	有效行程 Stroke	数量 Quantity
100~500	4	2600~3000	14
600~1000	6	3100~3500	16
1100~1500	8	3600~4000	18
1600~2000	10	4100~4500	20
2100~2500	12	4600~5050	22

^{**}滑台标准固定方式为下锁式, 使用M5后装螺帽固定。
^{**}Standard mounting method is fix from the bottom, using the M5 bolt and nut.

容许负载力矩表 N.m Allowable overhang

速度比	水平安装 Horizontal installation			侧面安装 Side mounting			垂直安装 Vertical installation				
	A	B	C	A	B	C	A	B	C		
10:1	10kg	618	71	95	10kg	618	71	95	3kg	900	900
	20kg	418	31	45	20kg	418	31	45	6kg	450	450
	100kg	257	12	25	100kg	257	12	25	35kg	300	300
15:1	25kg	570	138	185	25kg	570	138	185	5kg	900	900
	35kg	335	67	85	35kg	335	67	85	10kg	450	450
	160kg	238	40	52	160kg	238	40	52	50kg	300	300
20:1	28kg	304	114	130	28kg	304	114	130	6kg	900	900
	40kg	209	67	80	40kg	209	67	80	12kg	450	450
	220kg	166	52	60	200kg	166	52	60	80kg	300	300

速度-荷重曲线图 Acceleration-payload relationship

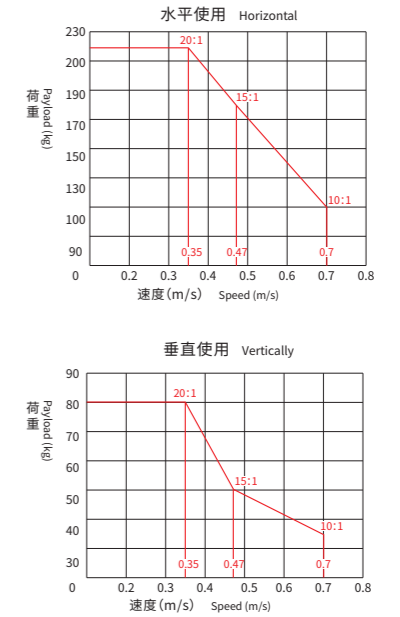

安装示意图 Installation diagram

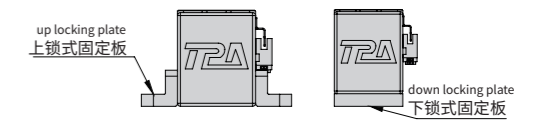

^{**}上锁式固定板非标准品, 若有需求请另外追加选购。
^{**}Top fixing plate is optional.

静态容许负载惯量 Static loading moment

负载类型	静态容许负载惯量 (N.m)
MY	2100
MP	2100
MR	800

*力矩表所表示的数据, 代表重心。
The torque value in the chart indicate the center of gravity.
*符合型录规范的正常试用下, 保证寿命为10000公里。
Operation life is 10,000km when the product is using under the specified conditions.
*倒吊使用无法套用标准规范, 如有需求请咨询我司业务。
The standard specification cannot be applied to the use of inverted crane. Please consult our business if necessary.



电机外置左侧/电机外置右侧
Motor external left side / Motor external right side

ML 电机外置左侧 Motor external left side

单位:Unit: mm

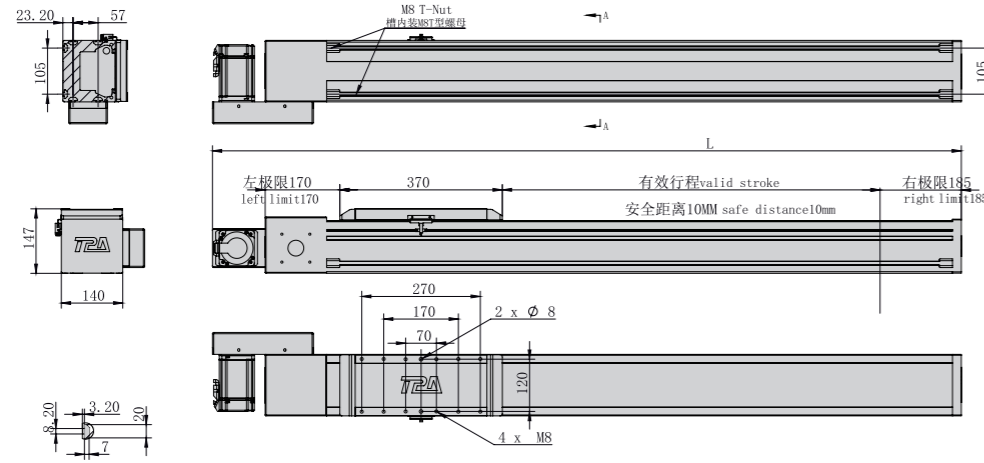

*不含电机和安装板重量 *Excluding motor and mounting plate weight

有效行程 Stroke	150	250	350	450	550	650	750	850	950	1050	1150	1250	1350	1450	1550	1650	1750	1850	1950	2050	2150	2250	2350	2450	2550
L	1005	1105	1205	1305	1405	1505	1605	1705	1805	1905	2005	2105	2205	2305	2405	2505	2605	2705	2805	2905	3005	3105	3205	3305	3405
KG	28.1	30.3	32.5	34.7	36.9	39.1	41.3	43.5	45.7	47.9	50.1	52.3	54.5	56.7	58.9	61.1	63.3	65.5	67.7	69.9	72.1	74.3	76.5	78.7	80.9

有效行程 Stroke	2650	2750	2850	2950	3050	3150	3250	3350	3450	3550	3650	3750	3850	3950	4050	4150	4250	4350	4450	4550	4650	4750	4850	4950	5050
L	3505	3605	3705	3805	3905	4005	4105	4205	4305	4405	4505	4605	4705	4805	4905	5005	5105	5205	5305	5405	5505	5605	5705	5805	5905
KG	83.1	85.3	87.5	89.7	91.9	94.1	96.3	98.5	100.7	102.9	105.1	107.3	109.5	111.7	113.9	116.1	118.3	120.5	122.7	124.9	127.1	129.3	131.5	133.7	135.9

电机外置左下/电机外置左上
Motor external lower left / Motor external upper left

LP 电机外置左下 Motor external lower left

单位:Unit: mm

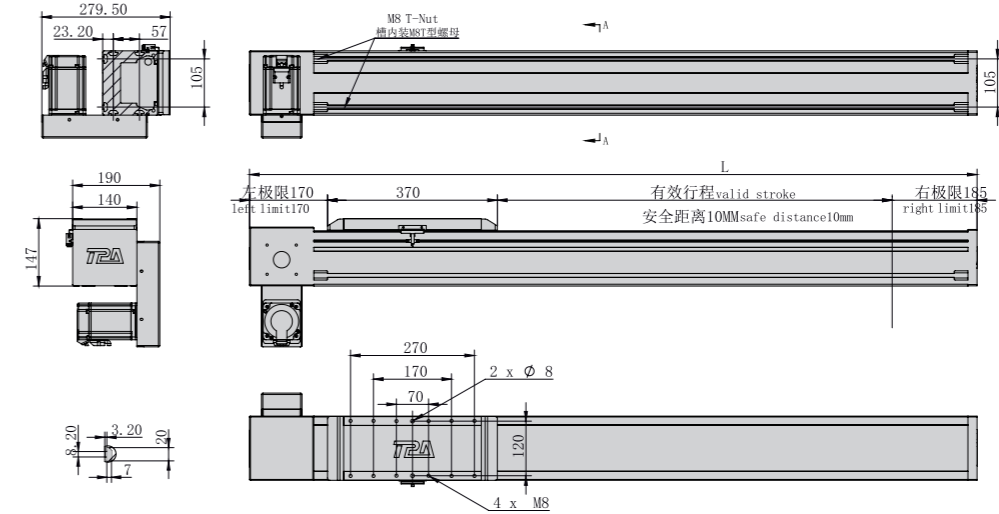

*不含电机和安装板重量 *Excluding motor and mounting plate weight

有效行程 Stroke	150	250	350	450	550	650	750	850	950	1050	1150	1250	1350	1450	1550	1650	1750	1850	1950	2050	2150	2250	2350	2450	2550
L	885	985	1085	1185	1285	1385	1485	1585	1685	1785	1885	1985	2085	2185	2285	2385	2485	2585	2685	2785	2885	2985	3085	3185	3285
KG	28.1	30.3	32.5	34.7	36.9	39.1	41.3	43.5	45.7	47.9	50.1	52.3	54.5	56.7	58.9	61.1	63.3	65.5	67.7	69.9	72.1	74.3	76.5	78.7	80.9

有效行程 Stroke	2650	2750	2850	2950	3050	3150	3250	3350	3450	3550	3650	3750	3850	3950	4050	4150	4250	4350	4450	4550	4650	4750	4850	4950	5050
L	3385	3485	3585	3685	3785	3885	3985	4085	4185	4285	4385	4485	4585	4685	4785	4885	4985	5085	5185	5285	5385	5485	5585	5685	5785
KG	83.1	85.3	87.5	89.7	91.9	94.1	96.3	98.5	100.7	102.9	105.1	107.3	109.5	111.7	113.9	116.1	118.3	120.5	122.7	124.9	127.1	129.3	131.5	133.7	135.9

MR 电机外置右侧 Motor external right side

单位:Unit: mm

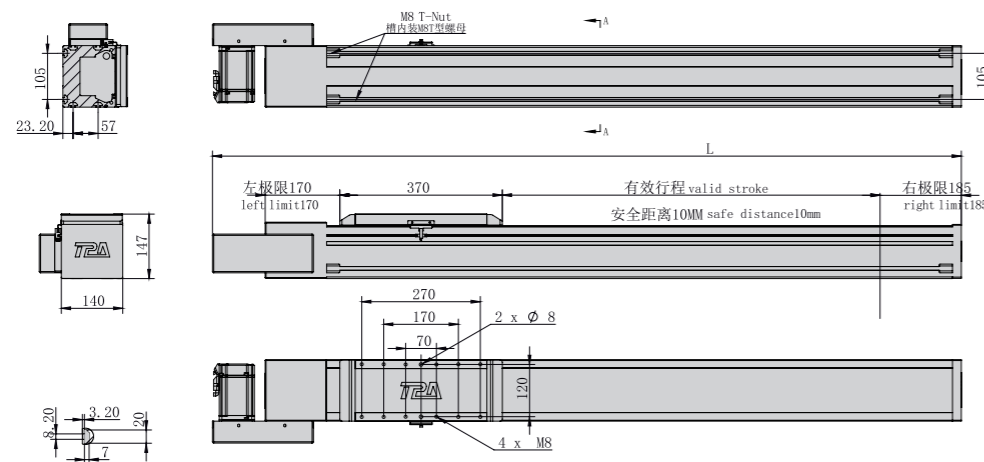

*不含电机和安装板重量 *Excluding motor and mounting plate weight

有效行程 Stroke	150	250	350	450	550	650	750	850	950	1050	1150	1250	1350	1450	1550	1650	1750	1850	1950	2050	2150	2250	2350	2450	2550
L	1005	1105	1205	1305	1405	1505	1605	1705	1805	1905	2005	2105	2205	2305	2405	2505	2605	2705	2805	2905	3005	3105	3205	3305	3405
KG	28.1	30.3	32.5	34.7	36.9	39.1	41.3	43.5	45.7	47.9	50.1	52.3	54.5	56.7	58.9	61.1	63.3	65.5	67.7	69.9	72.1	74.3	76.5	78.7	80.9

有效行程 Stroke	2650	2750	2850	2950	3050	3150	3250	3350	3450	3550	3650	3750	3850	3950	4050	4150	4250	4350	4450	4550	4650	4750	4850	4950	5050
L	3505	3605	3705	3805	3905	4005	4105	4205	4305	4405	4505	4605	4705	4805	4905	5005	5105	5205	5305	5405	5505	5605	5705	5805	5905
KG	83.1	85.3	87.5	89.7	91.9	94.1	96.3	98.5	100.7	102.9	105.1	107.3	109.5	111.7	113.9	116.1	118.3	120.5	122.7	124.9	127.1	129.3	131.5	133.7	135.9

LU 电机外置左上 Motor external upper left

单位:Unit: mm

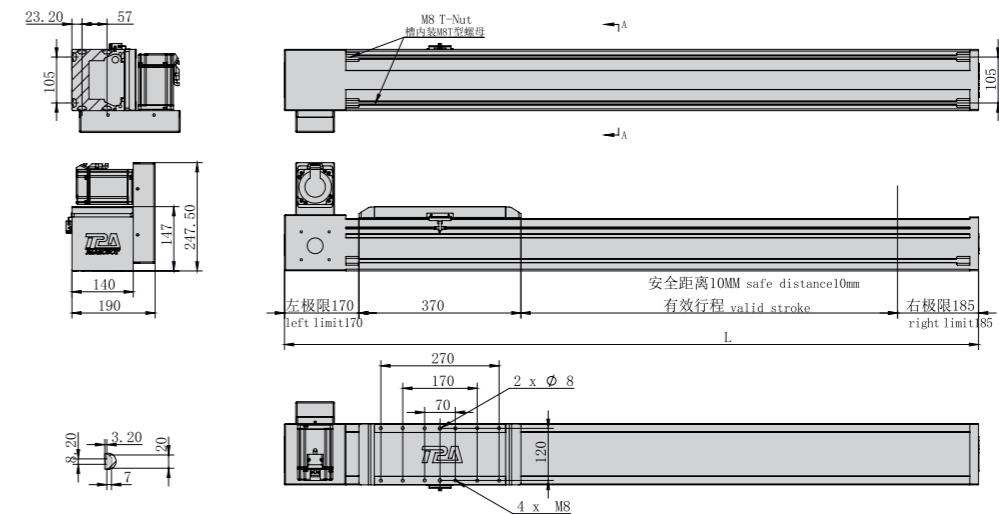

*不含电机和安装板重量 *Excluding motor and mounting plate weight

有效行程 Stroke	150	250	350	450	550	650	750	850	950	1050	1150	1250	1350	1450	1550	1650	1750	1850	1950	2050	2150	2250	2350	2450	2550
L	885	985	1085	1185	1285	1385	1485	1585	1685	1785	1885	1985	2085	2185	2285	2385	2485	2585	2685	2785	2885	2985	3085	3185	3285
KG	28.1	30.3	32.5	34.7	36.9	39.1	41.3	43.5	45.7	47.9	50.1	52.3	54.5	56.7	58.9	61.1	63.3	65.5	67.7	69.9	72.1	74.3	76.5	78.7	80.9

有效行程 Stroke	2650	2750	2850	2950	3050	3150	3250	3350	3450	3550	3650	3750	3850	3950	4050	4150	4250	4350	4450	4550	4650	4750	4850	4950	5050
L	3385	3485	3585	3685	3785	3885	3985	4085	4185	4285	4385	4485	4585	4685	4785	4885	4985	5085	5185	5285	5385	5485	5585	5685	5785
KG	83.1	85.3	87.5	89.7	91.9	94.1	96.3	98.5	100.7	102.9	105.1	107.3	109.5	111.7	113.9	116.1	118.3	120.5	122.7	124.9	127.1	129.3	131.5	133.7	135.9



电机外置右下/电机外置右上
Motor external lower right / Motor external upper right

RP 电机外置右下 Motor external lower right

单位:Unit: mm

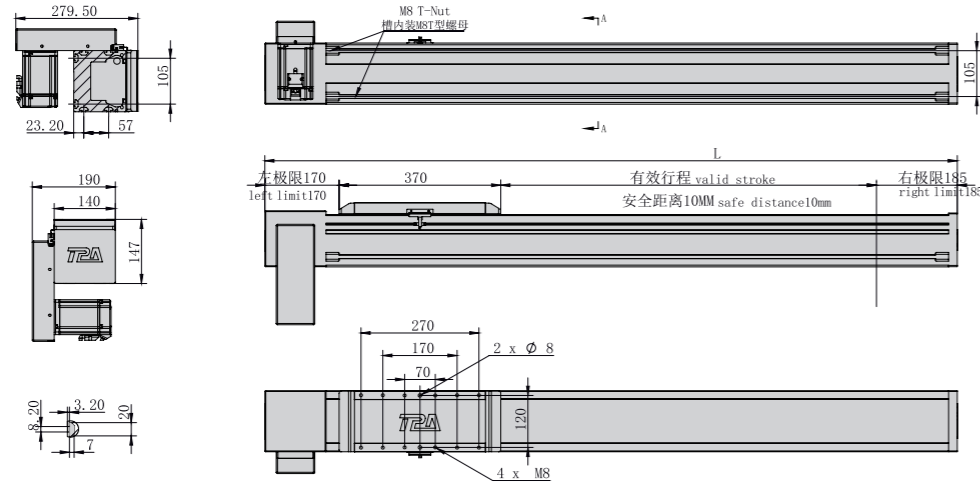

*不含电机和安装板重量 *Excluding motor and mounting plate weight

有效行程 Stroke	150	250	350	450	550	650	750	850	950	1050	1150	1250	1350	1450	1550	1650	1750	1850	1950	2050	2150	2250	2350	2450	2550
L	885	985	1085	1185	1285	1385	1485	1585	1685	1785	1885	1985	2085	2185	2285	2385	2485	2585	2685	2785	2885	2985	3085	3185	3285
KG	28.1	30.3	32.5	34.7	36.9	39.1	41.3	43.5	45.7	47.9	50.1	52.3	54.5	56.7	58.9	61.1	63.3	65.5	67.7	69.9	72.1	74.3	76.5	78.7	80.9

有效行程 Stroke	2650	2750	2850	2950	3050	3150	3250	3350	3450	3550	3650	3750	3850	3950	4050	4150	4250	4350	4450	4550	4650	4750	4850	4950	5050
L	3385	3485	3585	3685	3785	3885	3985	4085	4185	4285	4385	4485	4585	4685	4785	4885	4985	5085	5185	5285	5385	5485	5585	5685	5785
KG	83.1	85.3	87.5	89.7	91.9	94.1	96.3	98.5	100.7	102.9	105.1	107.3	109.5	111.7	113.9	116.1	118.3	120.5	122.7	124.9	127.1	129.3	131.5	133.7	135.9

RU 电机外置右上 Motor external upper right

单位:Unit: mm

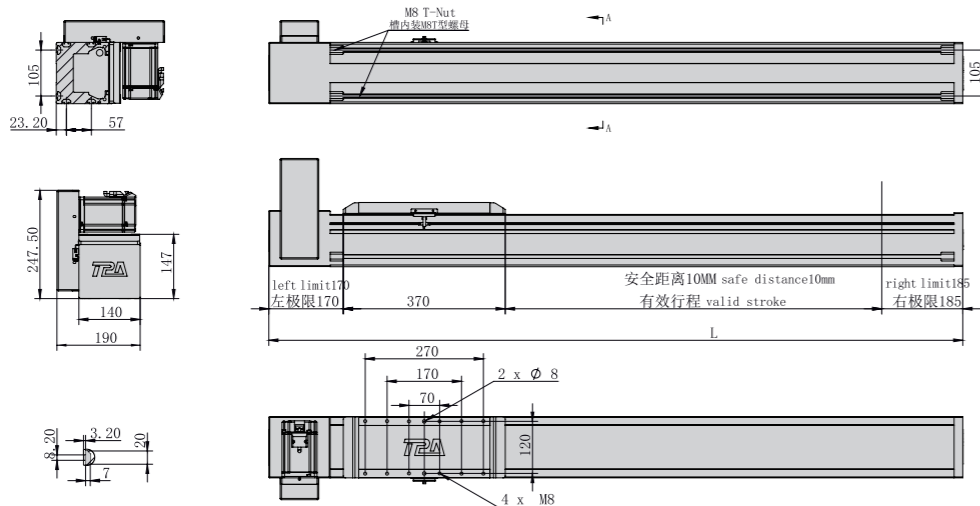

*不含电机和安装板重量 *Excluding motor and mounting plate weight

有效行程 Stroke	150	250	350	450	550	650	750	850	950	1050	1150	1250	1350	1450	1550	1650	1750	1850	1950	2050	2150	2250	2350	2450	2550
L	885	985	1085	1185	1285	1385	1485	1585	1685	1785	1885	1985	2085	2185	2285	2385	2485	2585	2685	2785	2885	2985	3085	3185	3285
KG	28.1	30.3	32.5	34.7	36.9	39.1	41.3	43.5	45.7	47.9	50.1	52.3	54.5	56.7	58.9	61.1	63.3	65.5	67.7	69.9	72.1	74.3	76.5	78.7	80.9

有效行程 Stroke	2650	2750	2850	2950	3050	3150	3250	3350	3450	3550	3650	3750	3850	3950	4050	4150	4250	4350	4450	4550	4650	4750	4850	4950	5050
L	3385	3485	3585	3685	3785	3885	3985	4085	4185	4285	4385	4485	4585	4685	4785	4885	4985	5085	5185	5285	5385	5485	5585	5685	5785
KG	83.1	85.3	87.5	89.7	91.9	94.1	96.3	98.5	100.7	102.9	105.1	107.3	109.5	111.7	113.9	116.1	118.3	120.5	122.7	124.9	127.1	129.3	131.5	133.7	135.9

MEMO

ONB

OCB

参考资料
Reference data

减速机

Reducer

当使用上有低转速的运转需求时,则可使用减速机来降低马达回转速度,且可避免低速时不稳定运转。此外减速机能提高输出扭矩,扭矩输出比例按马达输出乘减速比,选配时需要注意不能超出减速机额定扭矩。

When there is a need for low-speed operation, a reducer can be used to reduce the rotation speed of the motor, and unstable operation at low speed can be avoided. In addition, the reducer can improve the output torque, torque The output ratio is multiplied by the reduction ratio according to the motor output, and attention should be paid in the selection not to exceed the rated torque of the reducer.

减速范例:3000rpm的马达,搭配上减速比1:5的减速机,即3000/5=600rpm=10rps。

其速度为:(导程X转速)200X10=2000MM/S。

Example of deceleration: 3000rpm motor, matched with reducer with 1:5 upper reduction ratio, that is, 3000/5 = 600 rpm = 10 RPS.

Its speed is: (lead x rotation speed) 200x10 = 2000MM/s.

※减速机会有高温产生,如果接触将有可能造成人员烫伤。所以接触检查等情况时,请切断控制器电源,静待片刻并在确认温度下降之后再行接触。如果有任何减速机搭配上的疑问,请与本公司联系。

※There is high temperature in the deceleration opportunity, and it may cause scalding if contacted. Therefore, please cut off the power supply of the controller and be quiet during contact inspection. Wait for a moment and make contact after confirming the temperature drop. If you have any questions about the matching of reducers, please contact our company.



减速机参考资料 Reducer reference

厂牌Brand	型号Model
APEX	AB060
	AB090
TWPX	PS060
	PS090
CST	RH060
	RH092
PHT	DS060
GTC	GNP60

滑台选配时可应用需求,选择加装减速机,上列附表为减速机厂牌以及型号;而其详细规格尺寸信息,请参阅各厂牌规格。

When selecting the sliding table, you can choose to install the reducer according to the use requirements. The attached table above shows the brand and model of the reducer. And its detailed specification and size information, Please refer to the specifications of each brand.

伺服电机计算 Calculations about servo motors

A-电机扭矩计算公式: A- motor torque calculation formula:

$$T=9.5 \times P/N$$

T=电机扭矩 T = motor torque

P=电机功率 P = motor power

N=电机转速 N = motor speed

B-螺杆推力计算公式: B- Screw thrust calculation formula:

$$F=T_m \times 2 \times \pi \times \eta / S$$

F=螺杆推力 F=Ball screw thrust

T_m=入力扭矩 T_m=Force torque

η=马达正效率 η=Positive efficiency of motor

S=螺杆导程 S=Lead of ball screw

C-皮带轮导程计算公式: B- pulley lead calculation formula:

节圆直径PD=节距×齿数/π

Pitch diameter PD = pitch × number of teeth/π

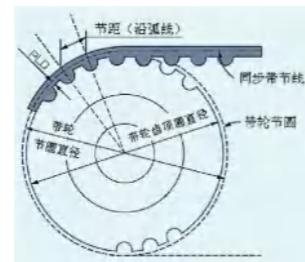

光电感应器接线说明

Wiring instructions of photoelectric sensor

直流4线式NPN输出 DC 4 wire NPN output

输入、输出电路

Input and output circuits

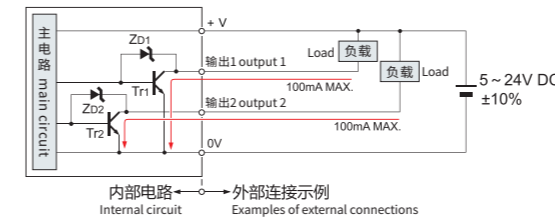

(注1): 对不使用的输出线, 请务必进行绝缘处理。

(Note 1): The unused output lines must be insulated.

符号... ZD1, ZD2: 电涌吸收齐纳二极管 Surge absorption zener diode
Symbol ... Tr1, Tr2: NPN输出晶体管 NPN output transistor

连接图

Connected graph

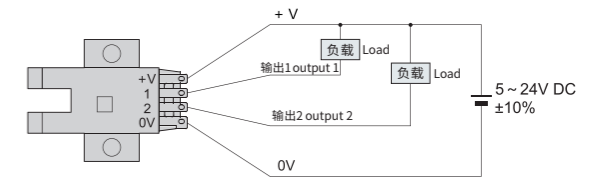

输出动作 Output action

	输出动作 Output action
输出1 output 1	遮光时ON Shading time ON
输出2 output 2	入光时ON Incident light ON

直流4线式PNP输出 DC 4 wire PNP output

输入、输出电路

Input and output circuits

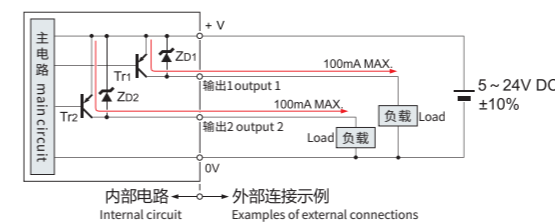

(注1): 对不使用的输出线, 请务必进行绝缘处理。

(Note 1): The unused output lines must be insulated.

符号... ZD1, ZD2: 电涌吸收齐纳二极管 Surge absorption zener diode
Symbol ... Tr1, Tr2: PNP输出晶体管 PNP output transistor

连接图

Connected graph

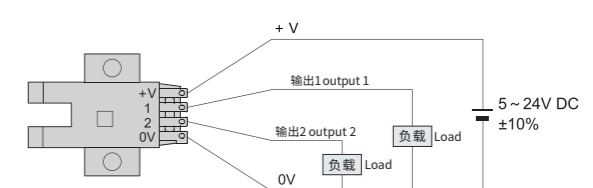

输出动作 Output action

	输出动作 Output action
输出1 output 1	遮光时ON Shading time ON
输出2 output 2	入光时ON Incident light ON

联轴器

Coupling

膜片联轴器安装注意说明 Notes on Installation of Diaphragm Coupling

锁付螺丝时有相对应之锁固力, 请参阅下表, 切勿过度施力或是未锁紧。
locking force when locking screws, please refer to the following table, do not overexert or unlocked.

在夹紧螺丝处于松动状态下, 请确认联轴器是否能沿轴向和旋转方向轻轻移动。如果不能平稳移动的话, 需重新调整两个轴的同轴度(马达锁固螺丝)。

When the clamping screw is loose, please confirm whether the coupling can move slightly in the axial and rotational directions. If you can't move smoothly, you need to readjust two. Concentricity of shaft (motor locking screw).

两个轴的同轴度若差异太大时, 将产生异音或是造成联轴器损坏。
If the concentricity of the 2 axes is too large, it will cause abnormal sound or cause damage to the coupling.



图1 Figure 1



图2 Figure 2

尺寸 Size	夹紧螺栓 Clamping bolt	锁紧扭矩 Locking torque (N·m)
20	M2.5	1.0~1.1
25	M2.5	1.0~1.1
30	M3	1.5~1.9
35	M4	3.4~4.1
40	M4	3.4~4.1
50	M5	7.0~8.5

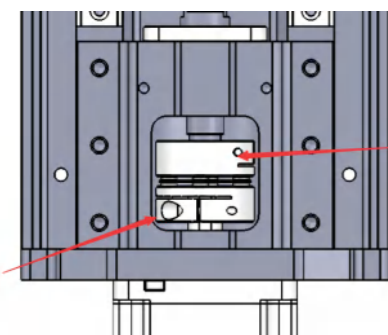
如图1、2先套上联轴器, 用手先转动, 检测同心度, 然后按照左图扭力锁紧螺丝。

As shown in figure 1、2, first put on the coupling, turn it by hand to detect the concentricity, and then lock the screw according to the torsional force in the left figure.

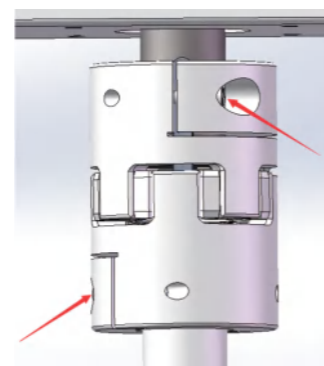
螺杆肩部与电机轴两轴组时, 需注意以下三种基本偏差, 说明图示如下: When assembling the screw and the motor shaft, the following three basic deviations should be paid attention to. The illustration is as follows:

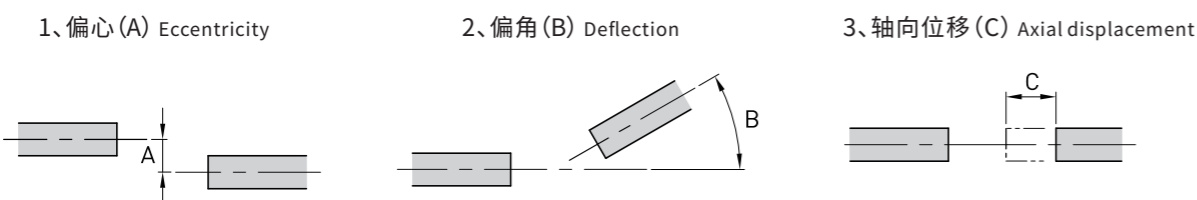

- 若自行购买马达安装, 安装联轴器时需特别注意下列几点:
- ◆ 锁付螺丝时相对应之锁固力, 请参阅右表, 切勿过度施力或是未锁紧。
 - ◆ 在夹紧螺丝虽处于松动状态下, 请确认联轴器是否能沿轴向和旋转方向轻轻移动。如果不能平稳移动的话, 需重新调整2个轴的同轴度(马达锁固螺丝)。
 - ◆ 2个轴的同轴度若差异太大时, 将产生异音或是造成联轴器损坏。

※调整2个轴的对心若有问题时, 请与本公司联络。

If you purchase the motor for installation by yourself, pay special attention to the following points when installing the coupling:

- ◆ Please refer to the right table for the corresponding locking force when locking screws. Do not apply excessive force or unlock them.
- ◆ Although the clamping screw is loose, please confirm whether the coupling can be light in the axial and rotational directions. Move lightly. If it can't move smoothly, it is necessary to readjust the concentricity of the two shafts (motor locking screws).
- ◆ If the concentricity of two shafts is too different, abnormal sound will be produced or the coupling will be damaged.

※If there is any problem in adjusting the alignment of two axes, please contact our company.

夹紧螺栓 The clamping bolt	锁紧扭矩 Locking torque (N·m)
M2.5	1.0~1.1
M2.5	1.0~1.1
M3	1.5~1.9
M4	3.4~4.1
M4	3.4~4.1
M5	7.0~8.5

联轴器参考资料 Reference data of coupling

型号 Model	容许扭矩 Permissible torque [N·m]	最大容许误差 Maximum permissible error			最高转速 Max speed [min ⁻¹]	扭转弹性 Torsional elasticity [N·m/rad]	轴向弹性 Axial elasticity [N·m/rad]	转动惯量 Moment of inertia [kg·m ²]	质量 Weight [kg]
		偏心 Eccentricity [mm]	偏角 Declination [°]	轴向位移 Axial displacement [mm]					
SFC-005SA2	0.5	0.02	0.5	±0.05	10000	500	140	0.25x10 ⁻⁶	0.007
SFC-010SA2	0.8	0.02	1	±0.1	10000	1400	140	0.58x10 ⁻⁶	0.011
SFC-020SA2	1.5	0.02	1	±0.15	10000	3700	64	2.36x10 ⁻⁶	0.025
SFC-030SA2	4	0.02	1	±0.2	10000	8000	64	4.00x10 ⁻⁶	0.033
								6.06x10 ⁻⁶	0.041
								8.12x10 ⁻⁶	0.049
SFC-035SA2	6	0.02	1	±0.25	10000	18000	112	18.43x10 ⁻⁶	0.084
SFC-040SA2	10	0.02	1	±0.3	10000	20000	80	16.42x10 ⁻⁶	0.076
								22.98x10 ⁻⁶	0.09
								29.53x10 ⁻⁶	0.105
SFC-050SA2	25	0.02	1	±0.4	10000	32000	48	54.88x10 ⁻⁶	0.156
								77.10x10 ⁻⁶	0.185
								99.33x10 ⁻⁶	0.214
SFC-060SA2	60	0.02	1	±0.45	10000	70000	76.4	143.7x10 ⁻⁶	0.279
								206.1x10 ⁻⁶	0.337
								268.5x10 ⁻⁶	0.396
SFC-080SA2	100	0.02	1	±0.55	10000	140000	128	709.3x10 ⁻⁶	0.727
SFC-090SA2	180	0.02	1	±0.65	10000	100000	108	1227x10 ⁻⁶	0.959
SFC-100SA2	250	0.02	1	±0.74	10000	120000	111	1858x10 ⁻⁶	1.181

※表中的转动惯量及质量是最大孔径时之值; 表中的扭转弹性常数数值仅为元件部分之值。

※The moment of inertia and mass in the table are the values at the maximum aperture; The values of torsional elasticity constants in the table are only the values of components.



同步带轮的安装方法

Installation of timing pulley and motor

1、下图为螺杆模组的转折形式：成品模组+同步轮+同步带+槽型光电（同步带形式模组安装方法一致，可参考本文）。

1、The following figure shows the turning form of screw module: finished module+synchronous wheel+synchronous belt+groove photoelectric (the installation method of synchronous belt module is the same, please refer to this article).



2、拆卸固定钣金的螺丝后，即可看到螺杆端同步轮我厂已安装好。只需要客户安装电机/减速机端的同步轮。

2、After removing the screws fixing the sheet metal, we can see that the screw end synchronous wheel has been installed in our factory. Only the customer needs to install the synchronous wheel at the motor/reducer end.



3、安装电机（一般电机包装内有螺丝提供），并锁紧固定电机的4颗螺丝（红色区域）之后拧松固定拉板的固定螺丝（蓝色和绿色区域）。

3、Install the motor (screws are provided in the general motor package), and after locking the four screws (red areas) that fix the motor, loosen the fixing screws (blue and green areas) that fix the pull plate.

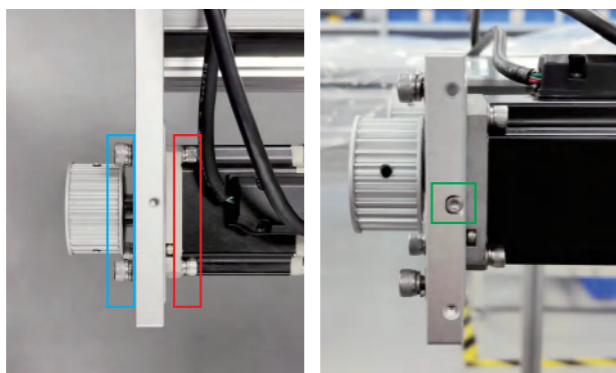

4、因拧松固定拉板的螺丝。电机端同步轮可左右来回活动。借助6MM六角扳手（不限于扳手）。

4、Loosen the screw fixing the pull plate. The synchronous wheel at the motor end can move back and forth left and right. With the help of a 6MM hex wrench (not limited to wrenches).

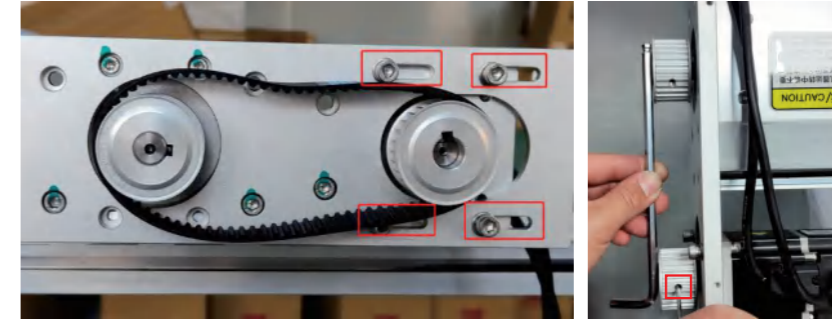

5、固定同步轮上紧固螺丝（一般情况下2个）。蓝色区域M3螺丝锁紧，红色区域螺丝会向右侧移动。蓝色区域张紧中，可用手感受同步带的张紧，也可使用专业设备测试张紧。最后在安装钣金折罩，固定螺丝即可。

5、Fastening screws on the synchronizing wheel (usually 2). The blue area M3 screw is locked, and the red area screw will move to the right. In the blue area, feel is available. When the timing belt is tensioned, you can also use professional equipment to test the tension. Finally, install the sheet metal folding cover and fix the screws.

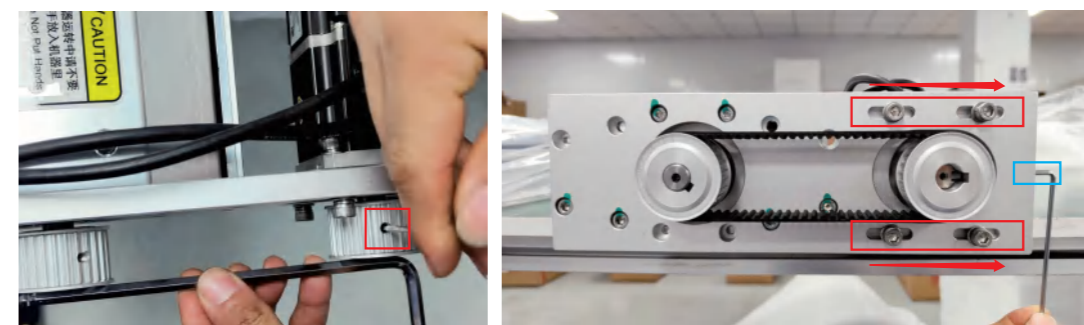



使用安全注意事项

Safety use and cautions

◆ 以下为几条建议以防产品使用过程中产生问题。

Here are a few Suggestions to prevent problems during product use.

为防止事故发生及安全维护, 请使用本公司产品前, 必须了解产品的特性和使用条件、安装说明。

In order to prevent accidents and safety maintenance, before you use the company's product, you must understand the characteristics of the products and use conditions, installation instructions.

请在选型的参数范围内使用本型号的产品, 不可超出参数范围使用, 否则会造成不可预知的危险。如果是特殊条件使用, 必须确认在可控安全性能之内, 方能使用, 对产品参数如有疑问, 在未使用之前, 可咨询本公司相关技术。

Please use the product of this model within the selected parameter range, and do not use it beyond the parameter range, otherwise it will cause unpredictable danger. If it is used under special conditions, it must be confirmed that it is within the controllable safety performance before it can be used. If you have any questions about the product parameters, you can consult the relevant technology of our company before you use it.

请勿私自拆卸本产品结构, 功能做分解及改造, 如因人造成的一切原因, 本公司不负责产品故障造成的损失。

Please do not disassemble the structure and function of this product without permission, and decompose and transform it. For all reasons caused by man-made, our company will not be responsible for the loss caused by product failure.

请注意: 当产品为垂直安装的时候, 请注意拆卸马达时, 滑座物件是否会自行下降, 建议拆卸的时候将滑座物件下降到最低端再拆卸。

Please note: When the product is installed vertically, please pay attention to whether the slide object will drop by itself when the motor is disassembled. It is

产品运行前, 先检查电缆线端子是否接触良好, 否则会导致电机发热发烫, 运行不畅。

Before running the product, check whether the cable terminals are in good contact or not, otherwise the motor will become hot and run poorly.

调试马达参数的时候需要考虑到惯性及加减速度等原因, 先手动控制, 来回点动, 防止调试不适当, 撞坏物件。不允许手及其它物体接触, 保持一定安全距离, 防止造成误伤。

When debugging the parameters of the motor, we need to consider the reasons of inertia, acceleration and deceleration. We should control the motor manually and move it back and forth to prevent the inappropriate debugging and damage the object. It is not allowed to contact hands and other objects to maintain a safe distance and prevent accidental injury.

当选用螺杆传动产品的时候, 如超出螺杆细长比参数, 可能会发生共振现象, 此时应降低移动速度。如选用皮带传动产品的时候, 如电机报警, 产品运行不动, 此时因加减减速机, 调节电机刚性, 加大扭矩, 从而平稳运行。

When the screw drive product is selected, if the slenderness ratio parameter of the screw exceeds, resonance may occur, so the moving speed should be reduced. Choose a belt. When the product is driven, such as the motor alarm, the product will not move. At this time, the reducer is added to adjust the rigidity of the motor

安装本产品时, 请务必确认所有的螺丝均已按要求锁紧, 否则产品运行时可能会发生危险。

When installing this product, please make sure that all screws are locked as required, otherwise the product may be in danger during operation.

请不要在接通电源的情况下进行产品拆装或零部件拆装, 否则可能发生触电、故障或其它危险。

Please do not disassemble the product or parts when the power is turned on, otherwise electric shock, malfunction or other dangers may occur.

禁止撕除警告标示, 或者警告标示被其它物品遮挡, 否则可能因为没有看到警告而导致事故发生。

It is forbidden to tear off the warning signs, or the warning signs are blocked by other objects, otherwise the accident may occur because you don't see the warning.

本注意事项无法完全涵盖所有的问题, 请务必详细了解产品及其使用说明, 并遵守相关安全守则, 做好必要保护措施, 以免造成产品损坏或导致人身安全问题。如有其它相关问题, 可咨询本公司。

This note can not cover all the problems. Please be sure to understand the product and its instructions in detail. comply with relevant safety codes, and take necessary protective measures to avoid product damage or personal safety problems. If you have any other related questions, you can consult us.



维护保养手册

一、日常检查项目

线性模组是一种常见的皮带传动机构,在实际操作中,被广泛应用到各种各样的设备中,因使用环境和用工况不同,需要及时检查和维护。

日常检查项目	
1. 检查部件表面是否有损伤,压痕和摩擦情况。	2. 检查皮带是否张紧,是否达到张力计参数标准。
3. 调试的时候因查阅同步带参数避免速度过快撞机。	4. 模组程序启动,人应离开模组安全距离,避免人身伤害。

二、周期维护项目

配件	维护方案	维护周期	具体操作
同步带	垂直使用情况下,皮带张紧力校核。	每半个月检查下皮带松弛。	把张力计对着皮带间距10MM处,手拨动皮带,皮带震动显示数值,是否达到出厂时的参数值,若不是,拧紧张紧机构。
线性滑轨	增加润滑脂(粘度:30-150cts)清理旧油污,注入新润滑脂。	每月一次或每行走100KM的距离。	用无尘布直接擦拭干净轨道表面及轨道珠槽,将新润滑脂直接注入油孔。

三、异常问题以及解决方法

线性模组异常情况	维修、排除方法
电源接入时产生异音	1. 调整伺服驱动器内参数“机械共振抑制”数值。 2. 调整伺服驱动器内参数“自动调谐”数值。
如联轴器,同步轮出现打滑	1. 检查同步轮,联轴器是否锁紧。 2. 检查同步轮,联轴器是否带键槽。 3. 同步轮和联轴器的轴是否匹配。
马达运转时滑台不顺畅	1. 检查刹车是否释放。 2. 将马达与线性模组分离,手推滑动座,判断问题点原因。 3. 检查联轴器固定螺丝是否松动。 4. 检查线性模组移动区域是否有异物掉落。
皮带模组运行出现定位精度不准	1. 检查皮带是否松弛,皮带出现跳齿。 2. 检查皮带导程输入数值是否正确。
如何服电机报警,显示过载	1. 检查刹车是否释放。 2. 检查联轴器固定螺丝是否松动。 3. 因加减速机,加大速比,增大扭矩,降低速度。

另本公司负责自身商品的故障维修,并不负责因产品故障引起的其他损失。

Maintenance manual

一、Daily inspection items

Linear module is a common belt transmission mechanism, which is widely used in all kinds of equipment in actual operation. It needs to be checked and maintained in time because of the different environment and working conditions.

Daily inspection items	
1. Check the surface of parts for damage, indentation and friction.	2. Check whether the belt is tensioned and meets the parameter standard of tensiometer.
3. When debugging, consult the timing belt parameters to avoid too fast collision.	4. When the module starts, people should leave the module at a safe distance to avoid personal injury.

二、Periodic maintenance project

Parts	Maintenance scheme	Maintenance cycle	Specific operation
Synchronous belt	Under vertical use, belt tension Check.	Check the belt slack every half month.	Point the tensiometer at the belt spacing of 10mm, and touch the belt by hand. The vibration of the belt shows whether the value reaches the factory parameter value. If not, screw the tensioning mechanism.
Linear slide rail	Add grease (viscosity: 30-150cts) Clean up old grease and inject new grease.	Once a month or every 100KM distance.	Clean the track surface and track bead groove directly with a dust-free cloth, and directly inject new grease into the oil hole.

三、Exceptions and solutions

Linear module abnormal situation	Maintenance and troubleshooting methods
Abnormal sound is produced when the power supply is connected.	1. Adjust the value of the servo drive parameter "mechanical resonance suppression". 2. Adjust the value of Auto tuning in the servo driver.
For example, the coupling and synchronous wheel slip.	1. Check whether the synchronizing wheel and coupling are locked. 2. Check whether the synchronizing wheel and coupling have keyways. 3. Whether the shafts of the synchronizing wheel and the coupling are matched.
The sliding table is not smooth when the motor is running.	1. Check the brake release. 2. Separate the motor from the linear module and push the sliding seat to determine the cause of the problem. 3. Check the coupling setting screws for loosening. 4. Check whether foreign objects have fallen from the moving area of the linear module.
The positioning accuracy of belt running is inaccurate.	1. Check whether the belt is slack, and the belt has tooth jumping. 2. Check whether the input value of belt lead is correct.
If the servo motor alarms, overload is displayed.	1. Check the brake release. 2. Check whether the coupling fixing screw is loose. 3. Increase the speed ratio, torque and speed by adding a reducer.

In addition, the company is responsible for the fault maintenance of its own goods, and is not responsible for other losses caused by product failure.



Linear Servo Actuator Demand Specification Survey

客户名称:			邮箱:				
电话:			:				
接洽人:			:				
使用需求	行程 (mm):		(mm/s):				
	负载 (kg):		mm				
	(s):		(s):				
	工件力矩 (mm)						
		A	B	C	A	B	C
组合形式	A系列	A1	A2	A3	A4	A: _____	
	G系列	G1	G2	G3	G4	G: _____	
	F系列	F1	F2	F3	F4	F: _____	
	P系列	P1	P2	P3	P4	P: _____	
Y	0-500	500-800	800-1200				
电机连接方式	X	M	MP	MR	LP	RP	DL
		MD	MU	ML	LU	RU	DR
	Y	M	MP	MR	LP	RP	DL
		MD	MU	ML	LU	RU	DR
Z	M	MP	MR	LP	RP	DL	
	MD	MU	ML	LU	RU	DR	
	M	MP	MR	LP	RP	DL	
	MD	MU	ML	LU	RU	DR	
:		:					
传感器位置	内置 <input type="checkbox"/> 外挂 <input type="checkbox"/>	NPN <input type="checkbox"/> PNP <input type="checkbox"/>		数目: _____ 个			
应用方式	取放物料 <input type="checkbox"/>		CCD检测 <input type="checkbox"/>	加工物件 <input type="checkbox"/>	涂胶 <input type="checkbox"/>		
	定点检测 <input type="checkbox"/>		位移检测 <input type="checkbox"/>	锁螺丝 <input type="checkbox"/>	其他: _____		
应用环境	无尘环境 <input type="checkbox"/>						
	一般环境 <input type="checkbox"/>						
	不要求 <input type="checkbox"/>	70~80db <input type="checkbox"/>	60~70db <input type="checkbox"/>	(分贝等级会影响单价)			
			指定厂牌:	()			
设备设计模式	量产机:		开发机:				
因组合形式较多, 实际细节请和设计部门详细讨论。							
备注:							

Customer name			Email				
Telephone			Address				
Contact person			Title				
Usage requirement	Stroke (mm)		maximum speed (mm/s)				
	Load (kg)		Repetition positioning accuracy (mm)				
	Residence time (s)		Acceleration and deceleration time(s)				
	Installation method						
	Load and Cantilever Length (mm)						
A		B	C	A	B	C	A
Combination form	A Series	A1	A2	A3	A4	A: _____	
	G Series	G1	G2	G3	G4	G: _____	
	F Series	F1	F2	F3	F4	F: _____	
	P Series	P1	P2	P3	P4	P: _____	
The Y-axis cantilever is too long. It is recommended to use auxiliary rails within the span of 0-500, auxiliary shafts for 500-800 and double drives for 800-1200.							
Motor connection mode	X axis	M	MP	MR	LP	RP	DL
		MD	MU	ML	LU	RU	DR
	Y axis	M	MP	MR	LP	RP	DL
		MD	MU	ML	LU	RU	DR
Z axis	M	MP	MR	LP	RP	DL	
	MD	MU	ML	LU	RU	DR	
single axis	M	MP	MR	LP	RP	DL	
multi axis	MD	MU	ML	LU	RU	DR	
Servo motor	Brand: _____		Model: _____				
Sensor position	Inside <input type="checkbox"/> Outside <input type="checkbox"/>	Type: NPN <input type="checkbox"/> PNP <input type="checkbox"/>		Quantity: _____ Pcs			
Application mode	Take and place materials		CCD detection	Machining material		Dispense <input type="checkbox"/> Handling <input type="checkbox"/>	
	Fixed-point detection		Displacement detection	Lock screw		Other: _____	
Application environment	Dust free environment <input type="checkbox"/>		Drive Method	Screw <input type="checkbox"/> Belt <input type="checkbox"/> Gear rack <input type="checkbox"/>			
	General environment <input type="checkbox"/>						
Module noise requirements	Does not require <input type="checkbox"/>		70~80db <input type="checkbox"/>	60~70db <input type="checkbox"/>	(decibel level will affect the unit price)		
Ball screw brand	Screw <input type="checkbox"/>		Designated brand:		(Ball screw brand will affect unit price)		
Equipment design mode	Mass production machine:		Development machine:				
As there are many combinations, please discuss the actual details with the design department in detail.							
Remarks:							
Customer name:	Signature:		Date:				

ONB

OCB

参考资料
Reference data